

Altitude au dessus de la mer
RPN = 373.60

Profil en long
Pente maximum
Rampe maximum

Situation des stations, bifurcations, plus longues voies d'évitement

Stations de block

d/p Renens

Distance de stat. à stat.

Kilométrage de la voie

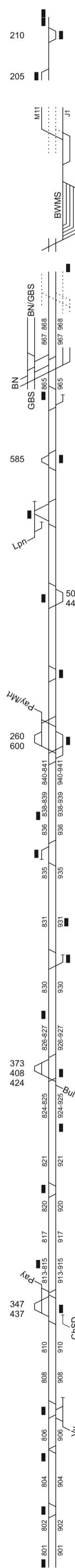
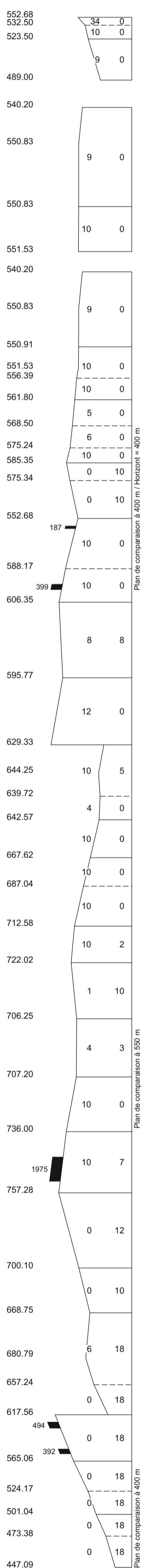

Flamatt
Flamatt Dorf
Neuenegg
Laupen
Bern
Bern JKL
Bern Weyermannshaus
Bern Steigerhubel (Abzw)
Bern
Bern JKL
Bern Weyermannshaus (Spw)
Bern Steigerhubel (Abzw)
Bern Ausserholligen SBB
Bern Bümpliz Süd
Niederwangen
Oberwangen
Thörishaus Station
Thörishaus Dorf
Flamatt
v/n Laupen
Wünnewil
Schmitten
Düdingen
Grandfey
d/p Givisiez (Pay / Mrt)
Fribourg St-Léonard
Fribourg
Glâne
Villars-sur-Glâne
Matran
Rosé
Neyruz
Cottens
Chénens
Villaz-St-Pierre
Romont
d/p Bulle
Siviriez
Vauderens
Oron
d/p Payerne
Palézieux
d/p Châtel-St-Denis
Corbéron
Moreillon
Puidoux-Chexbres
d/p Vevey
Grandvaux
Bossière
La Conversion
Pully-Nord
Lausanne
d/p St-Maurice
Lausanne

0.68	0.00
1.04	0.68
5.08	1.72
	6.80
0.86	97.18
1.32	96.32
0.42	95.00
	94.58
0.86	97.18
1.41	96.32
0.34	94.92
0.47	94.58
1.12	94.11
1.95	93.00
1.67	91.04
1.17	89.37
1.32	88.20
2.81	86.88
	84.07
3.73	80.34
2.48	77.86
5.65	
	72.21
4.71	
1.51	67.50
	65.99
3.87	
	62.12
1.74	
	60.38
2.84	
2.16	57.54
2.96	55.38
	52.42
2.80	
	49.62
4.58	
	45.04
4.84	
	40.20
4.47	
	35.73
5.02	33.71
	33.50
	30.50
6.13	
	24.37
3.77	
	20.60
5.98	
2.46	14.62
	12.16
3.85	
2.53	8.31
1.77	5.78
1.64	4.00
2.37	2.37
	0.00

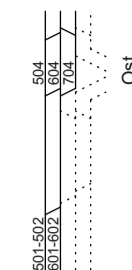
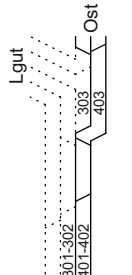

Gl. 300 / 400

Gl. 500 / 600

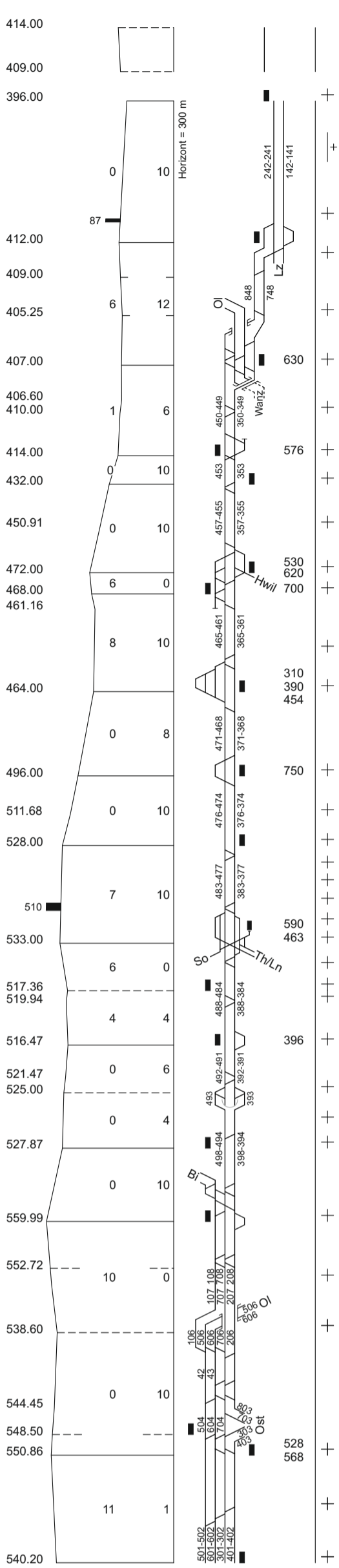

Aarburg-Oftringen Süd (Abzw)	00.83
Aarburg-Oftringen West (Abzw)	0.83
Olten	39.29
Aarburg-Oftringen	43.01
Aarburg-Oftringen West (Abzw)	0.97
Bifang AG (Spw)	0.89
Rothenrist	46.20
Rothenrist Hungerzelg Rank (Spw)	2.87
Murgenthal Roggwil-Wynau	52.22
Gurtelen	2.27
Langenthal	54.49
Langenthal GB	59.11
Langenthal West (Abzw)	1.18
	59.19
	60.38
	0.88
	61.26
	5.46
	66.42
	66.50
	66.79
Herzogenbuchsee	72.33
	5.54
Riedwil	76.93
Lochmatt	4.60
Wynigen	6.46
	5.90
	4.63
v/n Solothurn	
Burgdorf	83.39
v/n Hasle-Rüegsau	3.15
Lyssach Sandacher (Spw)	86.54
	0.66
	87.20
	2.53
Hindelbank	89.73
Hardfeld (Spw)	1.93
Mattstetten (Abzw)	0.32
	91.66
	0.32
	91.98
	2.93
Schönbühl SBB	94.91
	3.89
v/n Biel/Bienne	
Zollikofen	98.81
Zollikofen West (Spw)	1.05
	99.86
	99.88
	1.40
Löchligut	101.28
	1.22
Löchligut Süd (Abzw)	102.50
Bern Wankdorf	0.44
Bern Wylerfeld	102.94
	0.39
	103.33
Lorraine	2.80
Bern	106.13

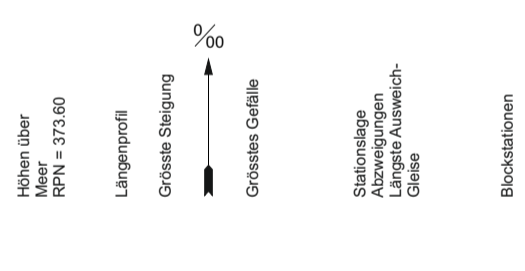

Bern JKLM	
Bern	
Bern JKLM	
Gleise P (J2,J7,J8)	
Gleise G (J1,M11)	
Einfr. von Stat. zu Stat.	
Kilometrierung der Bahn	

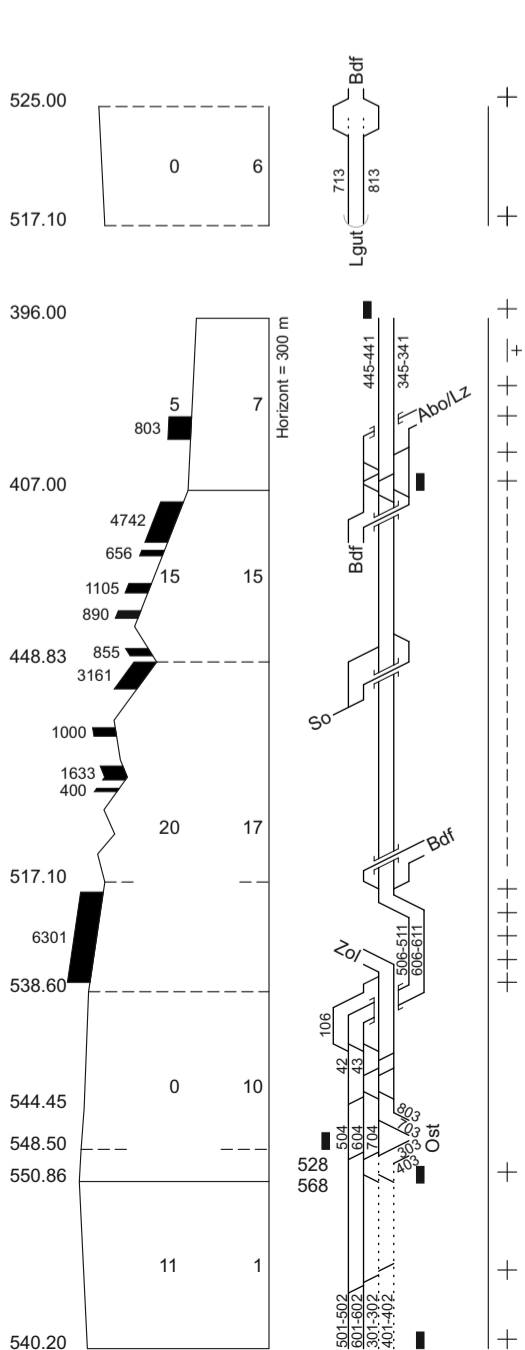

Mattstetten (Abzw)	92.09
Aespli	0.68
	92.77
	12.28
Olten Nord-Ost (Abzw)	
Olten	39.29
	5.86
Rothenrist	45.15
v/n Burgdorf	46.20
	47.35
	55.29
	19.39
Wanzwil (Abzw)	36.98
v/n Solothurn	
	24.71
v/n Burgdorf	
Aespli	12.28
Löchligut	7.43
	4.85
	101.28
	1.22
Löchligut Süd (Abzw)	102.50
Bern Wankdorf	0.44
Bern Wylerfeld	102.94
	0.39
	103.33
Lorraine	2.80
Bern	106.13

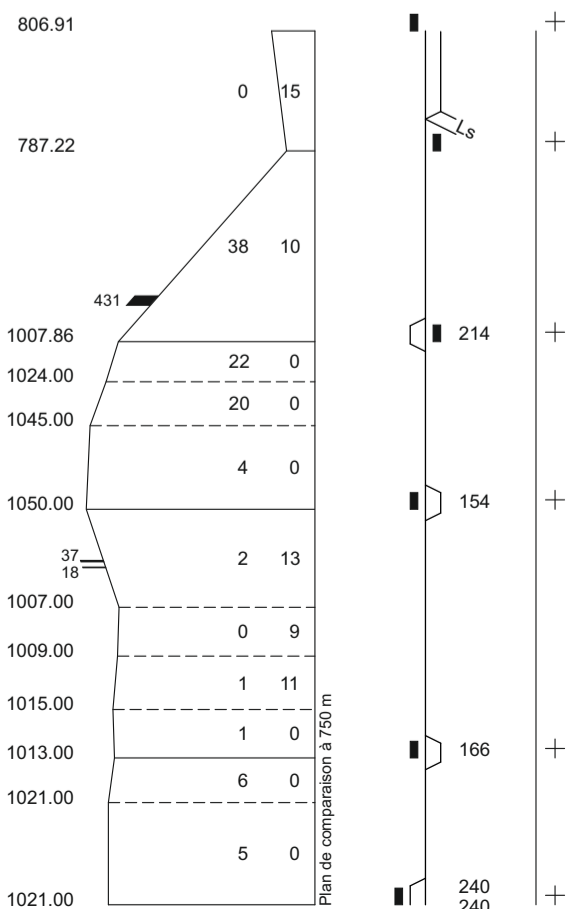

Altitude au dessus de la mer
RPN = 373.60

Profil en long

Pente maximum
Rampe maximum

Situation des stations, bifurcations, plus longues voies d'évitement

Stations de block

Distance de stat. à stat.
Kilométrage de la voie

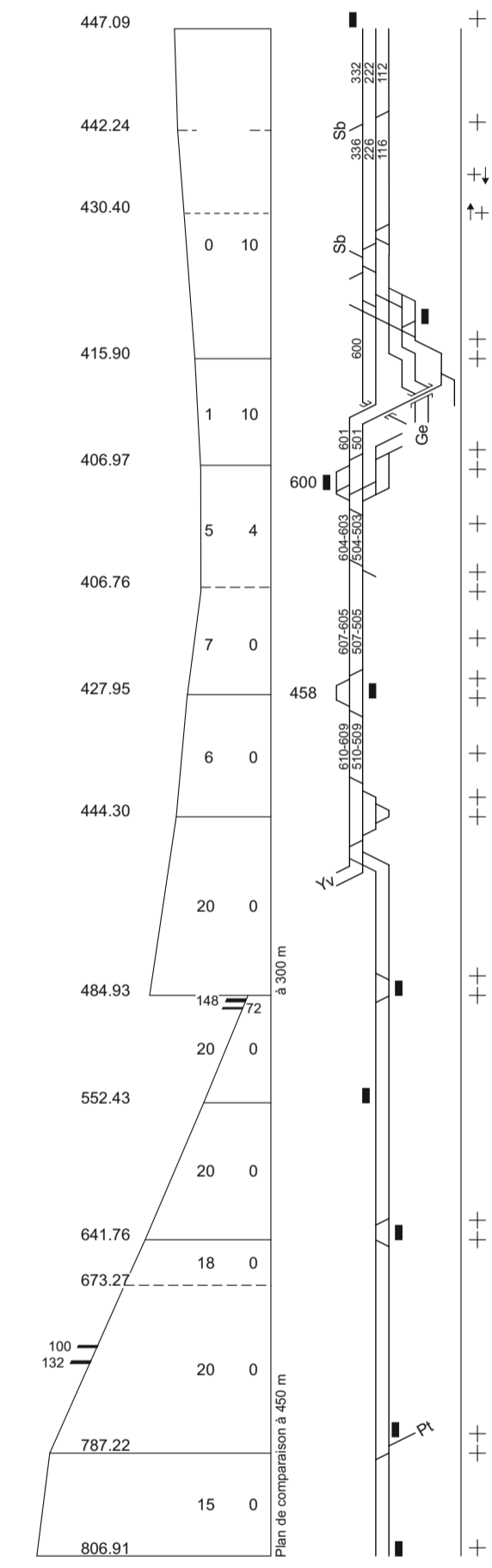

Altitude au dessus de la mer
RPN = 373.60

Profil en long

Pente maximum
Rampe maximum

Situation des stations, bifurcations, plus longues voies d'évitement

Stations de block

Distance de stat. à stat.
Kilométrage de la voie

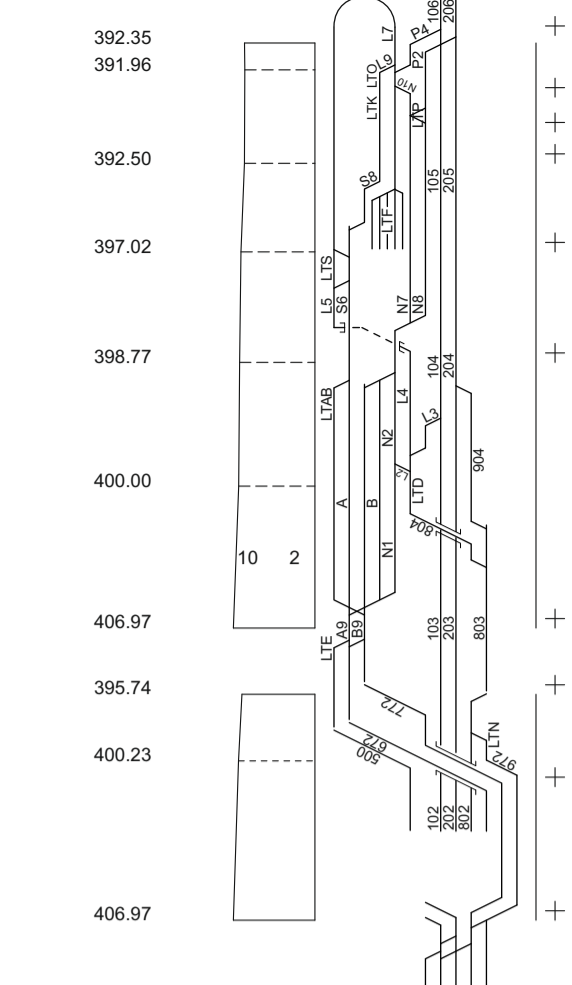

Altitude au dessus de la mer
RPN = 373.60

Profil en long

Pente maximum
Rampe maximum

Situation des stations, bifurcations, plus longues voies d'évitement

Stations de block

Distance de stat. à stat.
Kilométrage de la voie

Lausanne-Triage F	9.30
Lausanne-Triage Ouest	0.51
Record Buchet	9.81
Praz Lebaz	1.67
Lausanne-Triage Sud	11.48
Bosse	1.37
Lausanne-Triage D	12.85
	0.36
Lécheires (bif)	13.21
	0.63
Lausanne-Triage Nord	13.84
voie 972	1.08
Bussigny	14.92
Lausanne-Triage A/B	8.10
Lausanne-Triage E	0.98
voie 772	7.12
	13.39
Bussigny	14.92

d/p Vevey

d/p Palézieux		
Lausanne	0.00	
	1.13	
Lausanne (bif)	1.13	
	1.22	
Prilly-Malley	2.35	
	1.40	
Renens VD Est (bif)	3.75	
Renens VD	0.76	
Renens VD Ouest (bif)	4.51	
d/p Genève (voies 201/101)	0.99	
d/p Lausanne-Triage	1.43	
Bussigny	6.93	
Fallien	4.05	
Vufflens-la-Ville	10.97	
Gollion	3.51	
Cossonay	14.49	
Vaux	3.92	
Dailens	18.41	
d/p Yverdon-les-Bains	4.34	
La Sarraz	22.75	
Arnex	4.82	
	6.14	
Croy-Romainmôtier	33.70	
Bretonnières	2.12	
	7.46	
d/p Le Brassus	43.28	
Le Day	3.03	
Vallorbe	46.31	
Vallorbe-Frontière	SNCF 461.60	

Vallorbe	46.31	0.00
	3.03	
Le Day	43.28	3.03
d/p Lausanne	8.60	
Le Pont	11.63	
Charbonnières	0.91	11.28
Séchéy	1.08	12.19
Le Lieu	2.19	13.27
	2.45	15.45
Esserts-de-Rive	17.90	
Le Rocheray	1.15	19.05
Solliat-Golisse	1.44	20.50
Sentier-Orient	1.15	21.65
Chez-le-Maitre-Ecoles	1.07	22.72
	1.68	
Le Brassus	24.40	

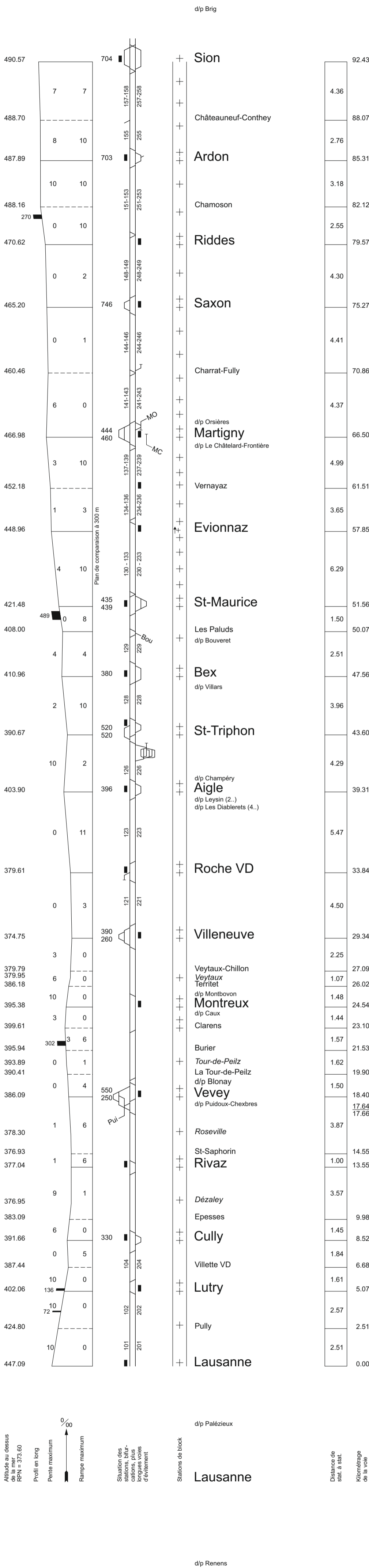

d/p Brig

d/p Palézieux

d/p Renens

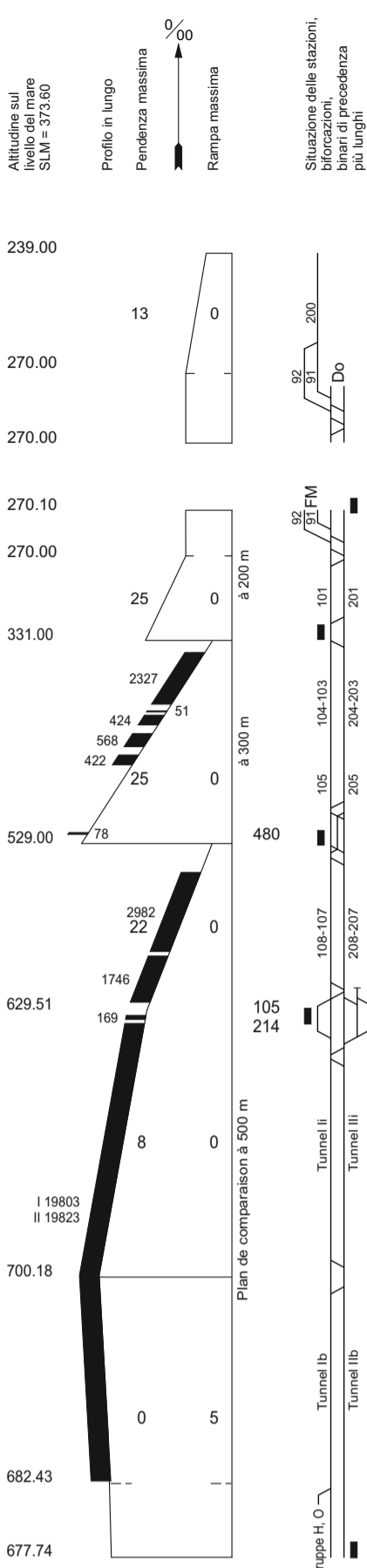
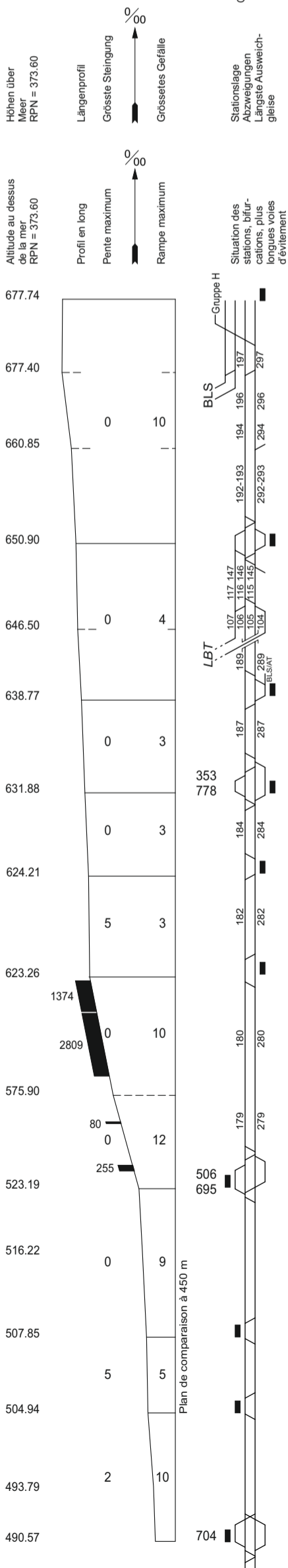

d/p St-Maurice

Sion

Clavoz

St-Léonard

Granges-Lens

Noës

Sierre/Siders

Salgesch

Leuk

Turtmann

Gampel-Steg

Raron

St. German (Abzw)

Visp

Gamsen SBB

Brig Lötschberg (Abzw)

Brig

Stations de block

v/n Thun

Brig (Bahnhofplatz)

v/n Furka

Brig Tunnel

Staz. della Galleria Sempione

Iselle di Trasquera

Galleria elicoidale

Varzo

Mognatta

Rio Rido

Preglia

Domodossola (bif)

Domodossola

Domodossola FM

Domodossola II

Domodossola

d/p Locarno

d/p Milano

92.43

5.72

98.15

101.56

6.57

108.13

4.12

112.25

5.33

117.58

118.80

125.86

122.11

3.75

125.87

125.86

4.22

130.09

3.19

133.28

50.06

3.45

136.73

4.71

141.44

3.81

145.25

0.30

145.55

Distance de stat. a stat.

Kilométrage de la voie

v/n Zermatt

Brig

Blockstationen

v/n Furka

Brig (Bahnhofplatz)

Entf. von Stat. zu Stat.

Kilometrierung der Bahn

147.15

1.60

1.60

145.55

1.60

147.15

1.60

145.55

1.60

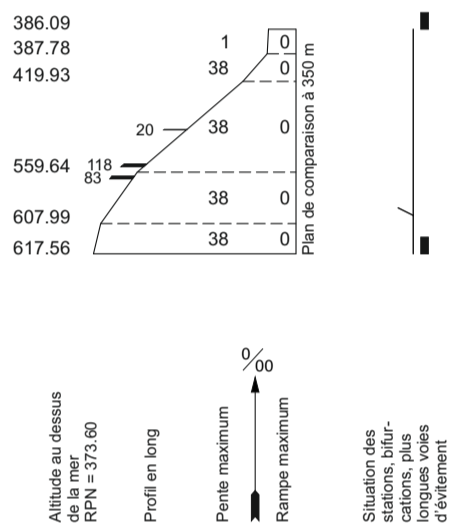

Altitude au dessus de la mer
RPN = 373.60

Profil en long

Pente maximum 0/100

Rampe maximum

Situation des stations, bifurcations, plus longues voies d'évitement

Stations de block

d/p Lausanne

Puidoux-Chexbres

Distance de stat. à stat.	0.85	0.00
Kilométrage de la voie	0.90	0.85
	3.86	1.75
	1.49	5.61
	0.73	7.10
		7.83

d/p Palézieux

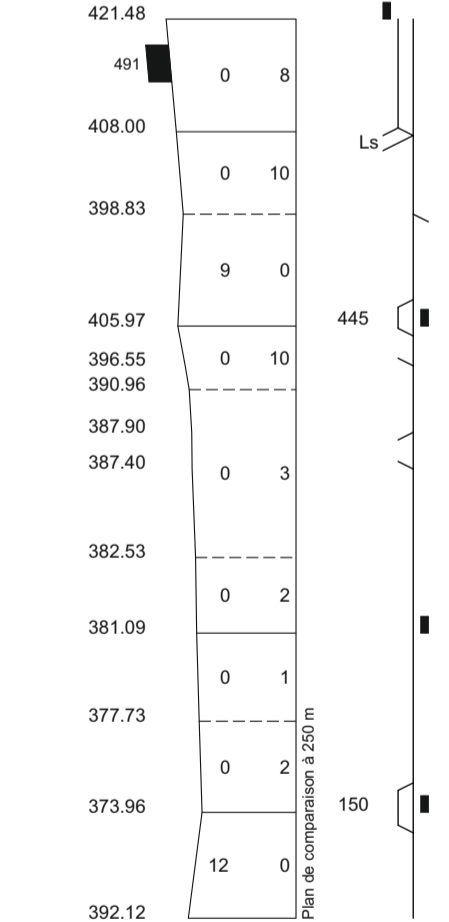

Altitude au dessus de la mer
RPN = 373.60

Profil en long

Pente maximum 0/100

Rampe maximum

Situation des stations, bifurcations, plus longues voies d'évitement

Stations de block

d/p Lausanne

Puidoux-Chexbres

Distance de stat. à stat.	0.85	0.00
Kilométrage de la voie	0.90	0.85
	3.86	1.75
	1.49	5.61
	0.73	7.10
		7.83

d/p Palézieux

d/p Sion

St-Maurice

	1.50	51.56
--	------	-------

Les Paluds
d/p Lausanne

	1.73	50.07
		1.47

Massongex

	2.85	3.20
--	------	------

Monthey

	1.16	6.05
--	------	------

Monthey Giovanola (embr)
Collombey

	0.70	7.21
		7.91

Monthey centre agr Bas-Valais (embr)
Monthey AGIP (embr)

	1.18	9.09
	1.00	10.09

Vionnaz

	3.30	13.39
--	------	-------

Vouvry

	2.87	16.25
--	------	-------

Les Evouettes

	3.27	19.53
--	------	-------

Bouveret

	3.39	22.91
--	------	-------

St-Gingolph (Suisse)

	3.89	26.80
--	------	-------

d/p Lausanne

Vevey

d/p Sion

Vevey

	0.85	0.00
--	------	------

Vevey-Funi
Corseaux-Cornalles

	0.90	0.85
		1.75

Chexbres-Village

	3.86	5.61
--	------	------

Le Verney (embr)

	1.49	7.10
--	------	------

Puidoux-Chexbres

	0.73	7.83
--	------	------

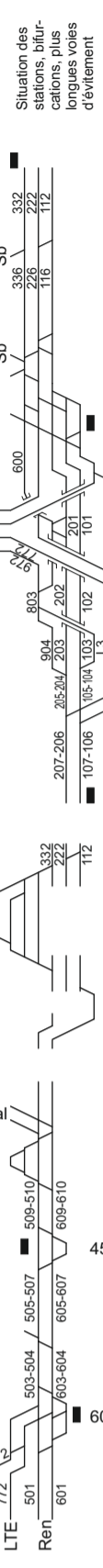
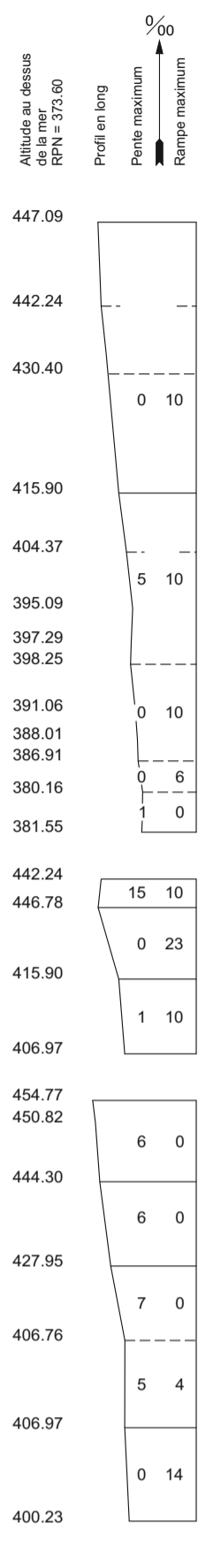
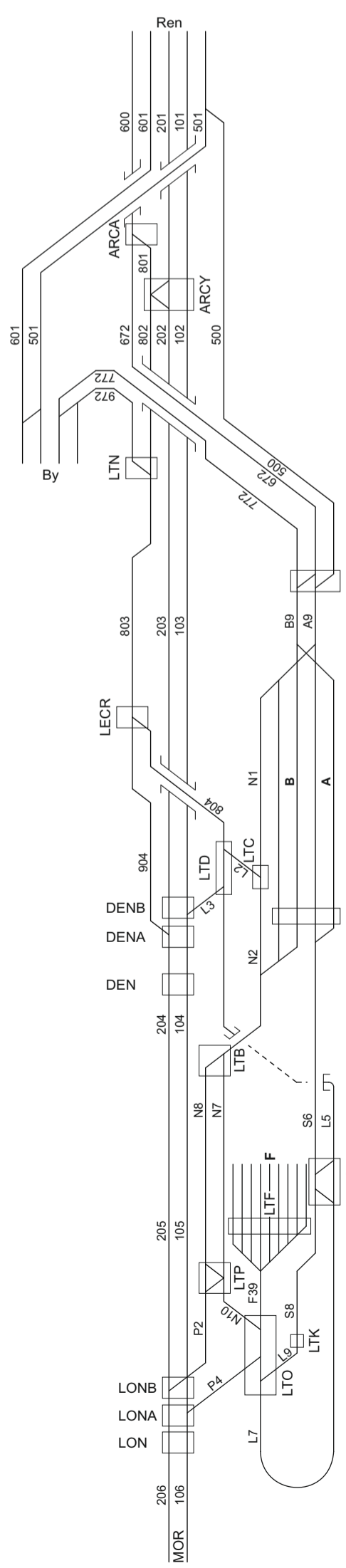

Stations de block	Distance de stat. à stat.	Kilométrage de la voie
Lausanne		0.00
Lausanne (bif)	1.13	1.13
Prilly-Malley	1.22	2.35
Renens VD Est (bif)	1.41	3.76
Renens VD	0.75	4.51
Renens VD Ouest (bif)	0.99	5.50
d/p Dailens	0.81	6.31
Archy (bif)	1.72	8.03
<i>Venoge</i>	0.24	8.27
Denges B (bif)	0.11	8.38
Denges A (bif)	1.33	9.71
Denges-Echandens	0.29	10.00
<i>Denges Lonay B (bif)</i>	0.12	10.12
Lonay A (bif)	1.04	11.16
Lonay-Préverenges	1.34	12.50
Morges-St-Jean		
Morges		
Lausanne (bif)	0.39	1.13
Lausanne-Sébeillon	2.24	1.52
Renens VD Est (bif)	0.75	3.76
Renens VD	0.99	4.51
Renens VD Ouest (bif)	1.43	5.50
Bussigny		6.93
Eclépens		21.38
Eclépens sud	0.79	20.59
d/p Vallorbe	2.18	
Dailens		18.41
<i>Vaux</i>	3.92	
Cossonay		14.49
<i>Gollion</i>	3.51	
Vufflens-la-Ville	4.05	10.97
<i>Fallien</i>		
Bussigny		6.93
d/p LTN voie 972	1.53	14.92
Lausanne-Triage Est		13.39
voie 772		
Renens VD		4.51
Renens VD Ouest (bif)	0.99	5.50
voie 500	1.62	7.12
Lausanne-Triage Est		
Renens VD		4.51
Renens VD Ouest (bif)	0.99	5.50
Archy A (bif)	0.41	5.91
voie 672	1.35	7.26
Lausanne-Triage Est	0.98	7.12
voies A9/B9	0.40	8.10
Lausanne-Triage A/B		8.50
Lausanne-Triage B		
Lausanne-Triage Est		7.12
voie N1	0.84	7.96
Lausanne-Triage C		8.50
voie N2	0.91	9.41
Lausanne-Triage B		
voie N7/8	0.31	9.72
Lausanne-Triage P1	0.30	9.70
Lausanne-Triage Ouest		10.00
Lonay A (bif)		
Lausanne-Triage A/B		8.10
voie S6	0.84	9.38
Lausanne-Triage Sud		8.94
		11.59
voie P4	0.70	10.89
Lausanne-Triage K		10.65
voie L9	0.24	10.90
Lausanne-Triage Ouest		
Lausanne-Triage P1		9.40
voie P2	0.30	9.70
Lonay B (bif)		14.92
Bussigny		
voie 972	1.08	13.84
Lausanne-Triage Nord		7.96
Lausanne-Triage C		0.26
voie L2	0.70	7.72
Lausanne-Triage D		8.03
voie L3	0.31	8.27
Denges B (bif)		8.27
Denges A (bif)		7.36
voie 904	0.91	8.10
Lécheires (bif)		
Renens VD		4.51
Renens VD Ouest (bif)	0.99	5.50
Archy A (bif)	0.41	5.91
voie 801	0.22	6.12
Archy (bif)	0.62	6.75
Lausanne-Triage Nord		13.84
voie 802		
voie 803	0.63	13.21
Lécheires (bif)		12.85
Lausanne-Triage D	0.36	11.48
<i>Bosse</i>	1.37	
Lausanne-Triage Sud		
<i>Praz Lebaz</i>		
voie L7	1.67	9.81
<i>Record Buchet</i>		
Lausanne-Triage Ouest		9.72
Lausanne-Triage F	0.51	

d/p Vevey

d/p Palézieux

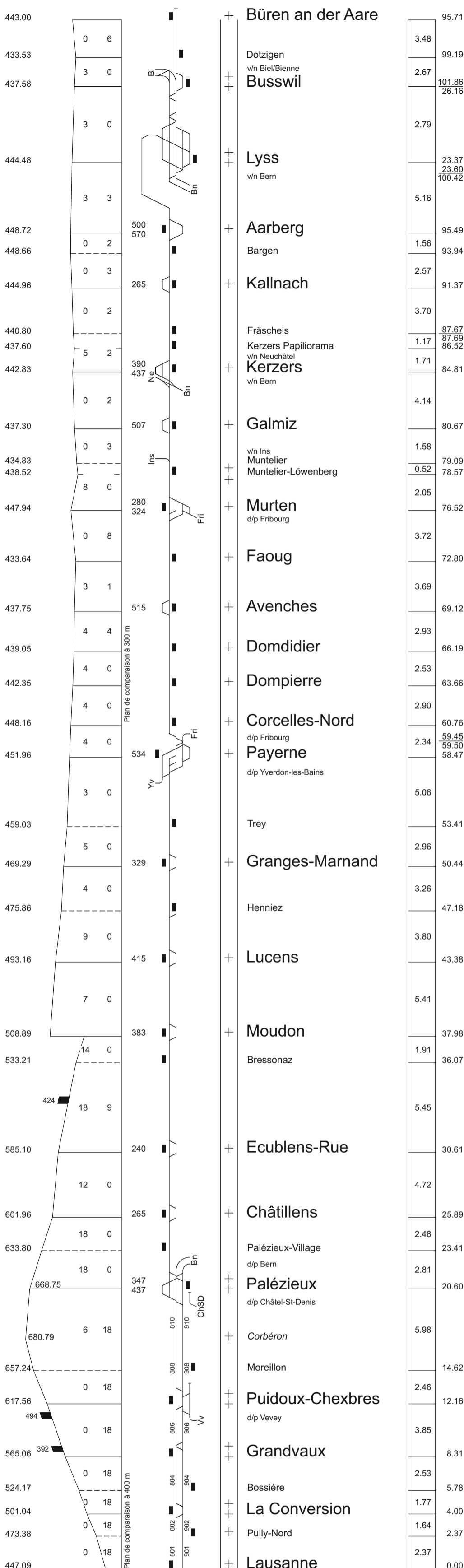

Altitude au dessus de la mer RPN = 373.60

Profil en long

Pente maximum

Rampe maximum

Situation des stations, bifurcations, plus longues voies d'évitement

Stations de block

d/p Vevey

Lausanne

d/p Renens

Distance de stat. à stat.

Kilométrage de la voie

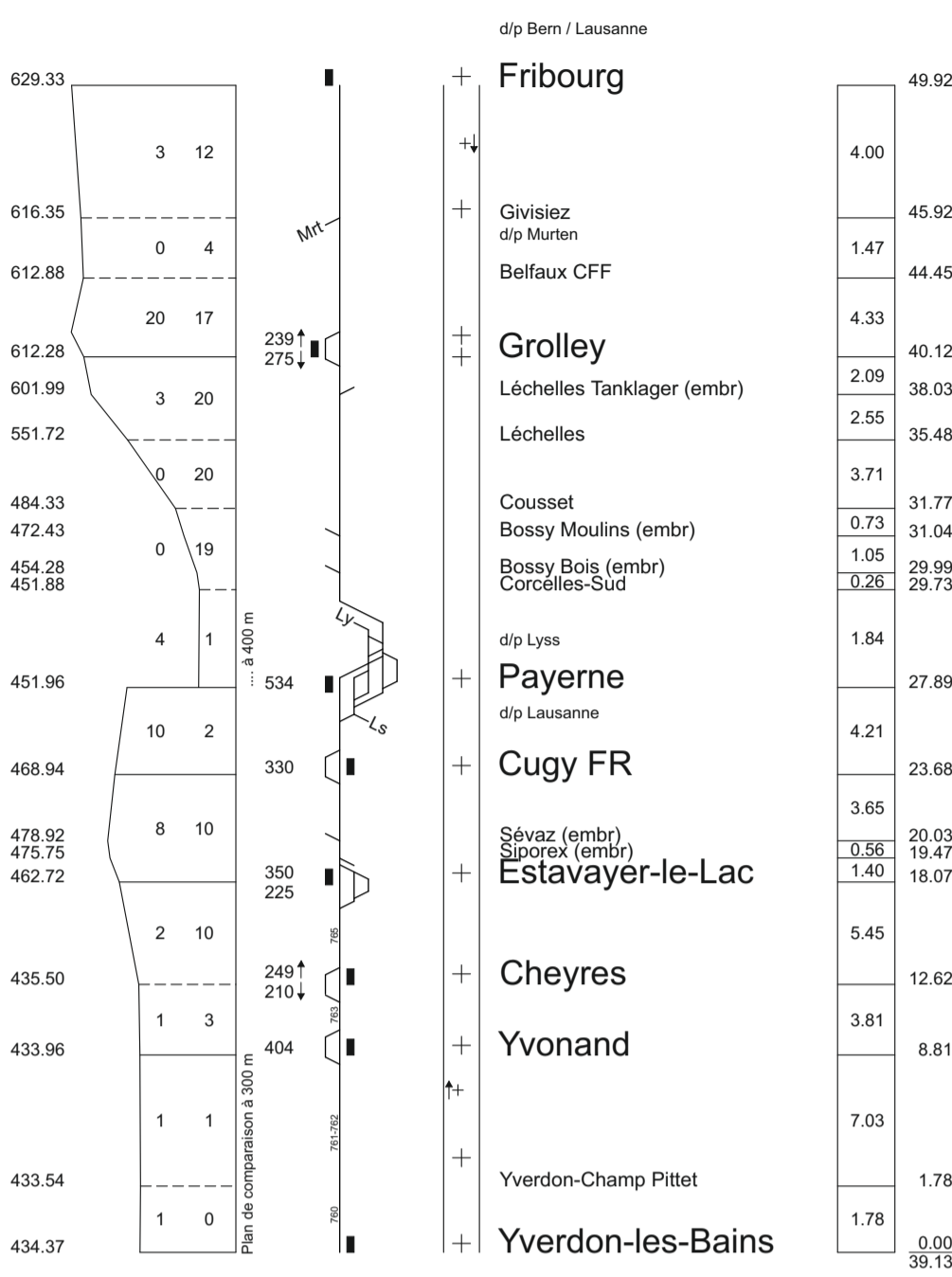
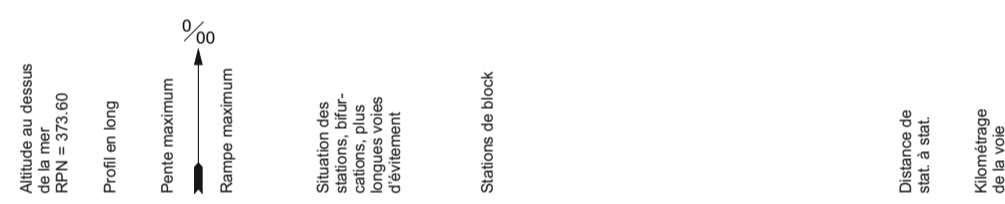

d/p Bern / Lausanne

d/p Lausanne

d/p Neuchâtel

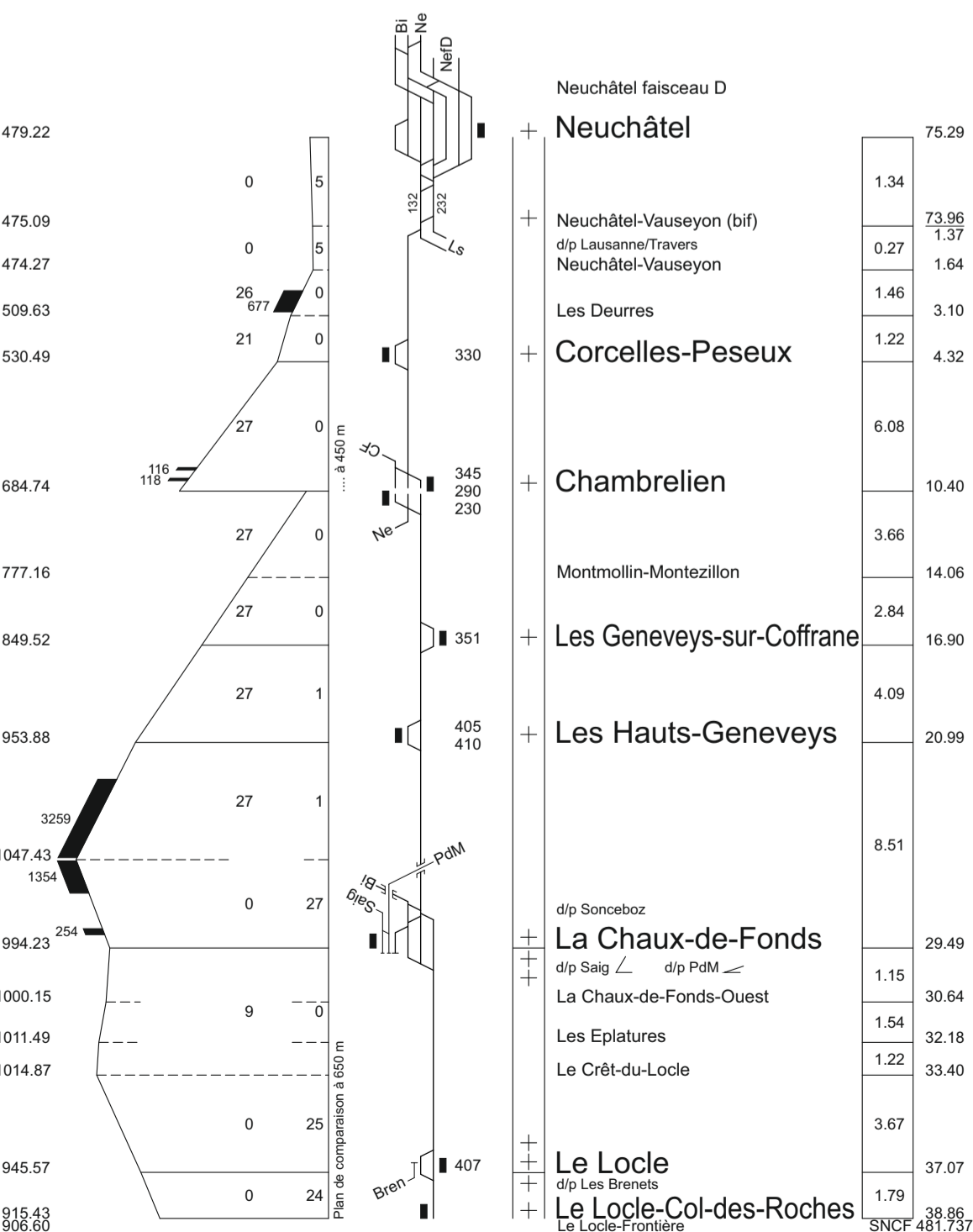
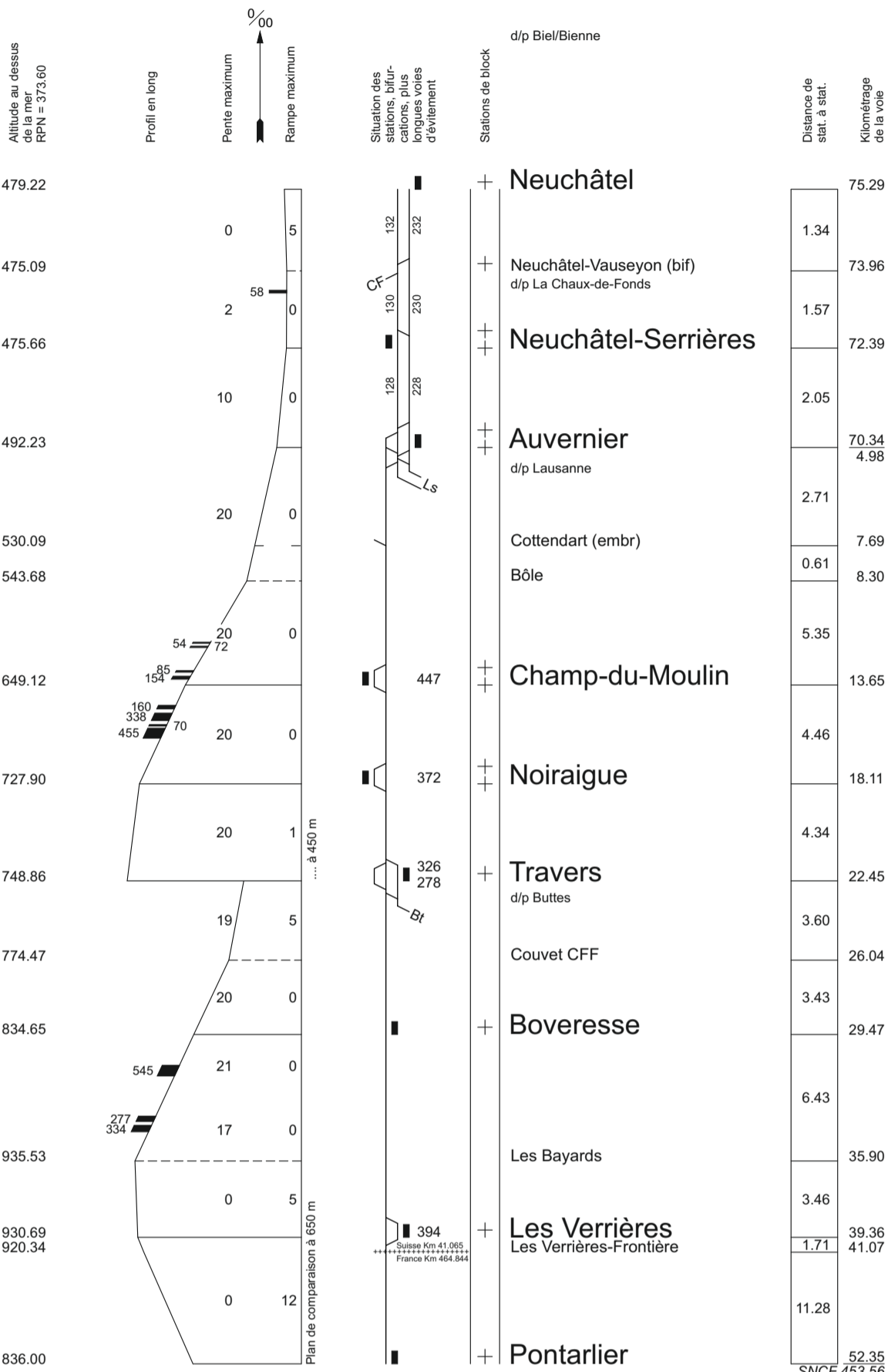

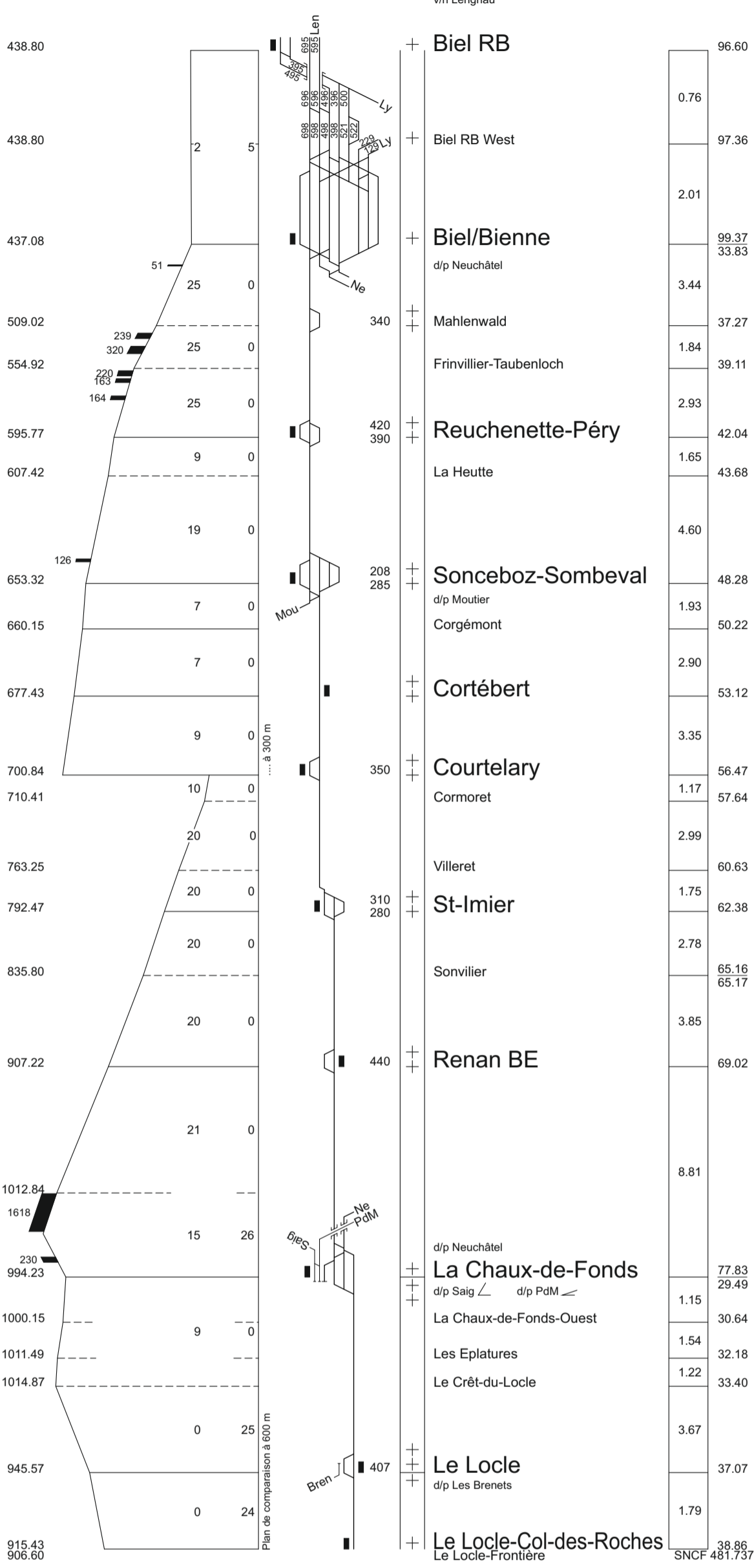

Altitude au dessus de la mer (RPN = 373.60)
Profil en long
Pente maximum (‰)
Rampe maximum
Situation des stations, bifurcations, plus longues voies d'évitement
Stations de block
d/p Biel/Bienne
Distance de stat. à stat.
Kilométrage de la voie

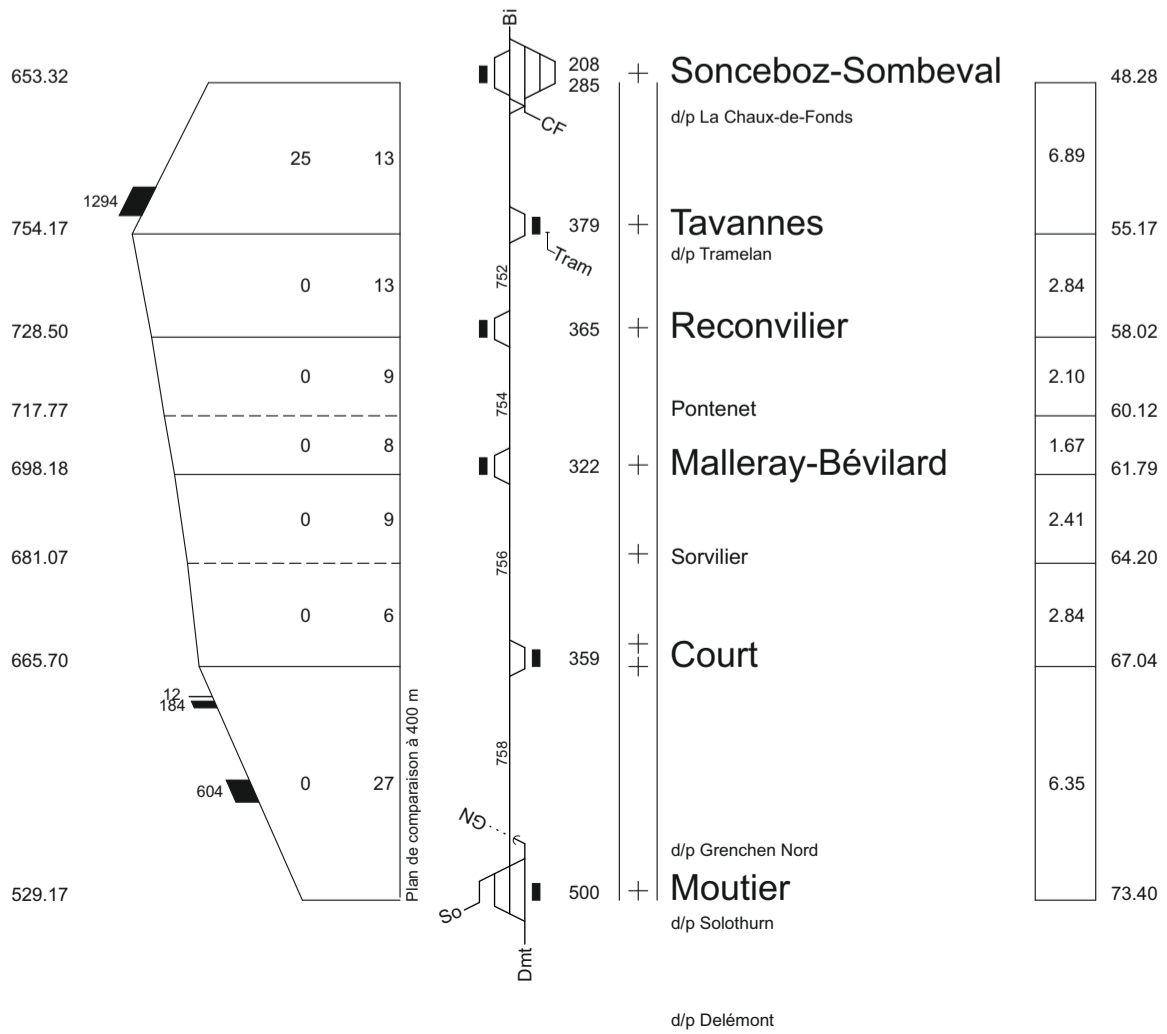

Altitude au dessus de la mer (RPN = 373.60)
Profil en long
Pente maximum (‰)
Rampe maximum
Situation des stations, bifurcations, plus longues voies d'évitement
Stations de block
d/p Delémont

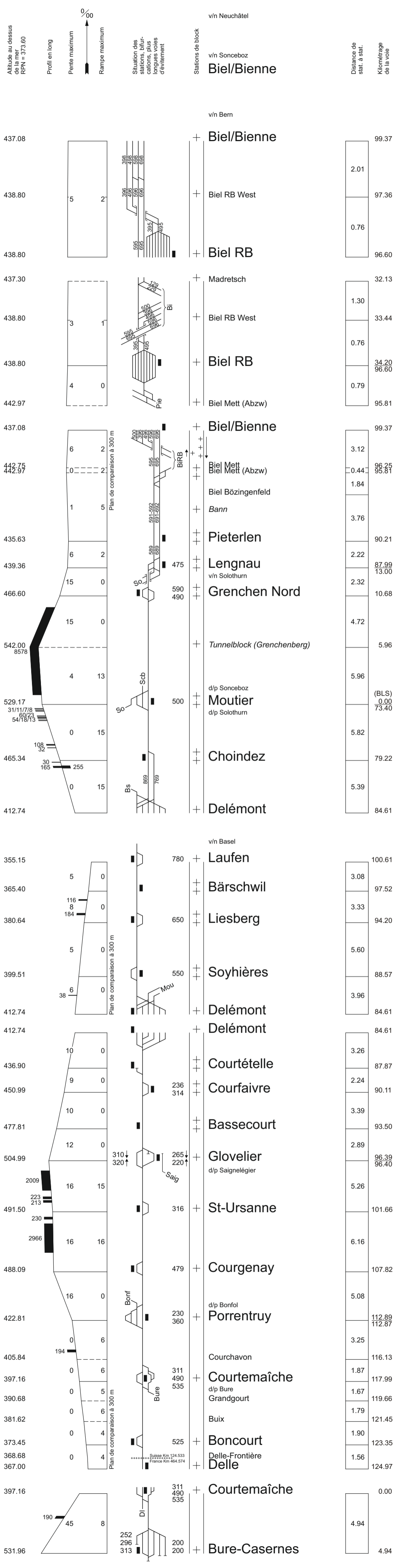

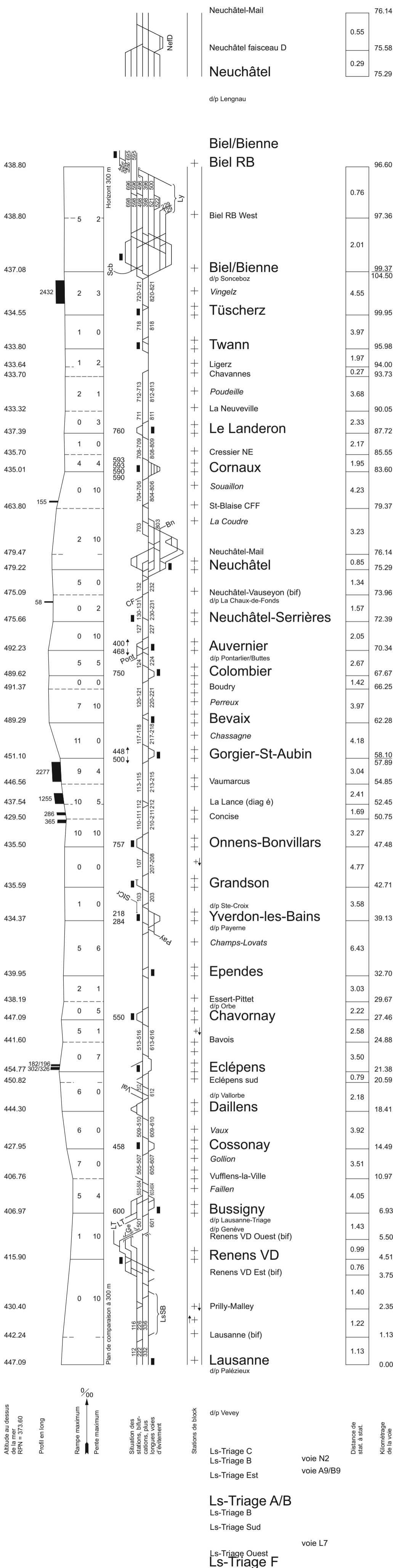

Höhen über Meer
RPN = 373.60

Längenprofil
Grösstes Gefälle
Grösste Steigung

Stationslage
Abzweigungen
Längste Ausweichgleise

Blockstationen

Entf. von Stat. zu Stat.
Kilometrierung der Bahn

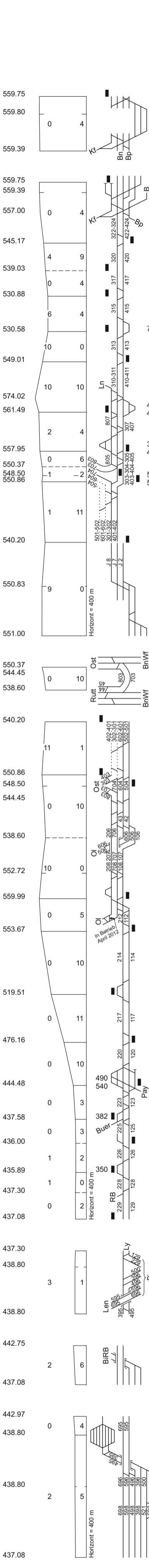

v/n Spiez

Thun Schadau (Abzw)

+	Thun		137.02
+	Thun Gruppe B	0.29	136.73
		0.58	
+	Thun (Abzw)		136.15

+	Thun		137.02
+	Thun (Abzw)	0.87	136.15
+	Lerchenfeld	1.52	134.63
+	Allmend	3.53	
+	Uttigen	2.79	131.10
+	Kiesen	2.57	128.30
+	Wichtrach	3.60	125.73
+	Münsingen	3.09	122.13
+	Rubigen	3.67	119.04
+	Allmendingen		
+	v/n Langnau		
+	Gümligen Süd (Abzw)	1.41	115.37
+	Gümligen	3.19	113.96
+	Dennigkofen		
+	Ostermündigen	1.28	110.77
+	Wankdorf (Abzw)	0.51	109.48
+	Bern Wankdorf	0.39	108.97
+	Bern Wylerfeld	0.39	108.58
			103.33
+	Lorraine	GI. 300 / 400	2.80
+	Bern		106.16
			97.10
+	Bern JKLM	0.78	96.32
		1.32	
+	Bern Weyermannshaus		95.00

+	Wankdorf (Abzw)		103.17
+	Löchligut Süd (Abzw)	0.67	102.50
+	Löchligut	1.22	101.28

+	Bern		106.16
+	Lorraine	GI. 500 / 600	2.83
+	Bern Wylerfeld		103.33
+	Bern Wankdorf	0.38	102.95
+	Löchligut Süd (Abzw)	0.45	102.50
		1.22	
+	Löchligut		101.28
	v/n Olten	1.40	
+	Zollikofen West (Spw)	99.88	99.86
+	Zollikofen	1.05	98.81
	v/n Olten		(7.46)
+	Münchenbuchsee	2.66	10.12
		5.57	
+	Schüpfen		15.69
		4.23	
+	Suberg-Grossaffoltern		19.92
		3.44	
+	Lyss		23.37
	v/n Payeme	2.79	
+	Busswil		26.16
	v/n Büren a. d. Aare		
+	Studen Auto	1.96	28.12
	Studen BE	2.39	
+	Brügg BE		30.51
		1.62	
+	Madretsch		32.13
	v/n Biel RB		33.07
+	Biel/Bienne	1.46	98.84
			99.37

+	Madretsch		32.13
+	Biel RB West	1.30	33.44
		0.76	97.36
+	Biel RB		96.60

+	Biel Mett		96.25
+	Biel/Bienne	3.12	99.37

+	Biel Mett (Abzw)		95.81
+	Biel RB	0.79	96.60
		0.76	
+	Biel RB West		97.36

+	Biel/Bienne	2.01	99.37
---	-------------	------	-------

v/n Neuchâtel

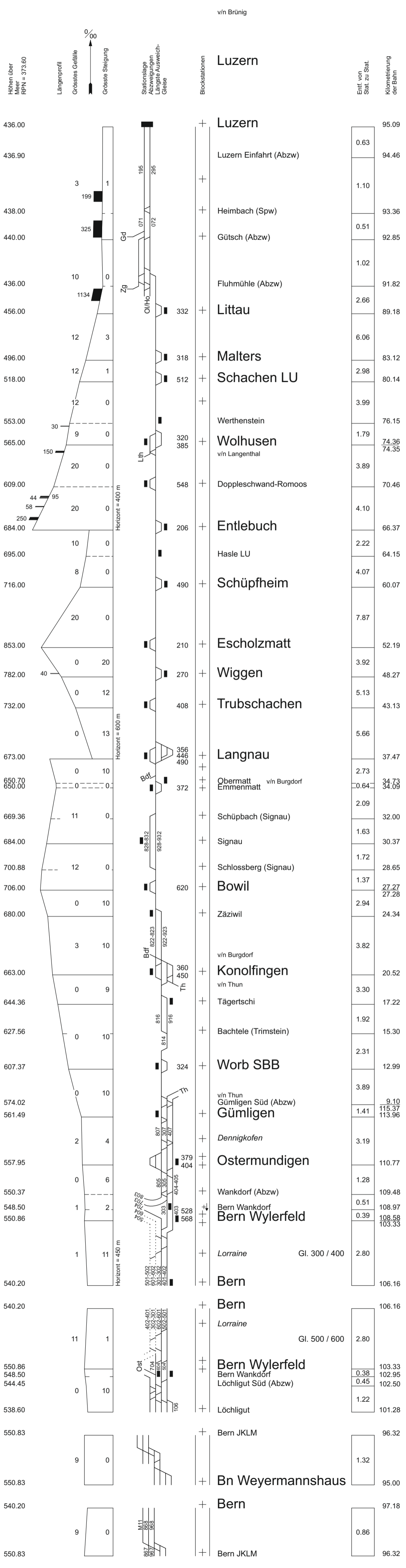

35 A

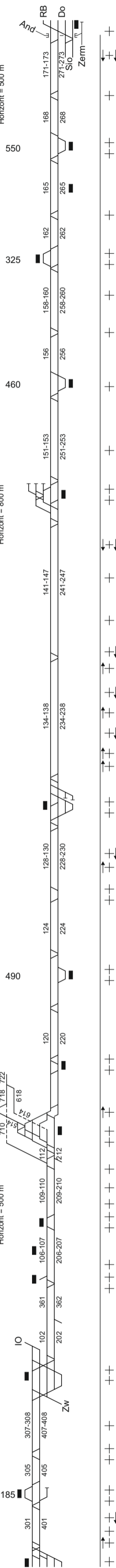
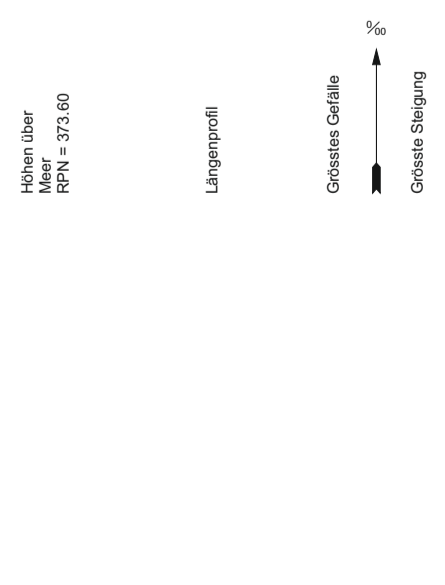
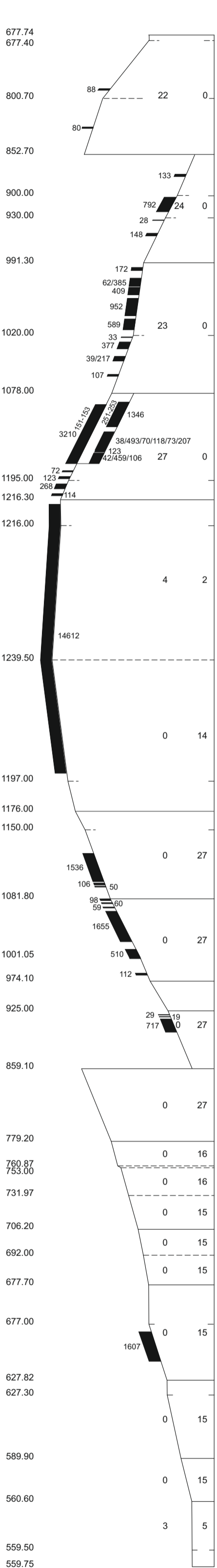

Brig	Brig-Lötschberg (Abzw)	-0.30	73.81
		3.16	73.51
	Mundbach (Spw)		70.35
		3.06	
Lalden			67.29
	Eggerberg	2.29	64.99
	Viktoria (Spw)	1.30	63.70
		2.43	
Ausserberg			61.27
		3.98	61.28
	Rarnerkumme (Spw)		57.30
		3.11	
Hohtenn			54.19
		4.73	
	Stockgraben (Spw)		49.46
Goppenstein		1.02	48.44
	Goppenstein Lötschberg (Spw)	1.41	47.03
		7.27	
	Tunnelstation Lötschberg (Spw)		39.76
		6.51	
	Eggenschwand (Spw)		33.26
		1.69	
Kandersteg			31.57
	Bühl (Spw)	1.07	30.50
		3.72	
Felsenburg			26.78
		3.11	
	Fürten (Spw)		23.68
		1.33	
Blausee-Mitholz			22.35
	Grubi (Spw)	1.70	20.65
		3.20	
Kandergrund			17.45
		3.92	
Frutigen			13.54
	Winklen (Spw)	1.51	12.03
	Wengi (AnG)	0.16	11.87
		1.59	
	Wengi-Ey (Abzw)		10.28
			9.97
			9.97
Reichenbach im Kandertal		1.93	8.29
	Mülenen	1.44	6.85
		1.68	
Heustrich-Emdthal			5.16
		2.17	
	Hondrich Süd (AnG)		2.99
			2.90
		3.00	0.00
Spiez			-0.106
	Spiez (Abzw)	0.89	9.78
		3.46	
Einigen			5.44
		2.33	
Gwatt			3.10
		2.62	
	Thun Schadau (Abzw)		0.49
Thun		0.06	137.59
		1.00	137.02

Wichtiger Hinweis:
Um die Lesbarkeit des Fahrplanes zu erhöhen, wurde auf die Darstellung der Verkehrsperioden (VP) bei den Zügen der Seite 28000-28999 verzichtet.

Thun			
Thun Gruppe B			
Thun (Abzw)			
Thun			
Thun (Abzw)			
Lerchenfeld			

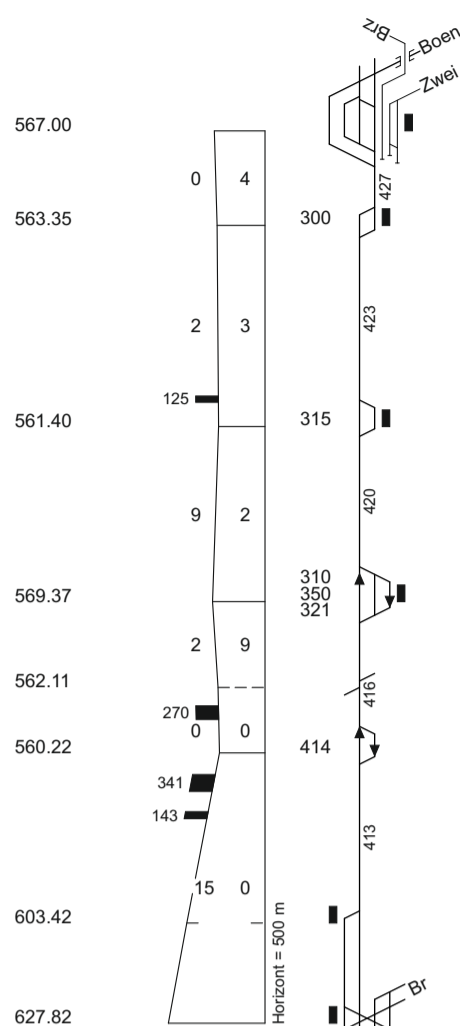

v/n Meiringen

v/n Zweilütschinen

Interlaken Ost

+	Interlaken Ost	27.95
+	Interlaken West	1.93
+		4.01
+	Därlichen	22.02
+		3.52
+	Leissigen	18.50
+		18.49
+	Leissigbad (Agl)	1.79
+	Krattighalde	1.30
+		3.44
+	Faulensee	11.96
+		11.88
+	Spiez	2.02
+		9.78

Höhen über Meer
RPN = 373.60

Längenprofil
Grösstes Gefälle
Grösste Steigung

Stationslage
Abzweigungen
Längste Ausweich-
Gleise

Blockstationen

v/n Brig

Spiez

Spiez (Abzw)

v/n Thun

Entf. von Stat. zu Stat.

Kilometrierung der Bahn

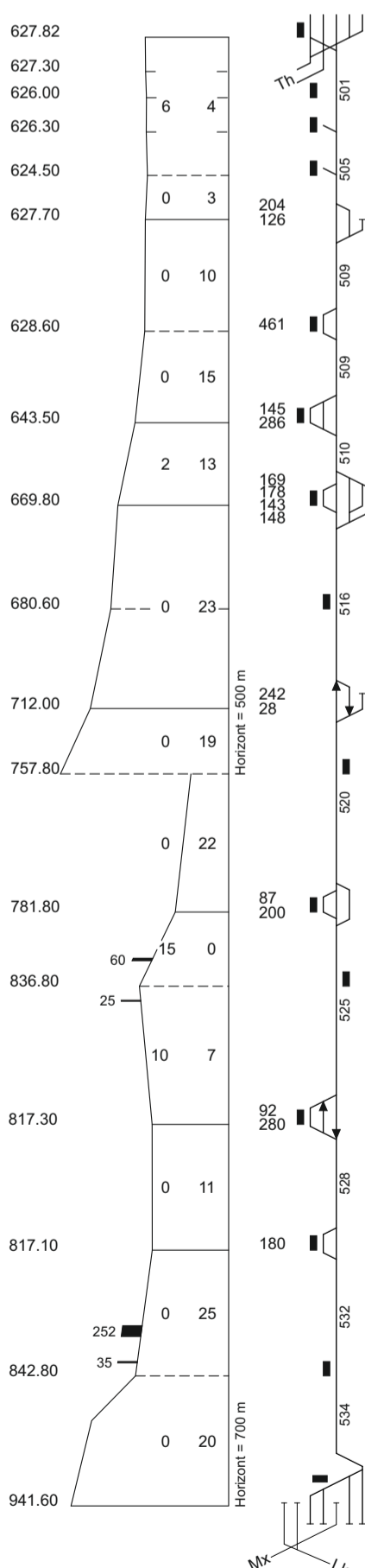

Spiez

Spiez (Abzw)

Spiezmoos Süd

Lattigen bei Spiez

Eifeld

Wimmis

Burgholz

Oey-Diemtigen

Erlenbach im Simmental

Ringoldingen

Därstetten

Weissenburg

Oberwil im Simmental

Enge im Simmental

Boltigen

Weissenbach

Grubenwald

Zweisimmen

Zweisimmen

v/n Lenk

v/n Gstaad

+		0.00
+	Spiez (Abzw)	0.89
+	Spiezmoos Süd	0.69
+	Lattigen bei Spiez	0.88
+	Eifeld	1.04
+	Wimmis	1.05
+		2.61
+	Burgholz	7.16
+		2.18
+	Oey-Diemtigen	9.33
+	Erlenbach im Simmental	1.96
+		11.29
+		2.50
+	Ringoldingen	13.79
+		2.31
+	Därstetten	16.10
+	Weissenburg	1.54
+		17.64
+		3.25
+	Oberwil im Simmental	20.90
+	Enge im Simmental	1.73
+		22.63
+		3.28
+	Boltigen	25.90
+		2.98
+	Weissenbach	28.89
+		2.94
+	Grubenwald	31.82
+		3.08
+	Zweisimmen	34.90

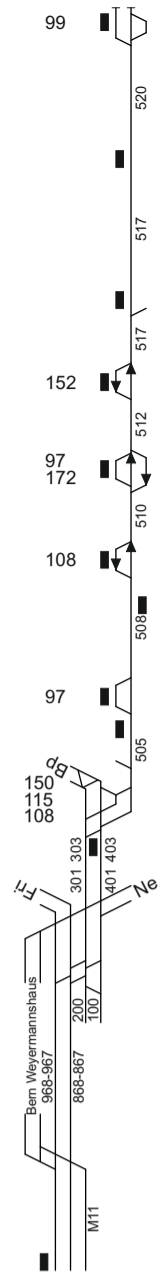
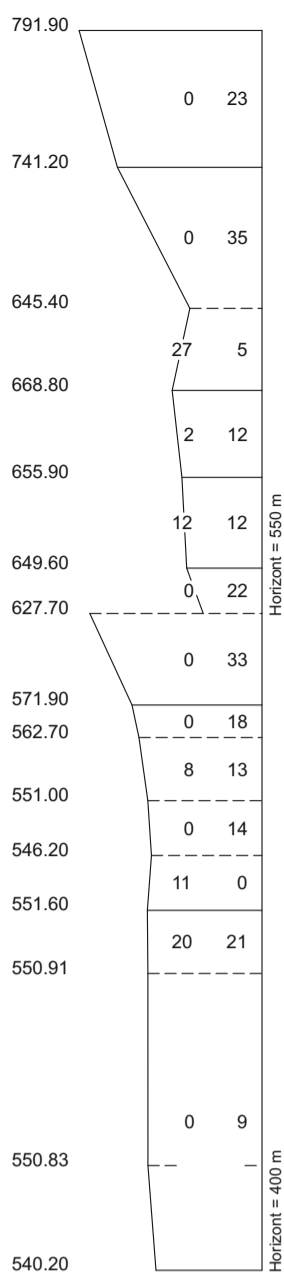

Blockstationen	Entf. von Stat. zu Stat.	Kilometerung der Bahn
Bern	0.86	97.18
Bern JKLM		96.32
Bern Weyermannshaus (Spw)	1.41	94.92
Bern Holligen	0.48	2.71
Bern Ausserholligen GBS	0.41	3.12
Bern Fischermätteli (Abzw)	0.40	3.52
Köniz	0.72	5.00
Liebefeld	1.47	5.71
Moos	2.08	7.80
Gasel	1.08	8.87
Niederscherli	2.01	10.89
Mittelhäusern	1.94	12.82
Schwarzwasserbrücke	1.83	14.66
Lanzenhäusern	3.18	17.83
Schwarzenburg	3.04	20.87

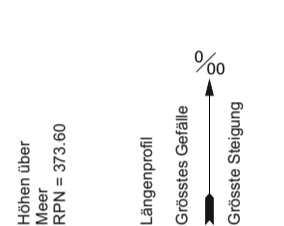

Blockstationen	Entf. von Stat. zu Stat.	Kilometerung der Bahn
Bern	0.86	97.18
Bern JKLM		96.32
Bern Weyermannshaus (Spw)	1.41	94.92
Bern Holligen	0.48	2.71
Bern Ausserholligen GBS	0.41	3.12
Bern Fischermätteli (Abzw)	0.40	3.52
Köniz	0.72	5.00
Liebefeld	1.47	5.71
Moos	2.08	7.80
Gasel	1.08	8.87
Niederscherli	2.01	10.89
Mittelhäusern	1.94	12.82
Schwarzwasserbrücke	1.83	14.66
Lanzenhäusern	3.18	17.83
Schwarzenburg	3.04	20.87

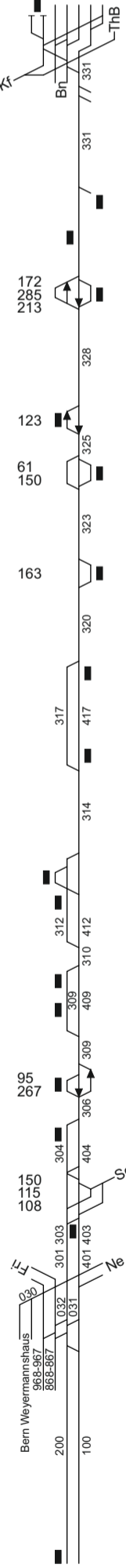
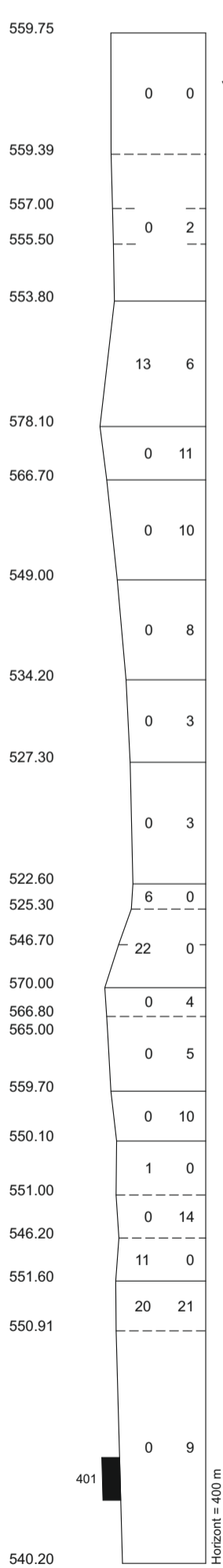

Blockstationen	Entf. von Stat. zu Stat.	Kilometerung der Bahn
Bern	0.86	97.18
Bern JKLM		96.32
Bern Weyermannshaus (Spw)	1.41	94.92
Bern Holligen	0.48	2.71
Bern Ausserholligen GBS	0.41	3.12
Bern Fischermätteli (Abzw)	0.40	3.52
Köniz	0.72	5.00
Liebefeld	1.47	5.71
Moos	2.08	7.80
Gasel	1.08	8.87
Niederscherli	2.01	10.89
Mittelhäusern	1.94	12.82
Schwarzwasserbrücke	1.83	14.66
Lanzenhäusern	3.18	17.83
Schwarzenburg	3.04	20.87



Blockstationen	Entf. von Stat. zu Stat.	Kilometerung der Bahn
Bern	0.86	97.18
Bern JKLM		96.32
Bern Weyermannshaus (Spw)	1.41	94.92
Bern Holligen	0.48	2.71
Bern Ausserholligen GBS	0.41	3.12
Bern Fischermätteli (Abzw)	0.40	3.52
Köniz	0.72	5.00
Liebefeld	1.47	5.71
Moos	2.08	7.80
Gasel	1.08	8.87
Niederscherli	2.01	10.89
Mittelhäusern	1.94	12.82
Schwarzwasserbrücke	1.83	14.66
Lanzenhäusern	3.18	17.83
Schwarzenburg	3.04	20.87

Bern Holligen
Bern Steigerhubel (Abzw)
Bern Weyermannshaus

Bern JKLM

Bern

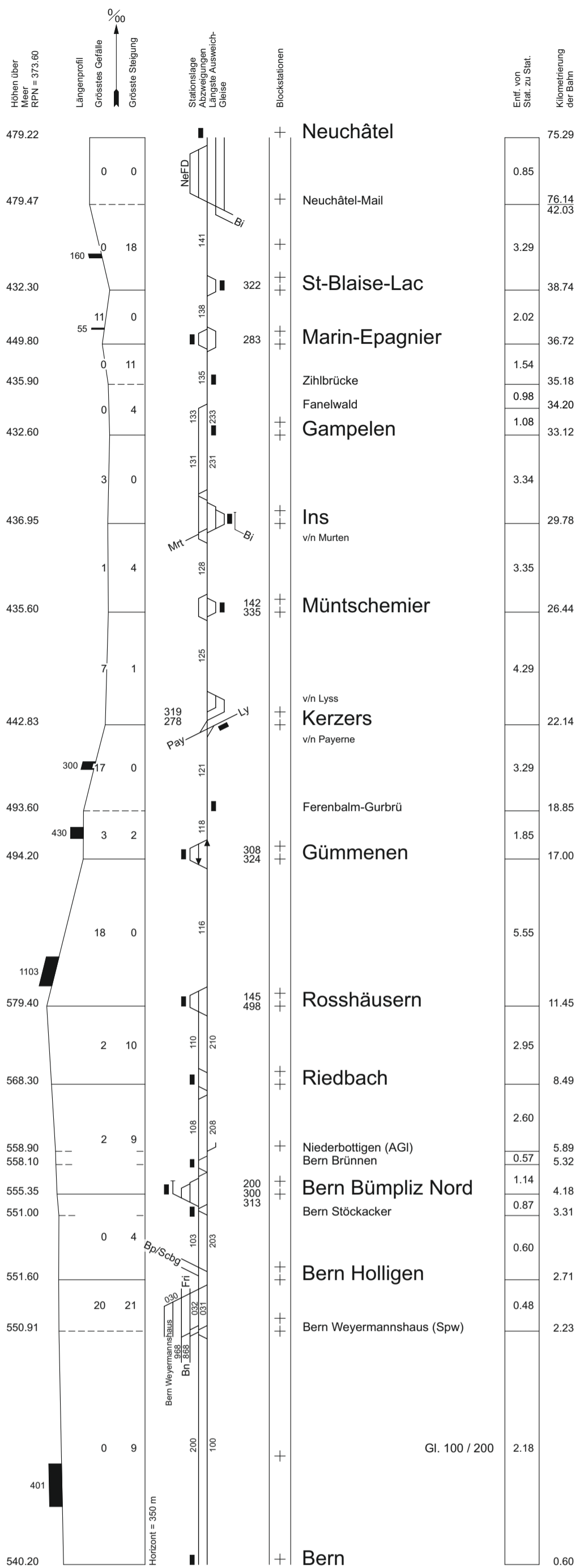

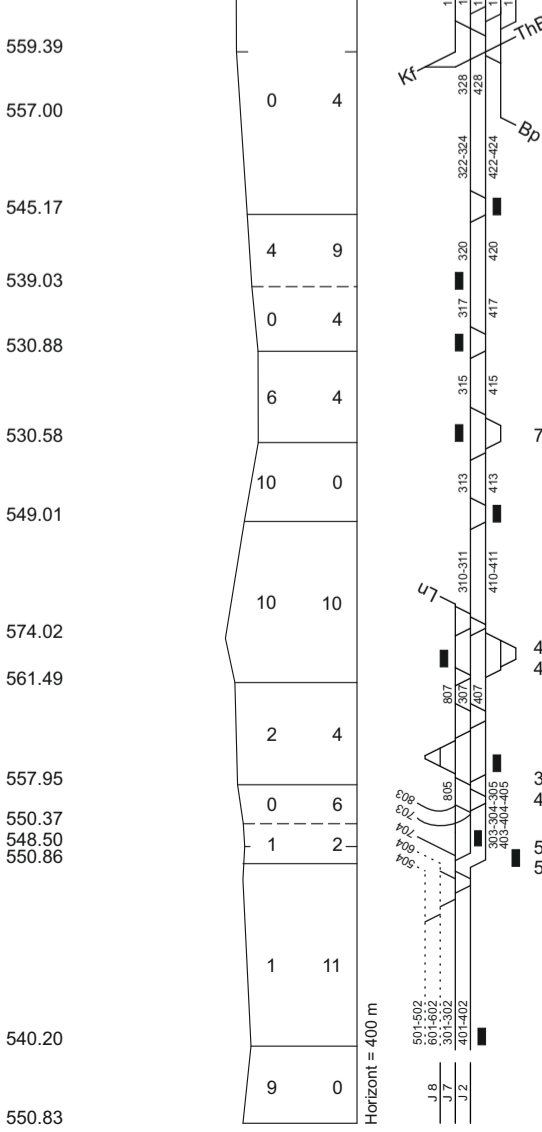
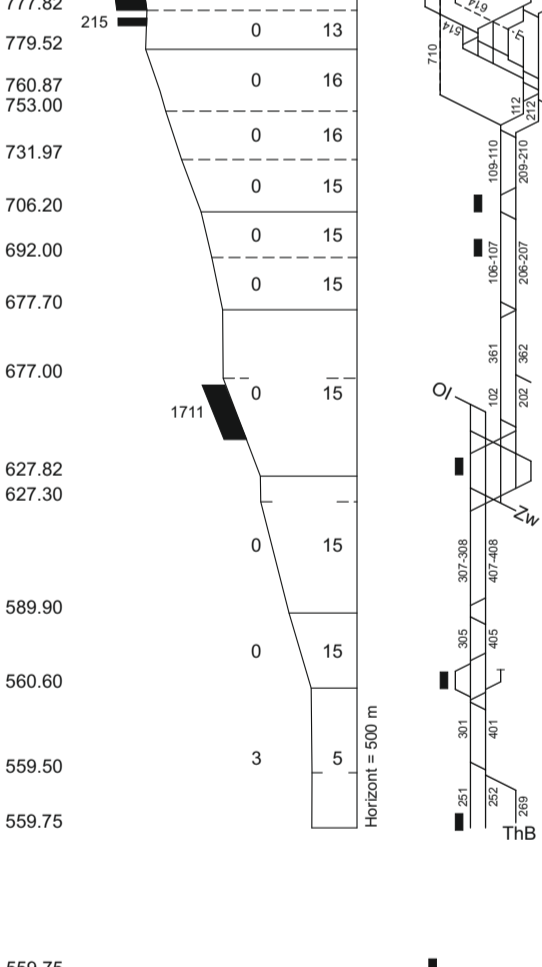
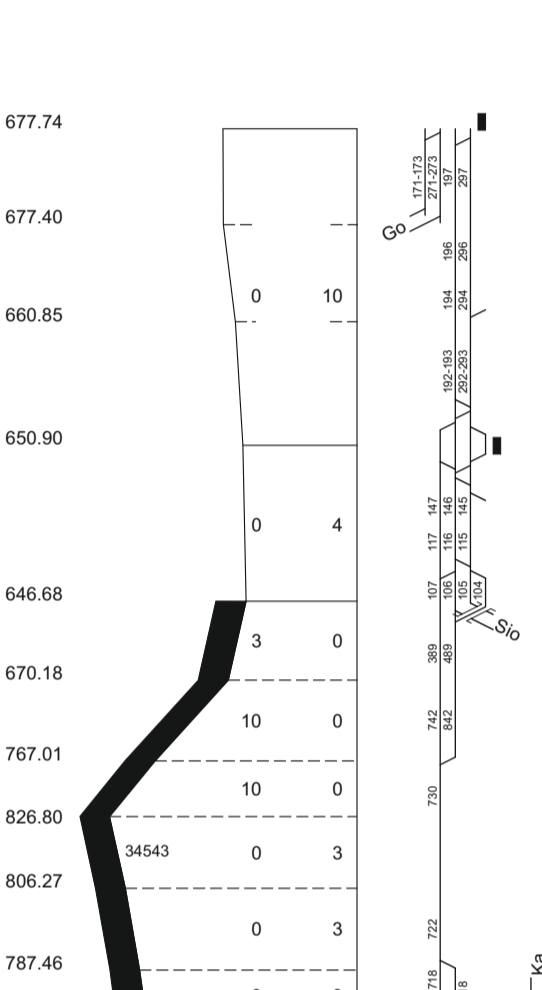
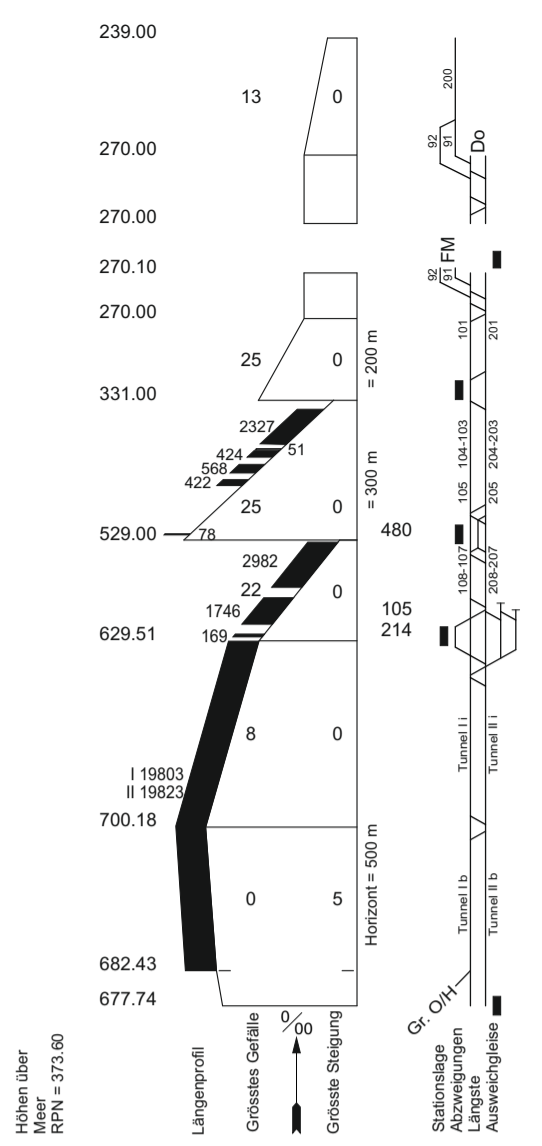

Blockstationen	Entf. von Stat. zu Stat.	Kilometerleistung der Bahn
Domodossola II	5.22	191.34
Domodossola FM	1.08	186.12
Domodossola (bif)		185.04
Domodossola	1.24	186.28
Domodossola (bif)	2.59	185.04
Preglia		182.45
Rio Rido		
Mognatta	8.71	
Varzo		173.75
Galleria elicoïdale	6.27	
Iselle di Trasquera		167.48
	11.13	
Staz. della Galleria Sempione		156.35
	9.20	
Brig Tunnel		147.15
Brig	1.60	145.55
Brig		73.81
	Gl. 173 / 273	0.30
Brig Lötschberg (Abzw)		73.51
Brig		145.55
Brig Lötschberg (Abzw)	0.30	
Gliser Grund	3.81	
Gamsen SBB		141.44
	4.71	
Visp		136.73
	3.32	135.90 135.89
St. German (Abzw)		133.40 50.12
	6.28	
Lötschen		43.84
	8.62	
Ferden (Spw)		35.22
	13.20	
Mitholz		22.02
	6.26	
Adelrain (Abzw)		15.76
Frutigen Nordportal (Abzw)	1.12	
Frutigen	1.27	14.65 (14.26) (14.41) 13.54
Winklen (Spw)	1.51	12.03
Wengi (AGI)	0.16	11.87
	4.54	
Wengi-Ey (Abzw)	10.11 (9.90) (9.97)	10.28 (9.97) (9.97)
Reichenbach i/K.	1.93	8.29
Mülönen	1.44	6.85
Heustrich-Emdthal	1.68	5.16
Hondrich Süd (AGI)	2.17	2.99 2.90
	3.00	0.00 -0.106 9.78
Spiez	0.89	8.90
Spiez (Abzw)		
	3.46	
Einigen		5.44
	2.33	
Gwatt		3.10
	2.62	
Thun Schadau (Abzw)		0.49 0.06
Thun	1.00	137.59 137.02
Thun		137.02
Thun (Abzw)	0.87	136.15
Lerchenfeld	1.52	134.63
	3.53	
Uttigen		131.10
Kiesen	2.79	128.30
	2.57	
Wichtrach		125.73
	3.60	
Münsingen		122.13
	3.09	
Rubigen		119.04
Allmendingen	3.67	
Gümligen Süd (Abzw)		115.37
Gümligen	1.41	113.96
Dennigkofen	3.19	
Ostermündigen		110.77
Wankdorf (Abzw)	1.28	109.48
Bern Wankdorf	0.51	108.97
Bern Wylerefeld	0.39	108.58 103.33
	2.80	
Lorraine		
Bern		106.16 97.18
	0.86	
Bern JKLM		96.32

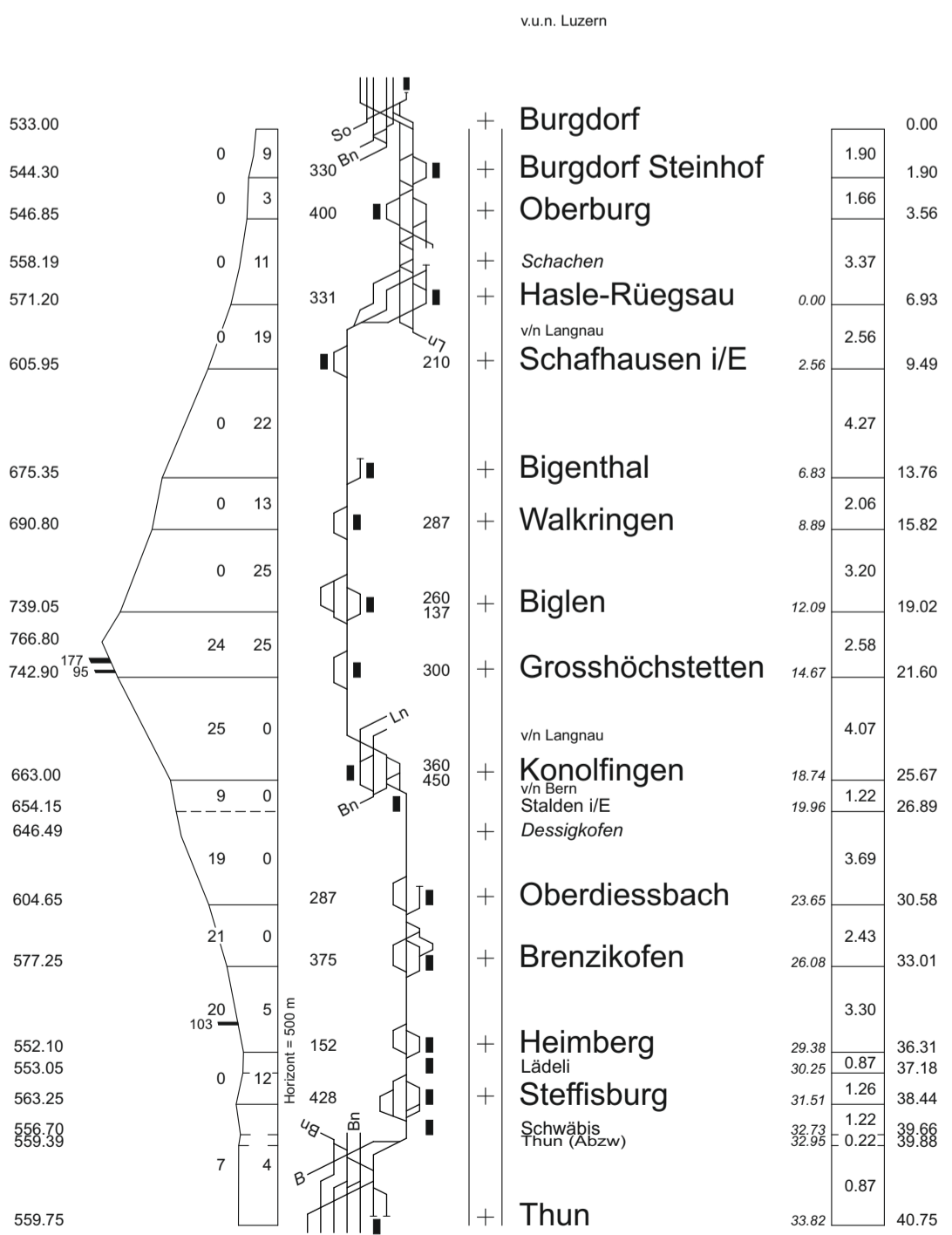
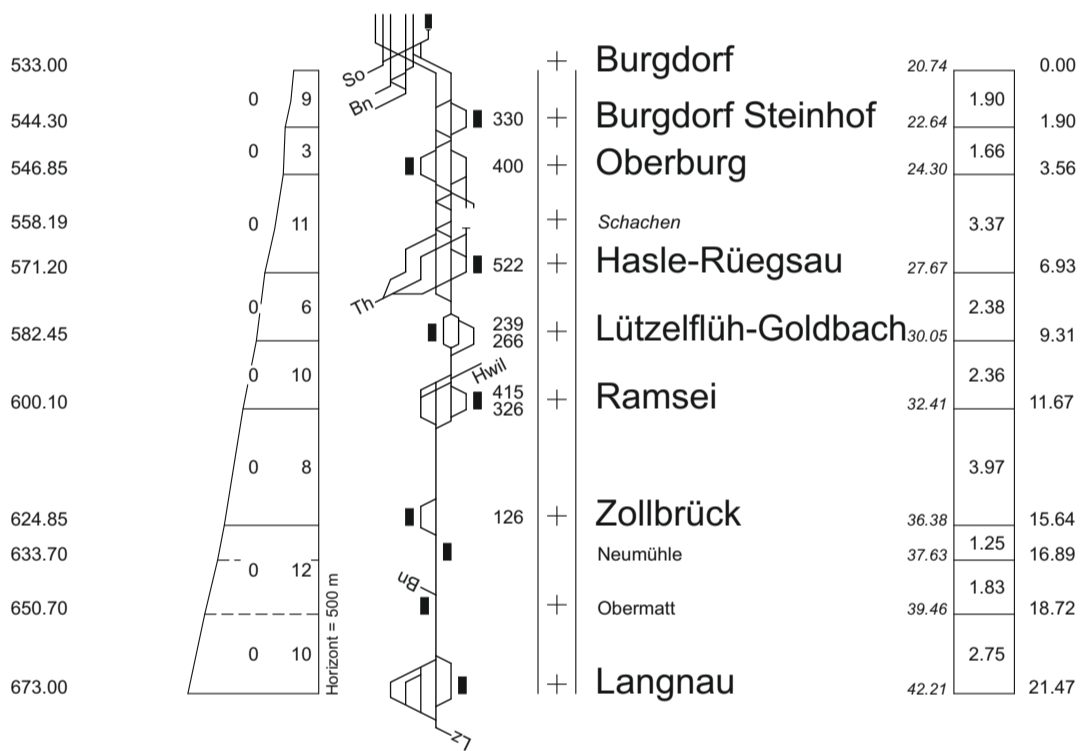
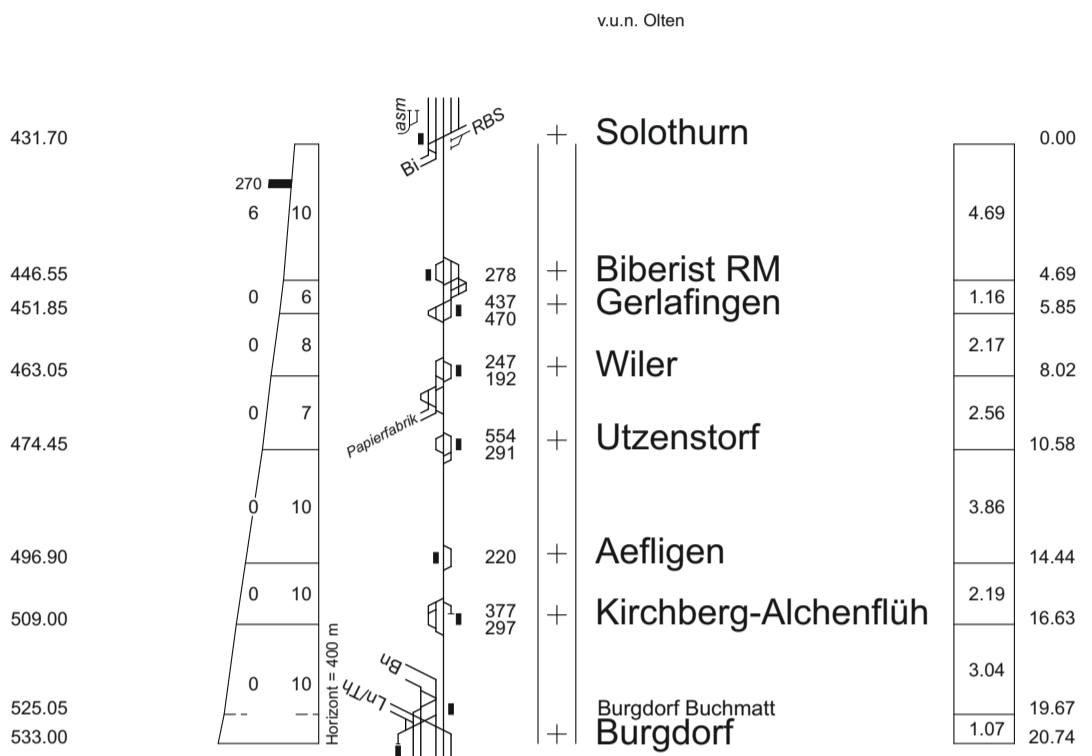
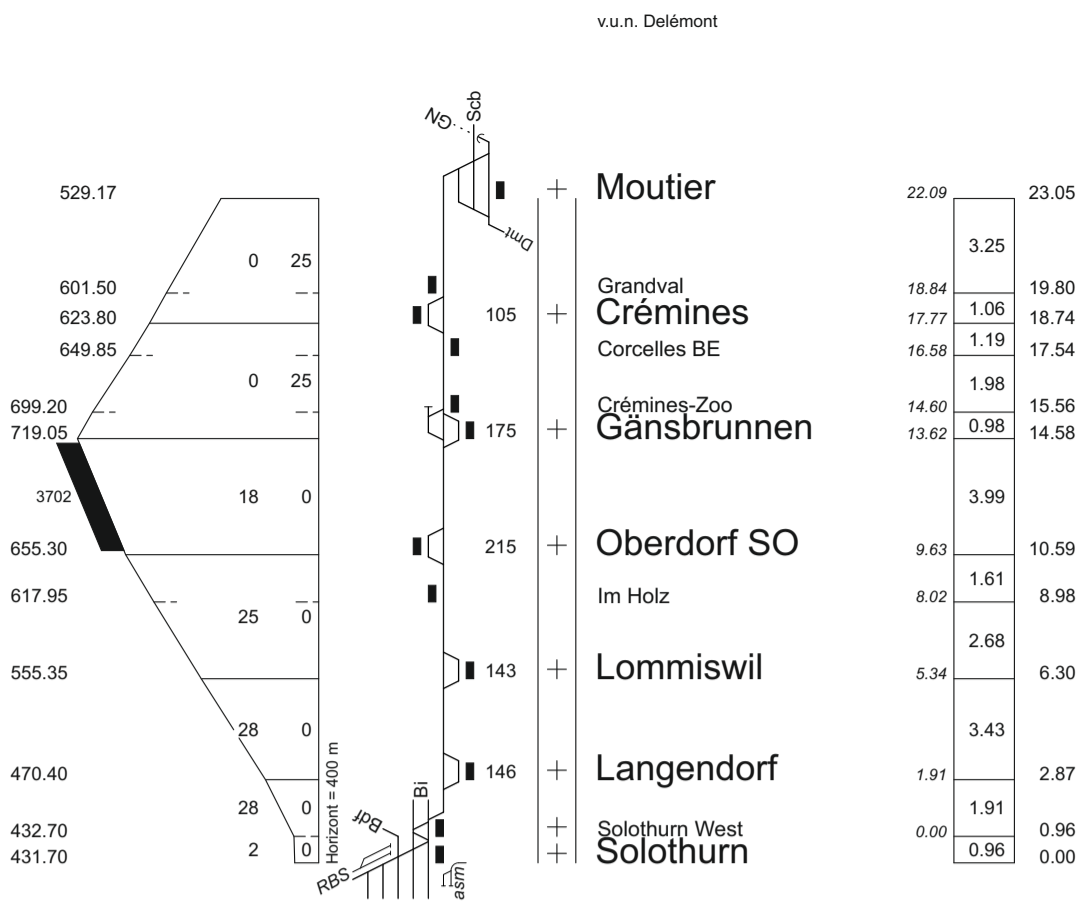

Höhen über Meer
RPN = 373.60

Längenprofil
Grösstes Gefälle
Grösste Steigung

Stationslage
Abzweigungen
Längste Ausweich-
Gleise

Blockstationen

Thun (Abzw)

Thun

Thun Schadau (Abzw)

Entf. von Stat. zu Stat.

Kilometerung der Bahn

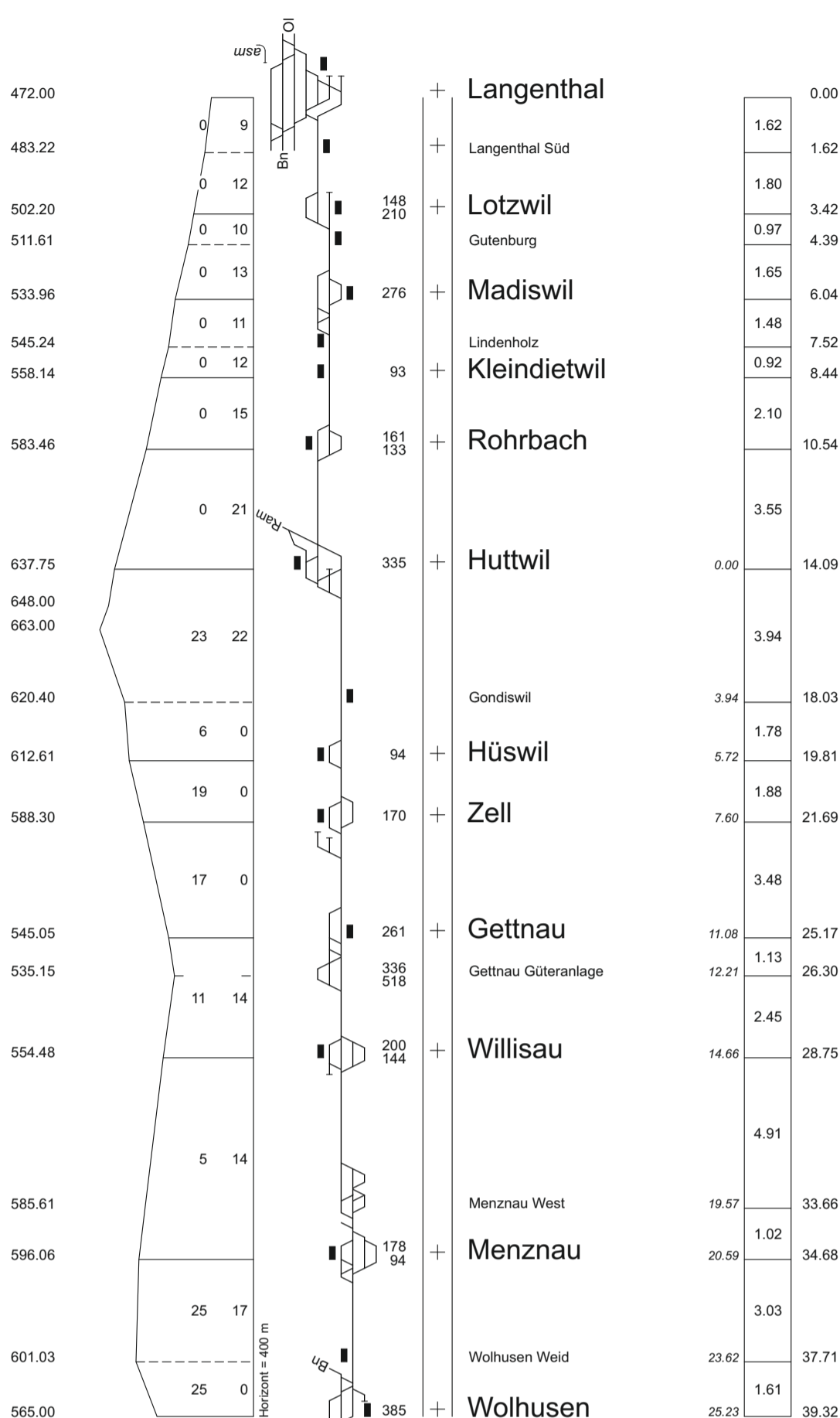

v.u.n. Olten
v.u.n. Bern

Höhen über Meer
RPN = 373.60

Längenprofil
Grösstes Gefälle
Grösste Steigung

Stationslage
Abzweigungen
Längste Ausweich-Gleise

Blockstationen

Entf. von Stat. zu Stat.
Kilometrierung der Bahn

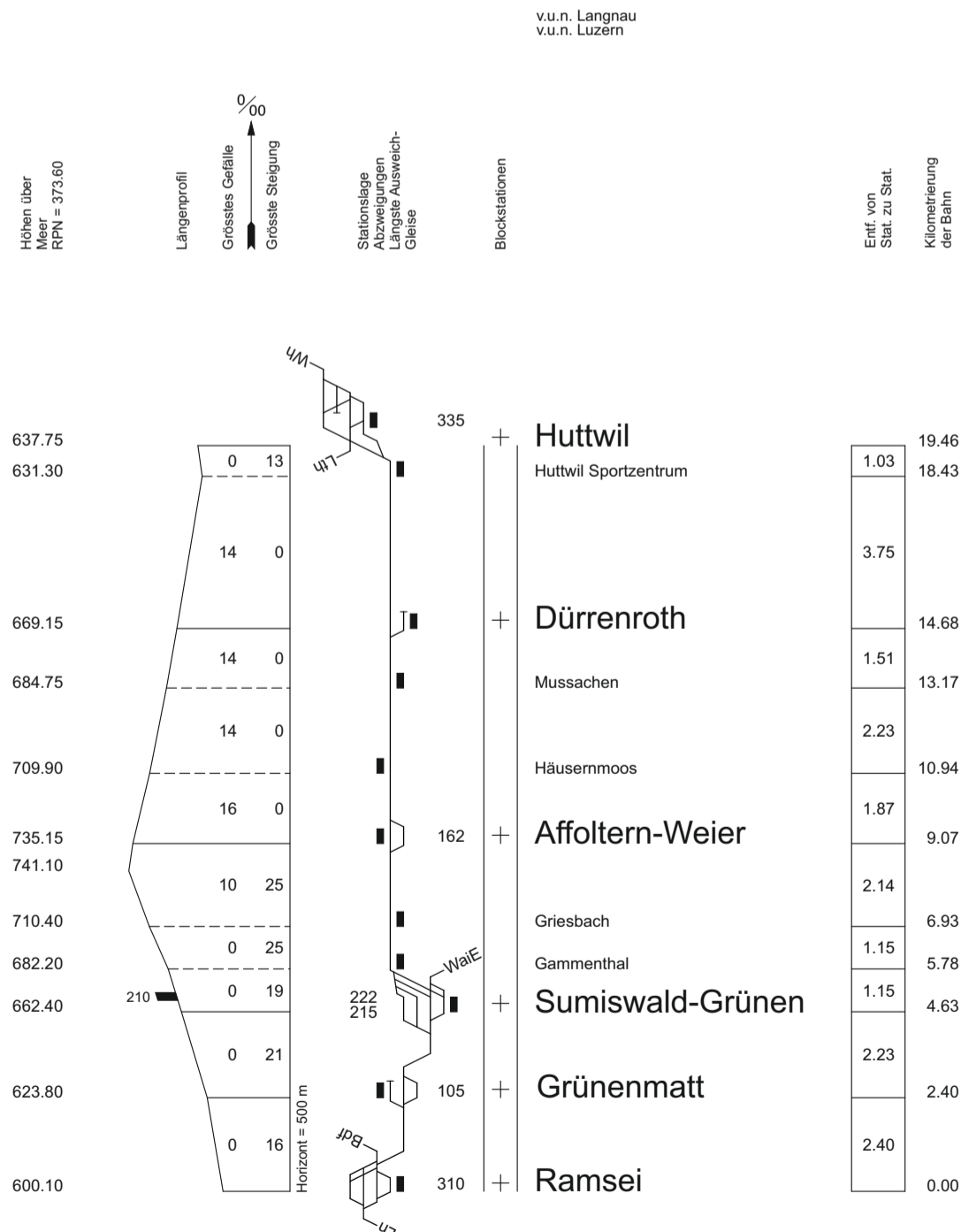

v.u.n. Langnau
v.u.n. Luzern

v.u.n. Burgdorf
v.u.n. Langnau

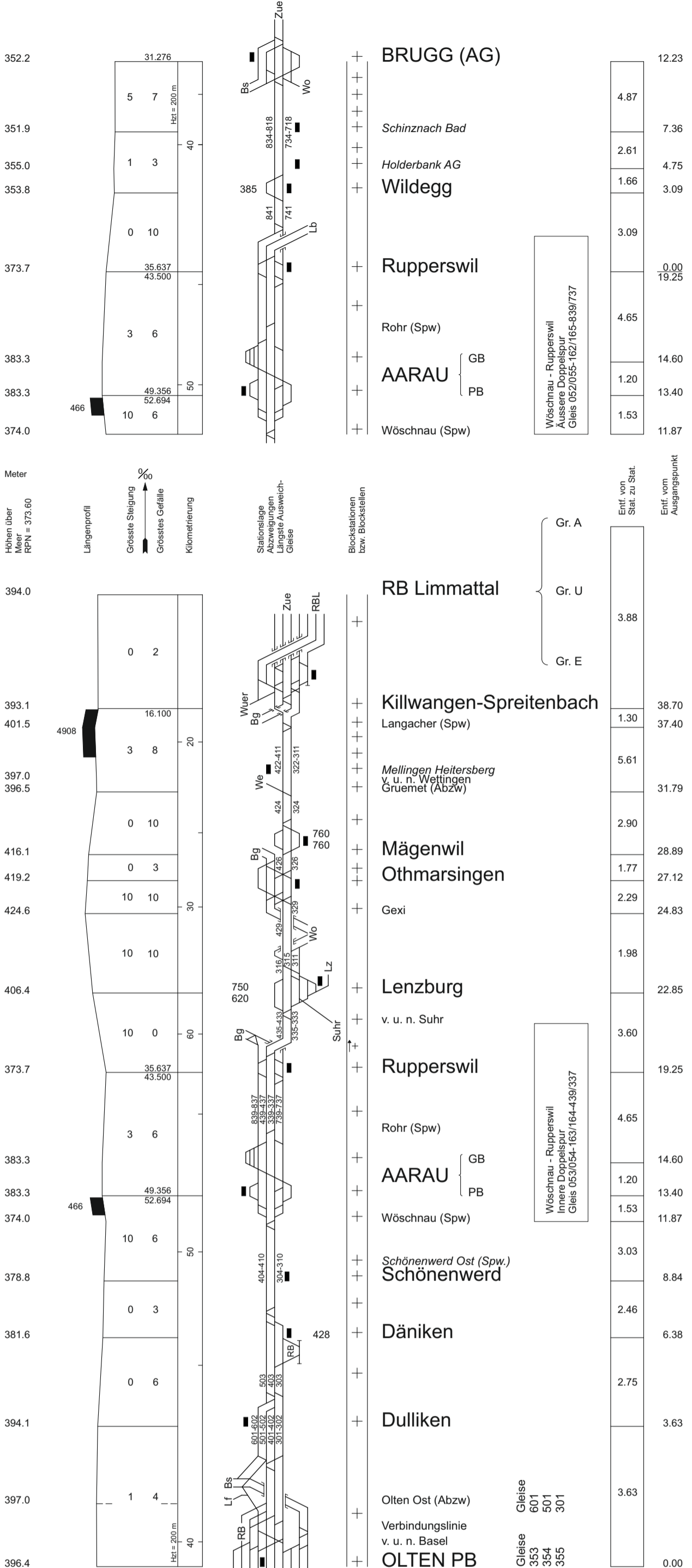

Höhen über Meer RPN = 373.60	Meter	352.2	351.9	355.0	353.8	373.7	383.3	383.3	374.0	394.0	393.1	401.5	397.0	396.5	416.1	419.2	424.6	406.4	373.7	383.3	383.3	374.0	378.8	381.6	394.1	397.0	396.4		
Längenprofil	Grösste Steigung Grösstes Gefälle	5 7	1 3	0 10	3 6	10 6	10 6	10 0	3 6	10 0	0 3	3 8	0 10	0 10	10 10	0 3	10 10	10 0	10 0	3 6	10 6	10 6	0 3	0 6	1 4	0 6	0 6		
Kilometrierung		31.276	40	35.637	43.500	49.356	52.694	50	50	39.305	20	16.100	30	40	30	40	30	40	60	60	40	40	40	40	40	40	40	40	
Stationen Abzweigungen Längste Ausweich- Gleise				841	834-818 734-718	385	841 741	428	750 620	601-602 501-502 401-402 301-302		422-411	424	324	428	428	329	760	760	838-837 438-437 338-337 738-737									
Blockstationen bzw. Blockstellen																													
Brugg (AG)																													
Schinznach Bad																													
Holderbank AG																													
Wildeg																													
Rapperswil																													
Rohr (Spw)																													
AARAU																													
Wöschnau (Spw)																													
RB Limmattal																													
Killwangen-Spreitenbach																													
Langacher (Spw)																													
Mellingen Heitersberg v. u. n. Wettingen Gruemet (Abzw)																													
Mägenwil																													
Othmarsingen																													
Gexi																													
Lenzburg																													
v. u. n. Suhr																													
Rapperswil																													
Rohr (Spw)																													
AARAU																													
Wöschnau (Spw)																													
Schönenwerd Ost (Spw.)																													
Schönenwerd																													
Däniken																													
Dulliken																													
Olten Ost (Abzw)																													
Verbindungsline v. u. n. Basel																													
OLTEN PB																													
Gl. 401																													
Olten Ost (Abzw)																													
Olten																													



© Infrastruktur - Fahrplan und Netzdesign, Bern



SBB

I-FN-FPA-RME

Ausgabe von 14.12.2014

OLTEN PB

v. u. n. Luzern/Bern via ABO
v. u. n. Aarau

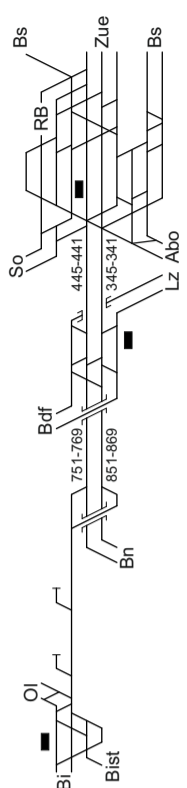

Station	Entf. von Stat. zu Stat. (km)	Entf. vom Ausgangspunkt (km)
OLTEN PB		37.30
Rothrist	5.86	31.44
Wanzwil (Abzw)	19.39	12.05
Inkwil (Verzw)	6.56	5.49
Subingen	2.45	3.04
Derendingen	3.04	0.00
SOLOTHURN		

Gleise
351
352

v. u. n. Aarau
v. u. n. Basel

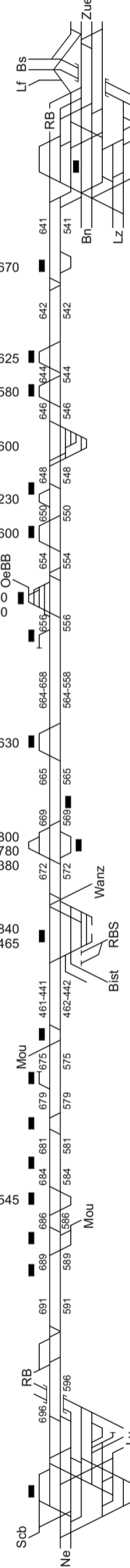

Station	Entf. von Stat. zu Stat. (km)	Entf. vom Ausgangspunkt (km)
OLTEN		
Olten Hammer	1.33	60.07
Wangen bei Olten	2.42	58.74
Hägendorf	2.26	56.32
Härkingen Paketpost	2.14	54.06
Egerkingen	1.66	51.92
Oberbuchsiten	2.32	50.26
v. u. n. Balsthal	5.21	47.94
Oensingen	1.98	42.73
Niederbipp	5.69	40.75
Wangen a.d. Aare	3.30	35.06
Deitingen	2.75	31.76
Luterbach-Attisholz	3.46	29.01
v. u. n. Wanzwil	0.96	25.55
SOLOTHURN		
Solothurn West v. u. n. Moutier Solothurn Allmend	0.88	24.59
Bellach	2.00	21.71
Selzach	3.04	18.67
Bettlach	2.19	16.48
Grenchen Süd v. u. n. Moutier	2.39	14.09
Lengnau	2.72	11.37
Pieterlen	2.22	9.15
Biel/Bienne Bözingenfeld/ Champs-de-Boujean	1.98	7.17
Biel Mett (Abzw)	1.78	5.39
Biel Mett	1.83	3.56
Biel Mett	0.44	3.12
BIEL PB	3.12	0.00

RB
PB

v. u. n. Bern
v. u. n. La Chaux-de-Fonds
v. u. n. Neuchâtel



Meter
Höhen über Meer
RPN=373.60
Längenprofil

Grösste Steigung
Grösstes Gefälle
Kilometrierung

Stationslage
Abzweigungen
Längste Ausweich-
Gleise

Blockstationen
bzw. Blockstellen

Km
Entf. von Stat. zu Stat.
Entf. vom Ausgangspunkt

34



SBB

I-FN-FPA-RME

Ausgabe von 14.12.2014

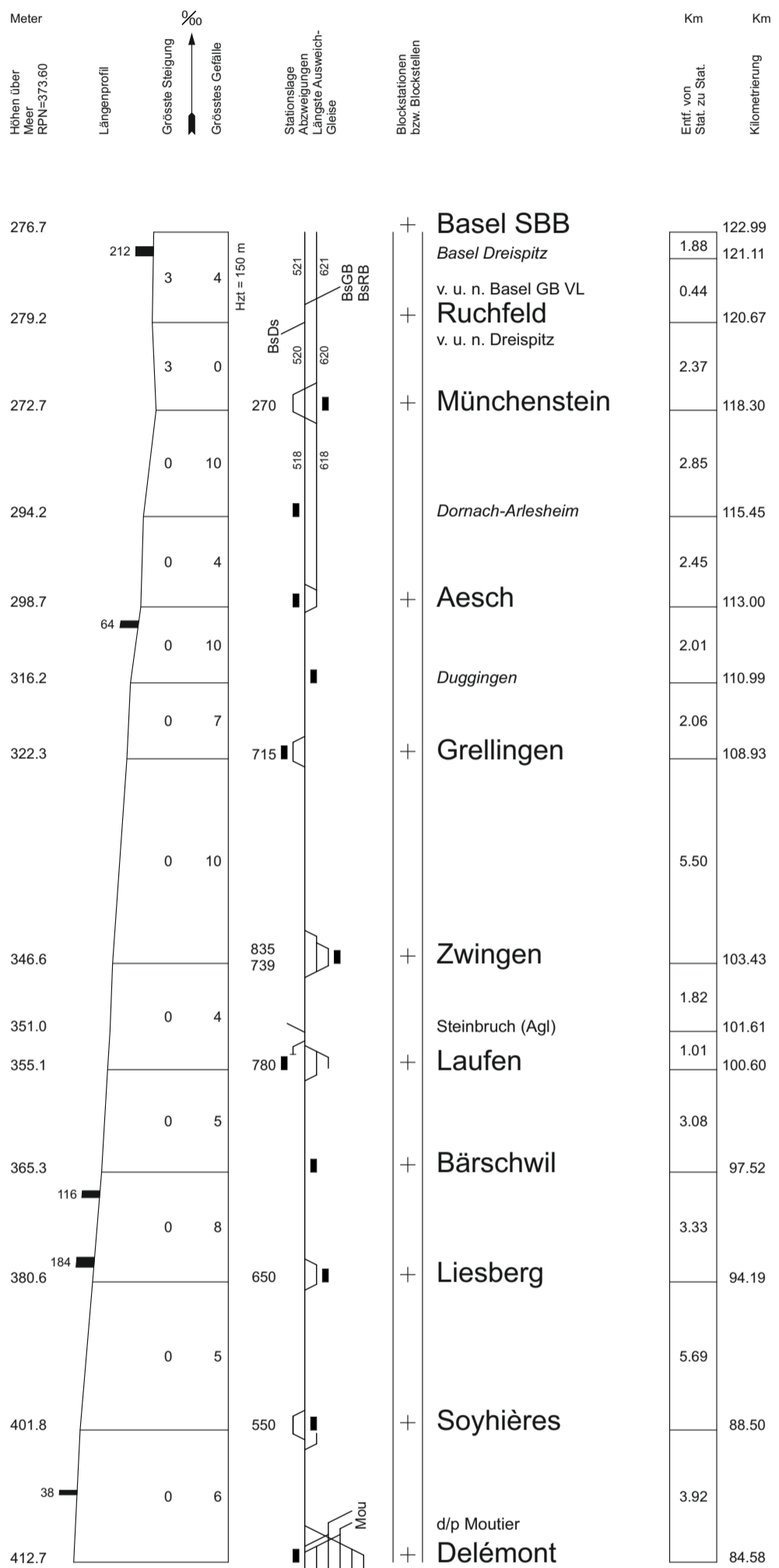

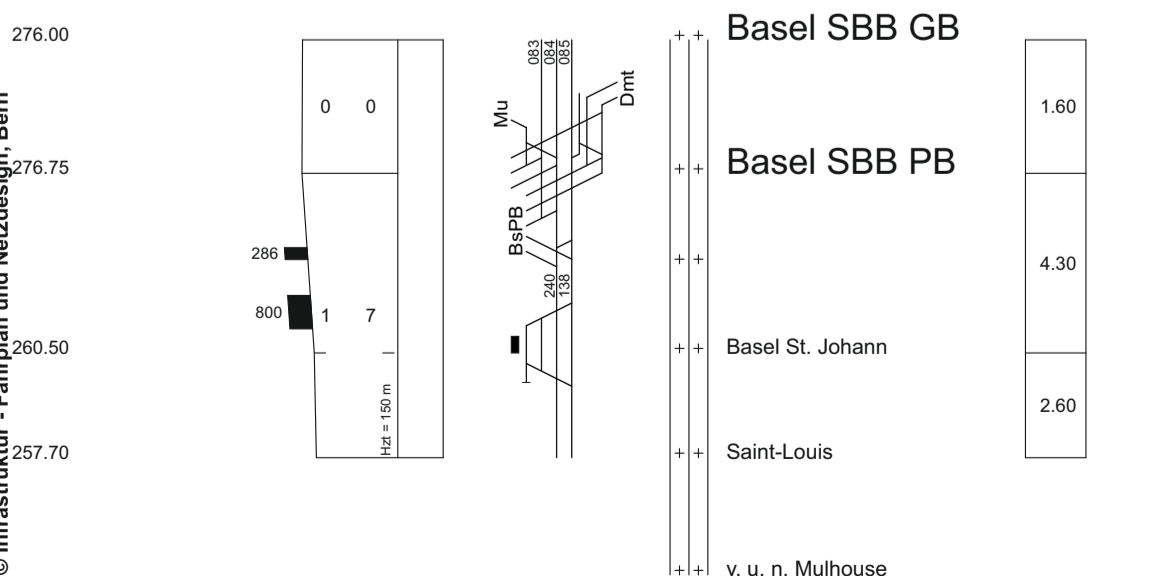
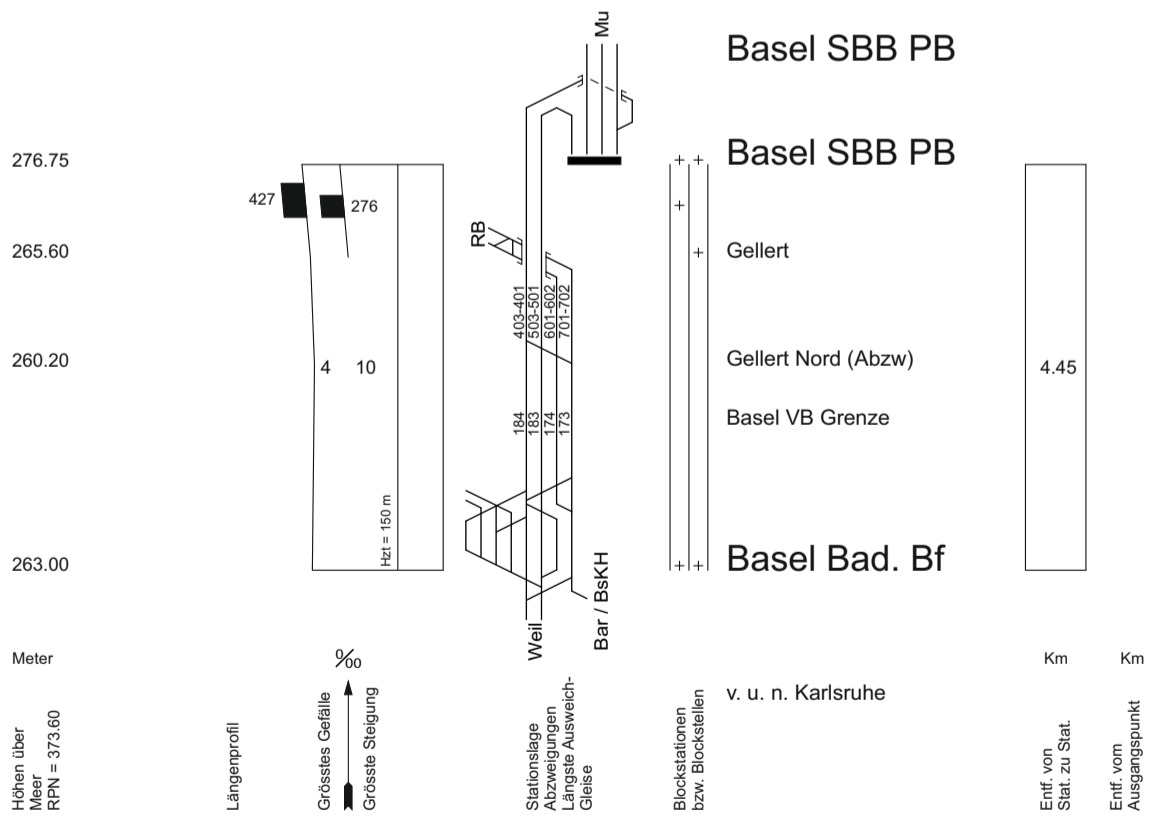
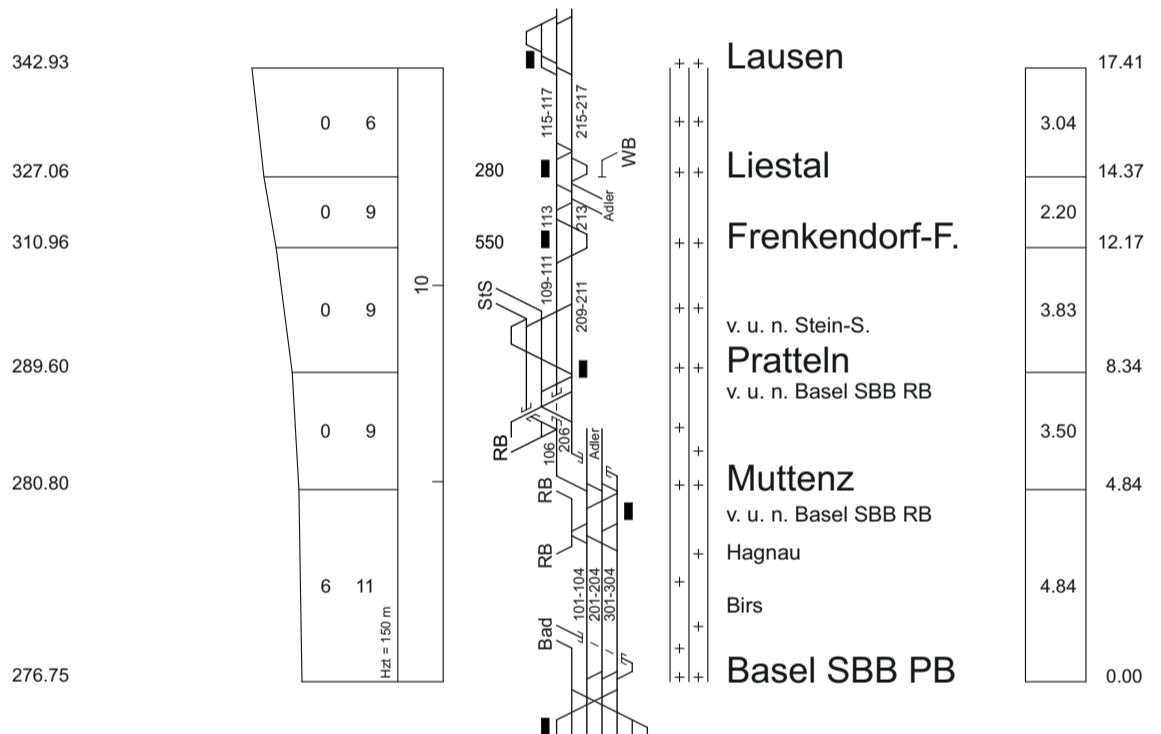
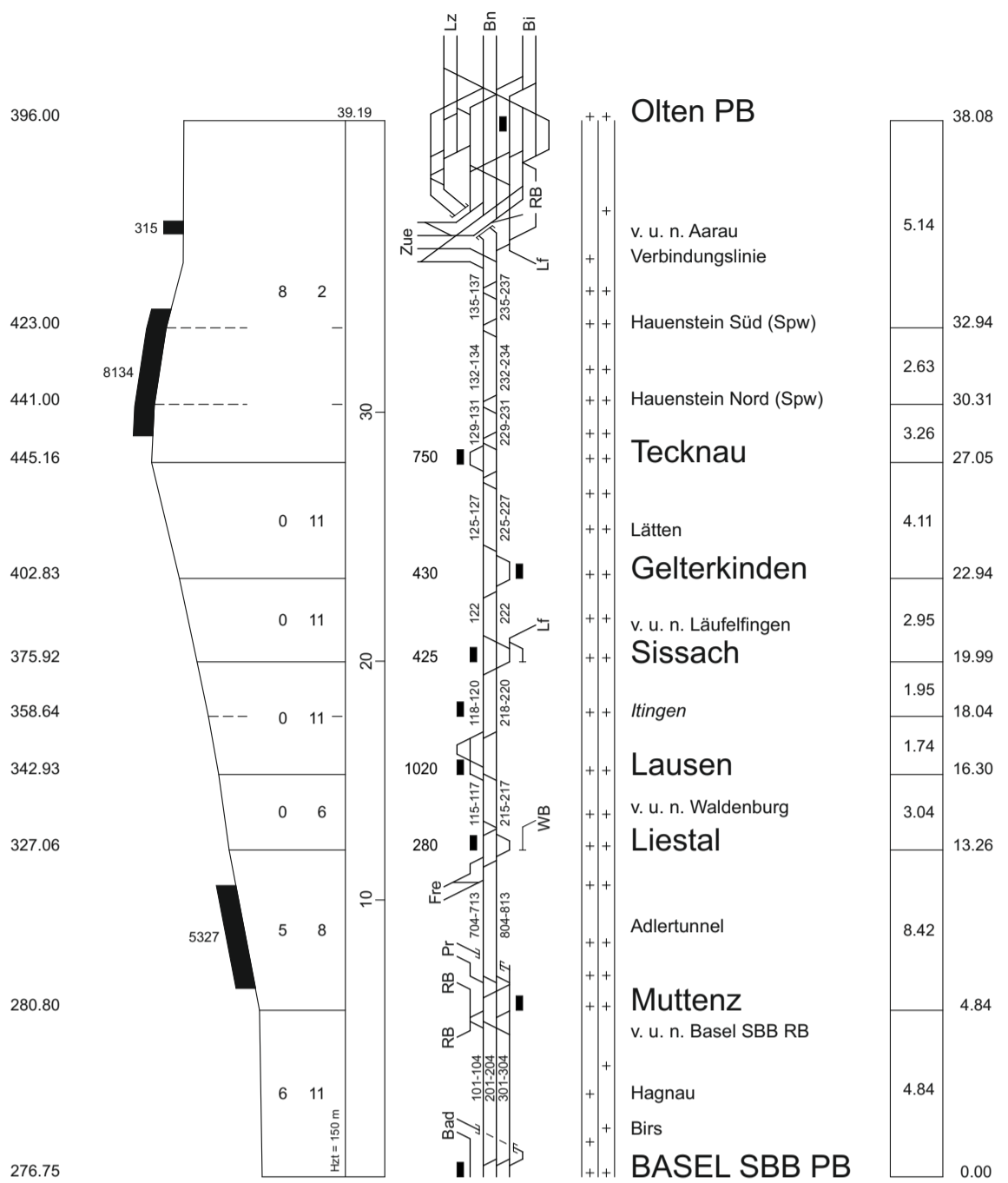

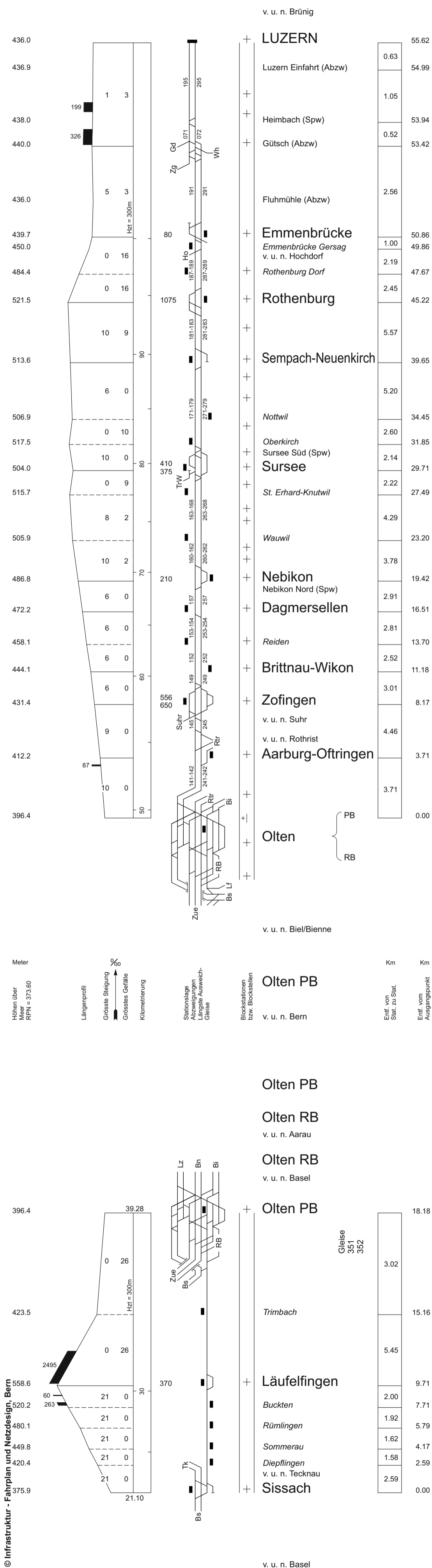

v. u. n. Brünig

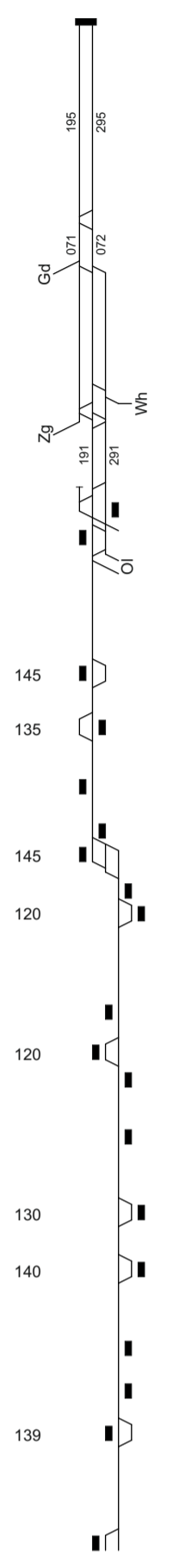
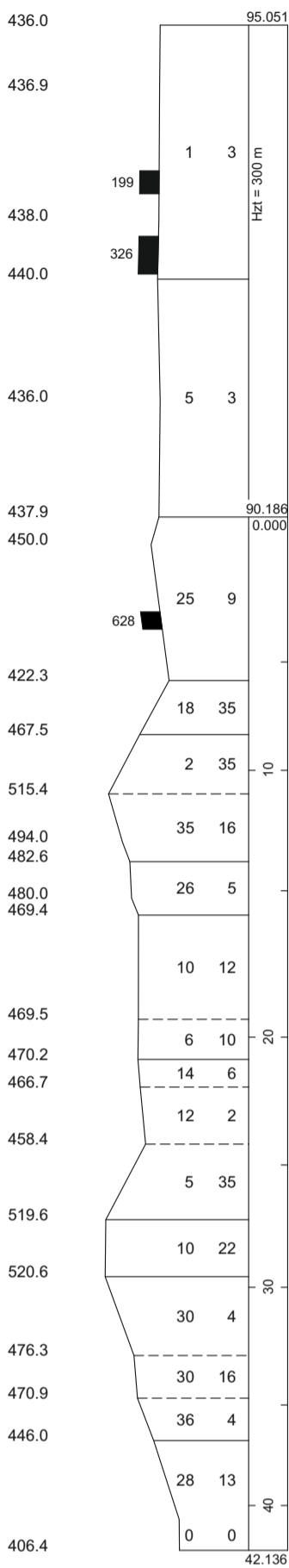

Station	Entf. von Stat. zu Stat. (km)	Entf. vom Ausgangspunkt (km)
LUZERN	0.63	46.91
Luzern Einfahrt (Abzw)	0.63	46.28
Heimbach (Spw)	1.05	45.23
Gütsch (Abzw)	0.52	44.71
Fluhmühle (Abzw)	2.56	42.15
Emmenbrücke	1.00	41.15
Emmenbrücke Gersag v. u. n. Olten	4.86	36.29
Waldibrücke	2.72	33.57
Eschenbach	2.42	31.15
Ballwil	1.89	29.26
Hochdorf Schönau	0.84	28.42
HOCHDORF	1.63	26.79
Baldegg Kloster	0.57	26.22
Baldegg	3.44	22.78
Gelfingen	1.43	21.35
Hitzkirch	1.08	20.27
Ermensee	2.27	18.00
Mosen	3.06	14.94
BEINWIL am See	2.31	12.63
Birrwil	3.57	9.06
Boniswil	1.53	7.53
Hallwil	2.25	5.28
Seon	5.28	0.00
LENZBURG		

Meter
Höhen über Meer
RPN = 373.60

Längenprofil
Grösste Steigung
Grösstes Gefälle
Kilometrierung

Stationslage
Abzweigungen
Langste Ausweichgleise

Blockstationen
bzw. Blockstellen

Km
Entf. von Stat. zu Stat.
Entf. vom Ausgangspunkt

Rupperswil

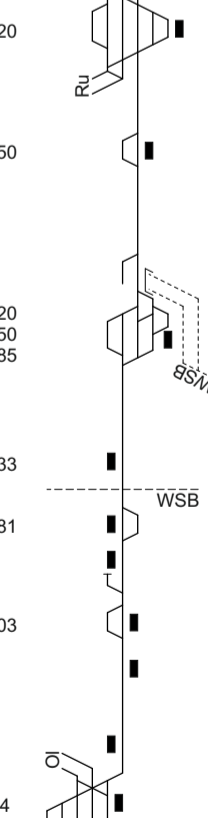
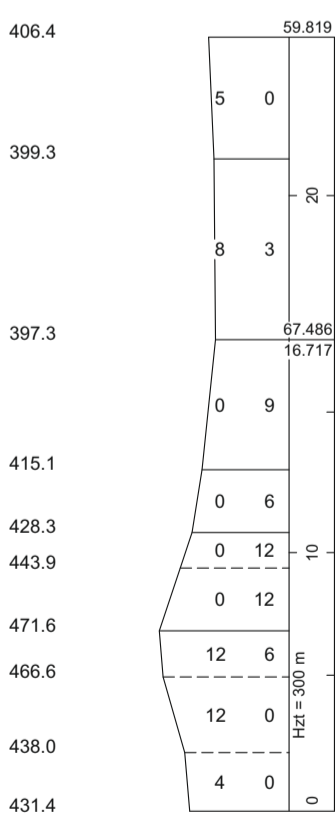

Station	Entf. von Stat. zu Stat. (km)	Entf. vom Ausgangspunkt (km)
LENZBURG	3.44	24.38
Hunzenschwil	3.20	20.94
Suhr Migros	1.02	17.74
Suhr	3.09	16.72
Oberentfelden	3.09	13.63
Kölliken	2.74	10.89
Kölliken Oberdorf	1.61	9.28
Kölliken Sondermülldeponie	2.72	6.56
Safenwil	1.62	4.94
Walterswil-Striegel	2.65	2.29
Küngoldingen v. u. n. Olten	2.29	0.00
ZOFINGEN		

v. u. n. Luzern

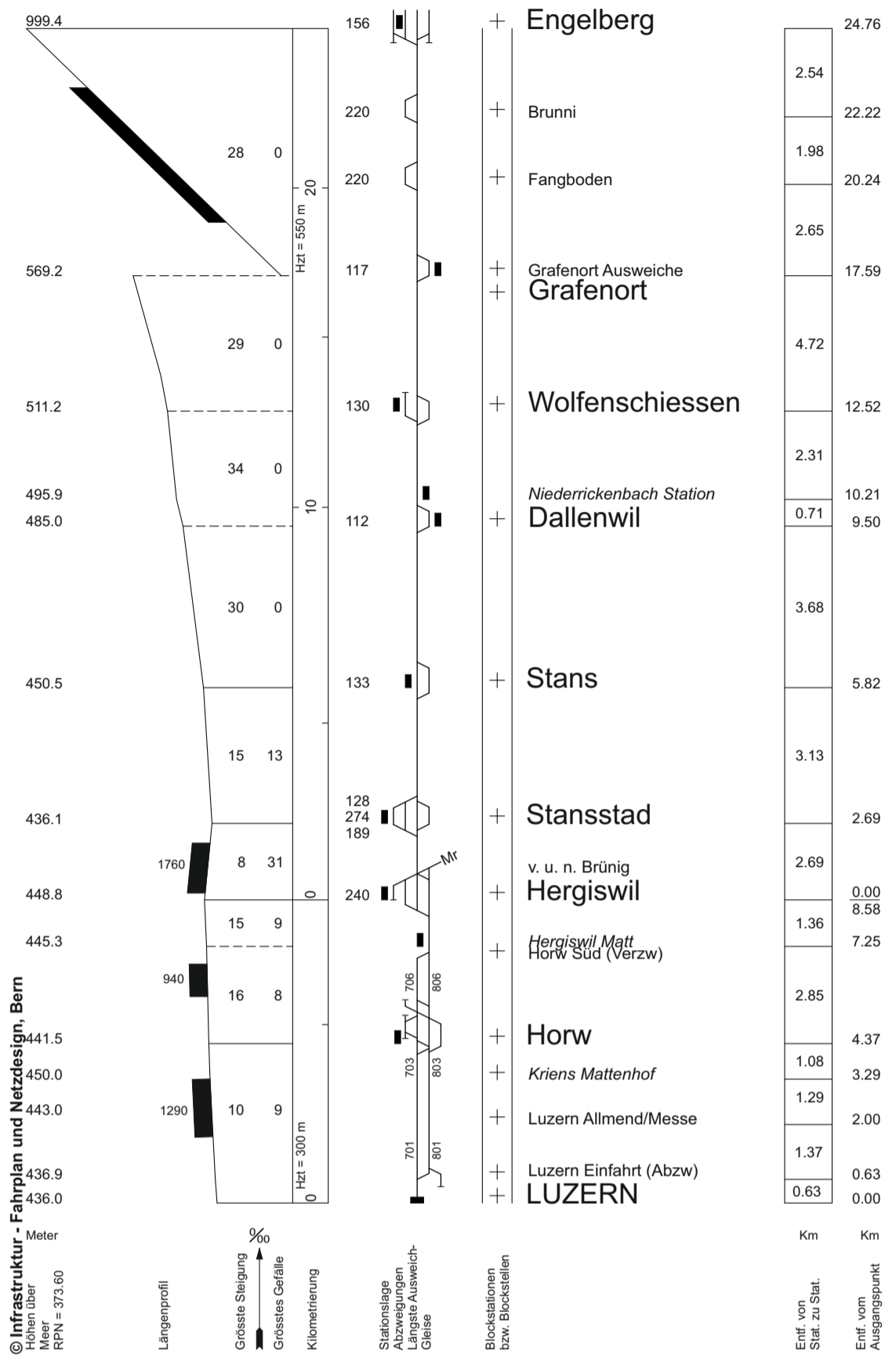

45



Die Zentralbahn.

I-FN-FPA-RME

Ausgabe von 14.12.2014

v. u. n. Zweilütschinen

v. u. n. Interlaken West

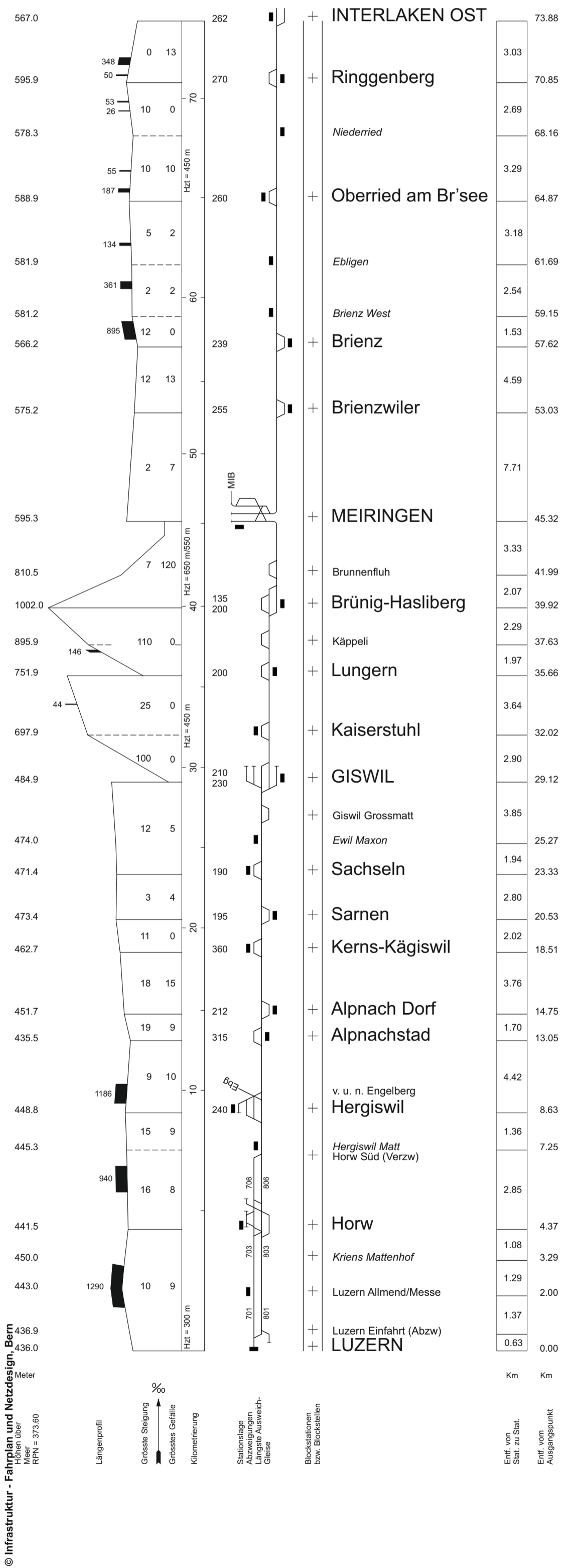

© Infrastruktur - Fahrplan und Netzdesign, Bern

Höhen über Meer
RPN = 373.60

Meter

Längenprofil
Grösste Steigung
Grösstes Gefälle
Kilometrierung

Stationslage
Abzweigungen
Längste Ausweich-
gleise
Blockstationen
bzw. Blockstellen

Entf. von Stat. zu Stat.
Entf. vom Ausgangspunkt

Km
Km

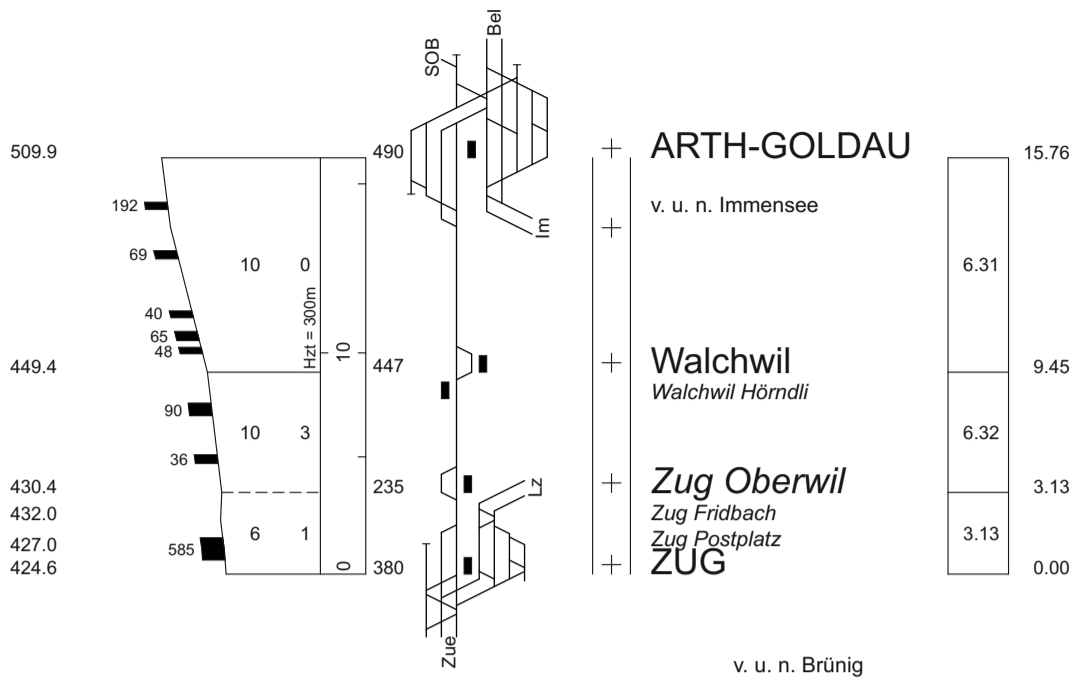

LUZERN

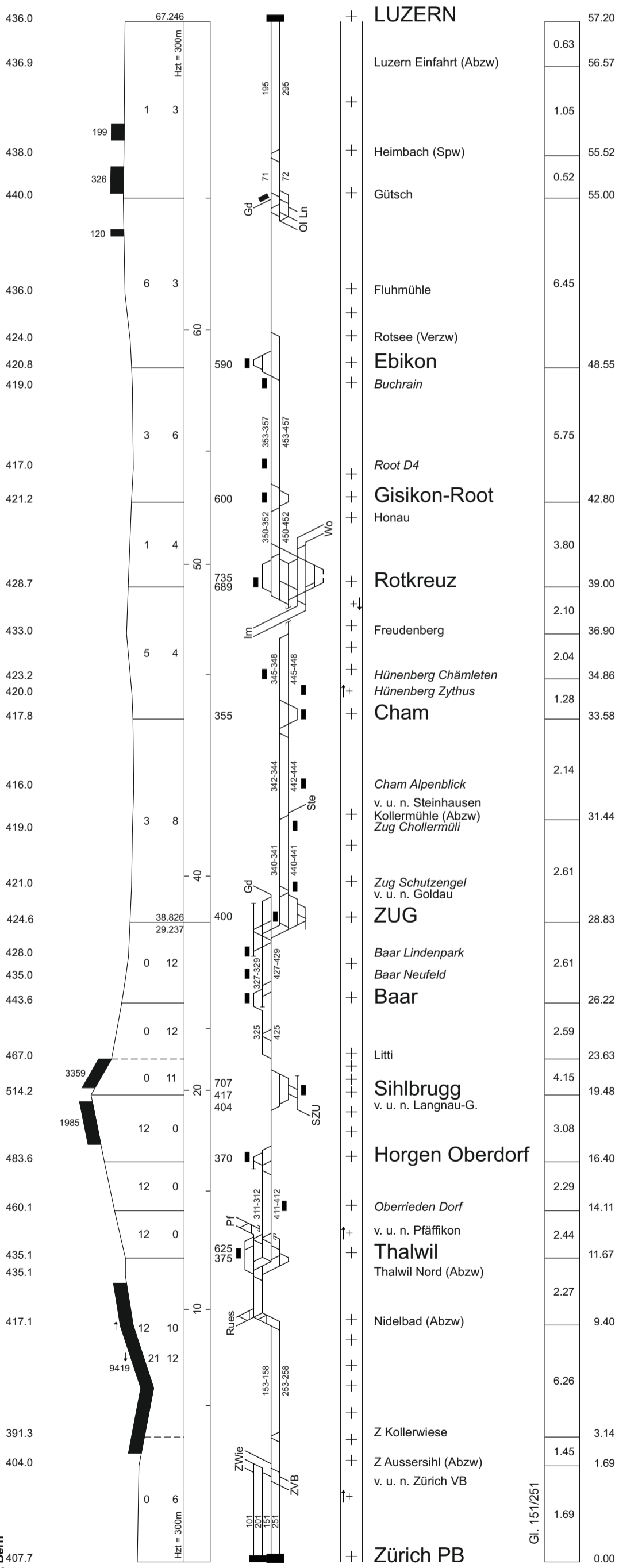

© Infrastruktur - Fahrplan und Netzdesign, Bern
 Höhen über Meer = 373.60
 RPN = 373.60

Längenprofil
 Grösste Steigung
 Grösstes Gefälle
 Klimetrierung

Stationslage
 Abzweigungen
 Längste Ausweichgleise

Blockstationen
 bzw. Blockstellen

Entf. von Stat. zu Stat.
 Entf. vom Ausgangspunkt

Zch Aussersihl

Zch Vorbahnhof

v. u. n. Olten

+ Pratteln

v. u. n. Schweizerhalle

+ Basel RB Gr E

+ Basel RB Gr F
v. u. n Gr A

+ Basel RB Gr G

Nordkopf

+ Gellert

Gellert Nord (Abzw)

+ Basel Bad. Bf.

+ Weil (Rhein)

+ Basel Bad. Rbf.

+ Basel Bad. Bf.

+ Basel Bad Rbf Kleinh. Abzw.

+ Basel Bad. Rbf.

+ Basel Bad. Bf.

+ Basel Bad Rbf Kleinh. Abzw.

+ Basel Kleinh. Hafen

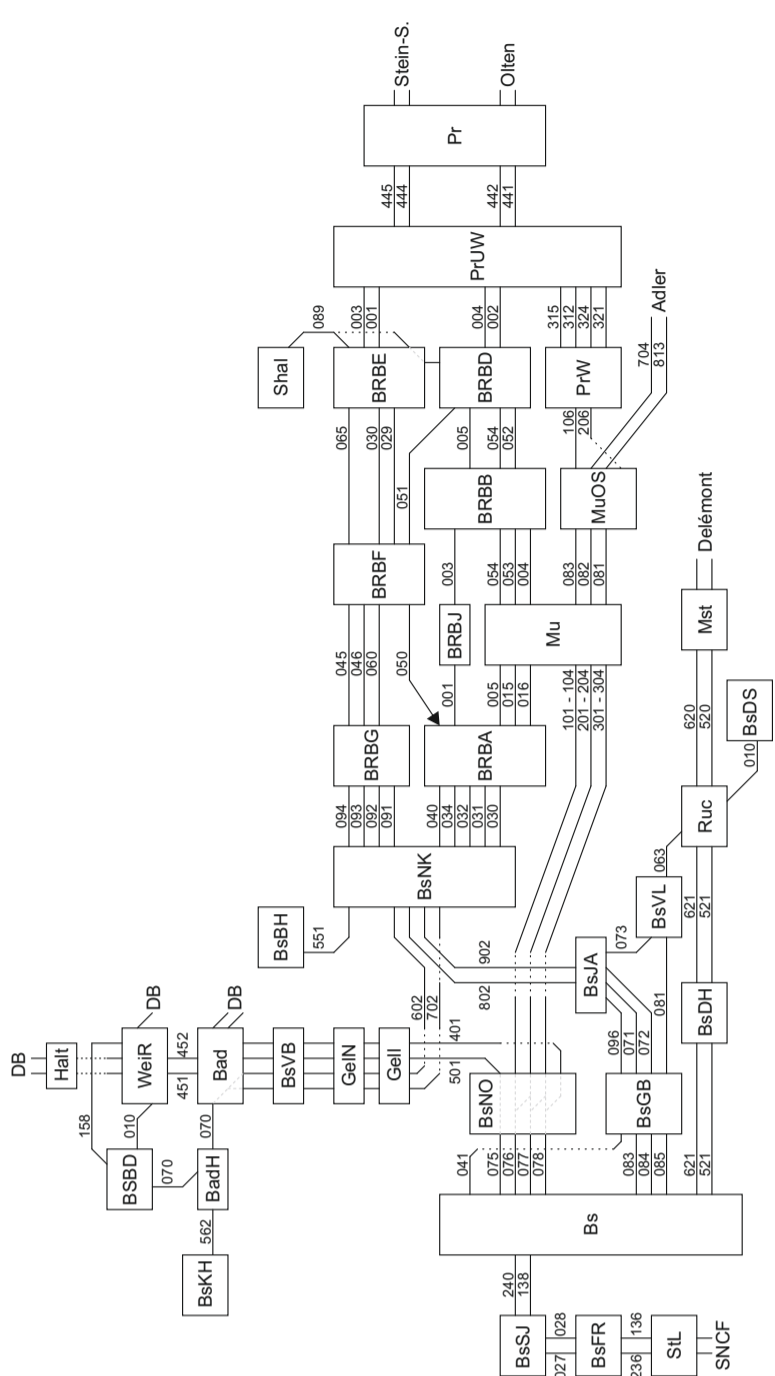

v. u. n. Stein-S.

+ Pratteln

+ Basel RB Gr D

Basel RB Gr B

+ Muttenz

+ Basel RB Gr A

Nordkopf

Basel St. Jakob

+ Basel SBB GB
v. u. n. Basel SBB (GI 041)

+ Basel SBB PB

+ Basel St. Johann

+ Saint-Louis

+ Basel RB Gr A

v. u. n. Gr G

Nordkopf

+ Birsfelden Hafen

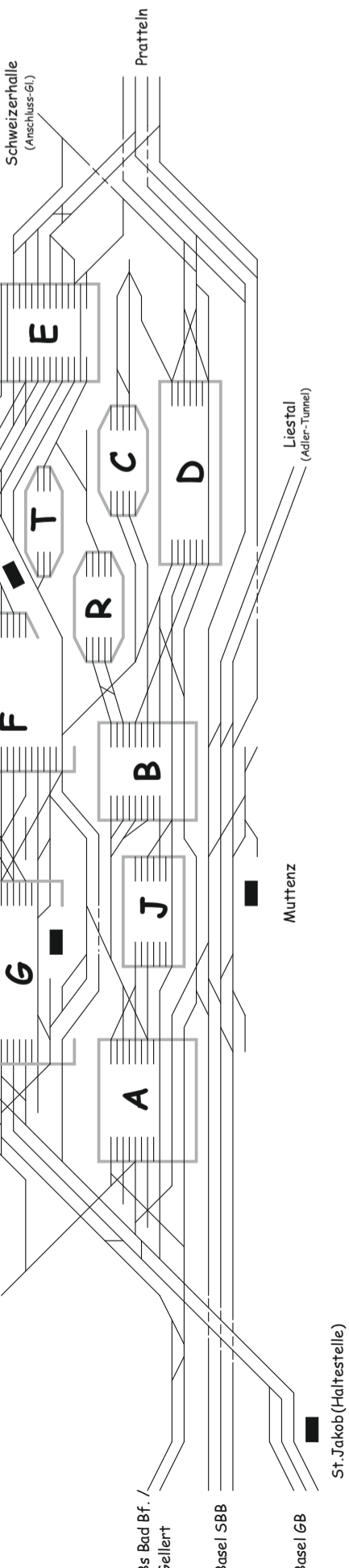

v. u. n. Zürich

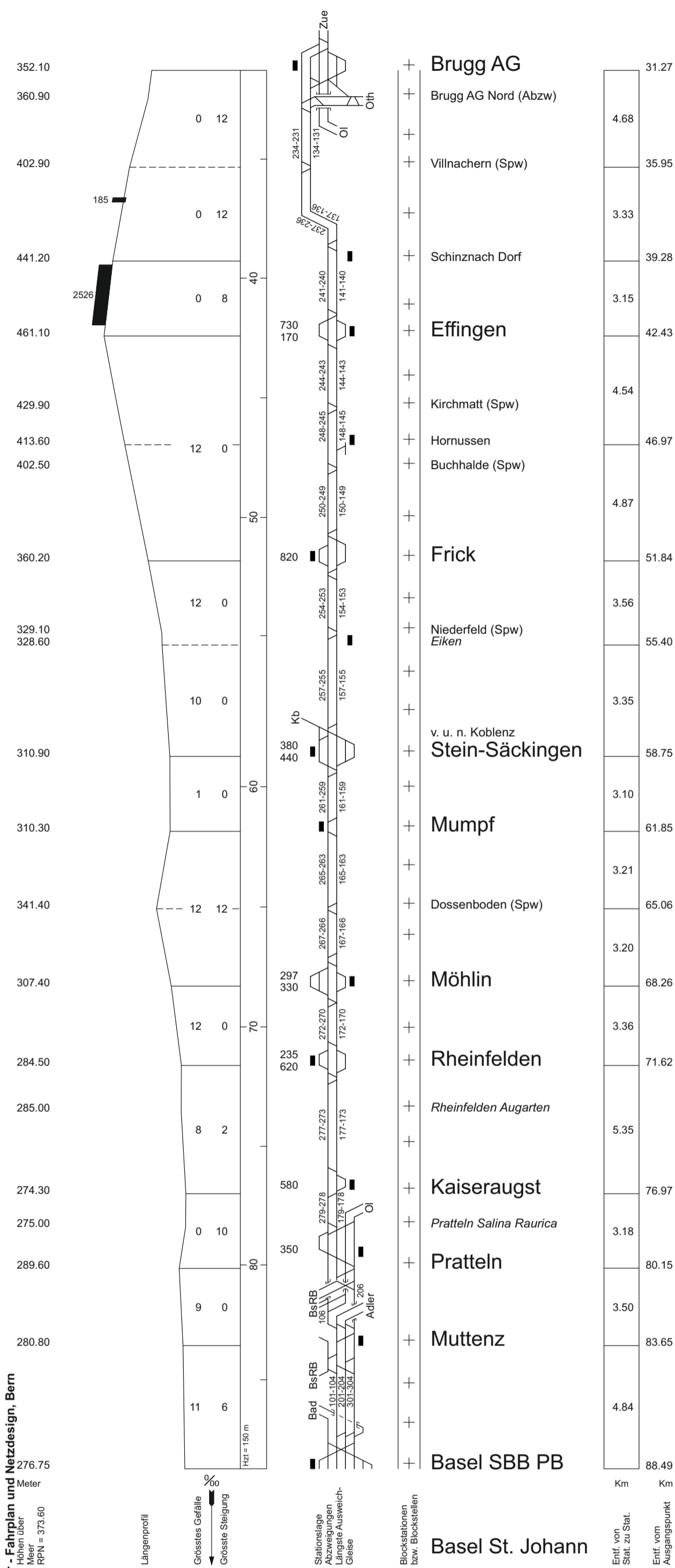

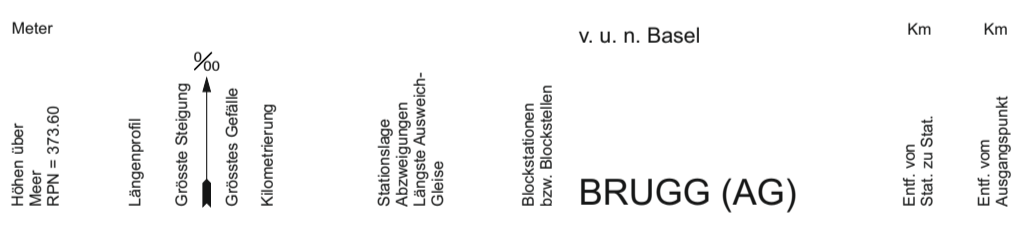
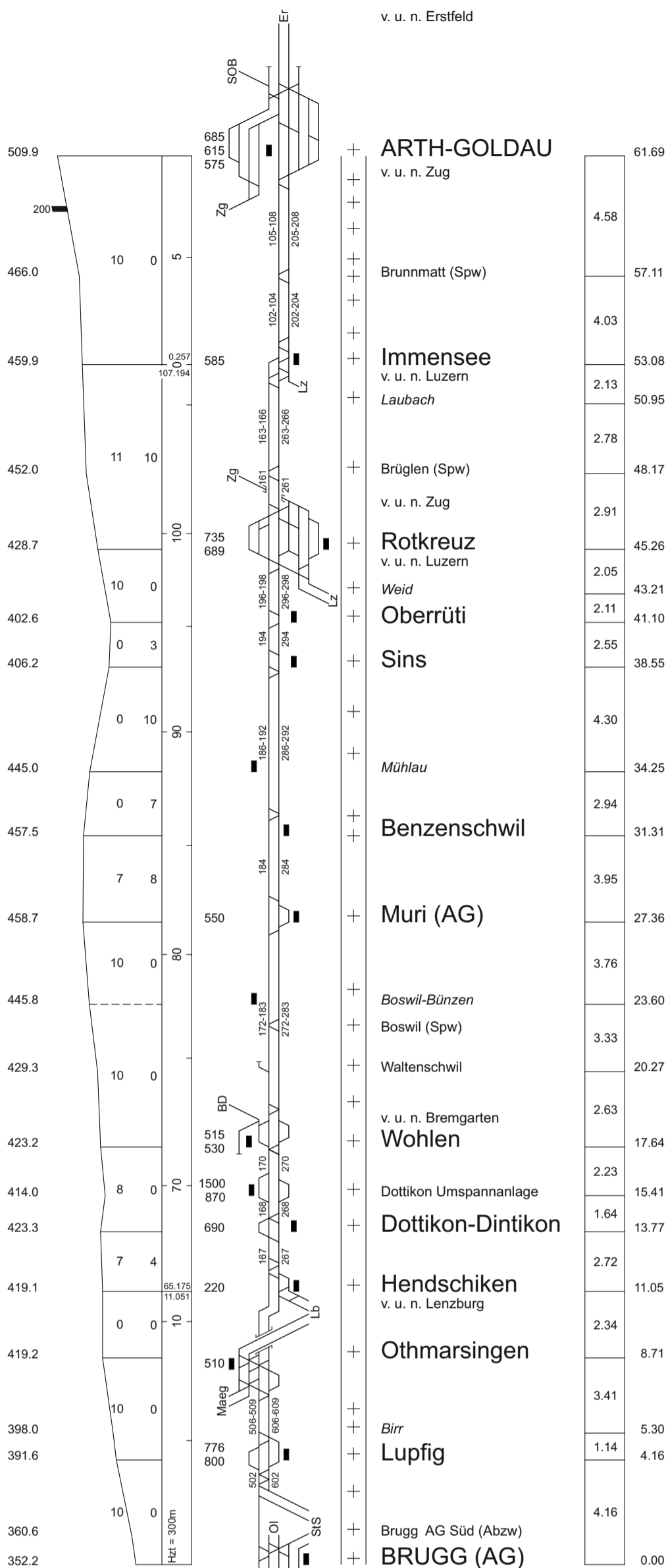

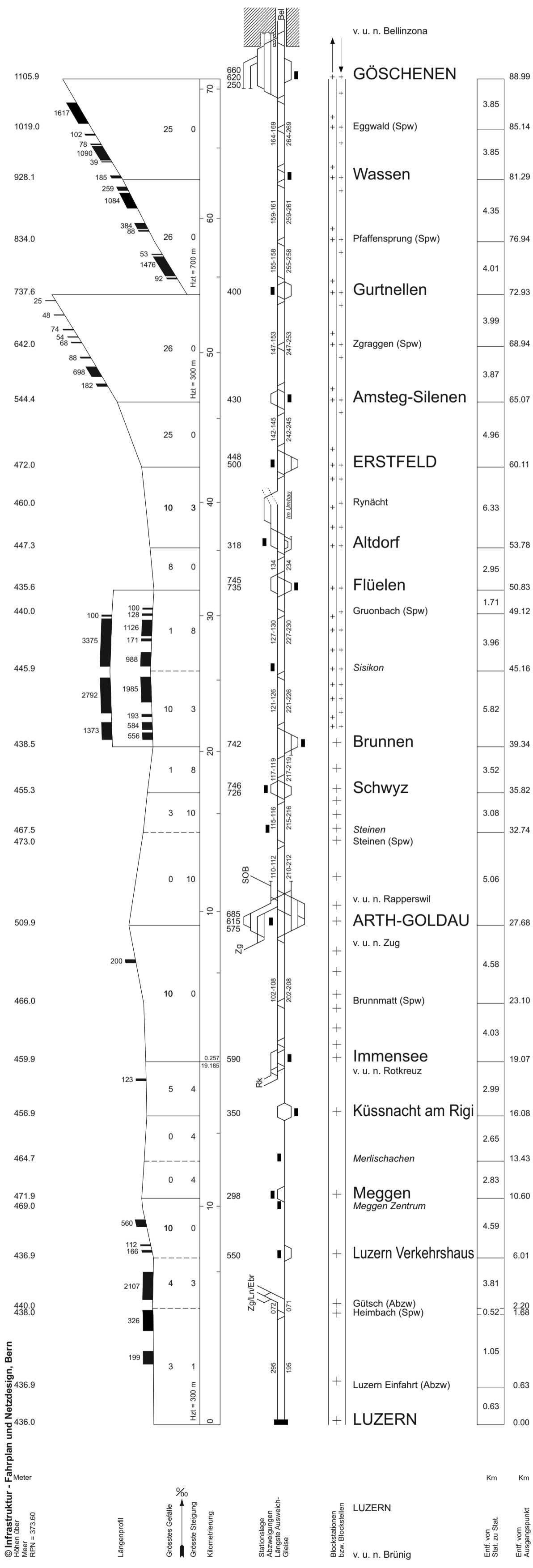

© Infrastruktur - Fahrplan und Netzdesign, Bern

Höhen über Meer RPN = 373.60

Längenprofil

Grösstes Gefälle

Grösste Steigung

Kilometrierung

Stationslage

Abzweigungen

Längste Ausweichgleise

Blockstationen bzw. Blockstellen

LUZERN v. u. n. Brünig

Entf. von Stat. zu Stat.

Entf. vom Ausgangspunkt

Km

Km

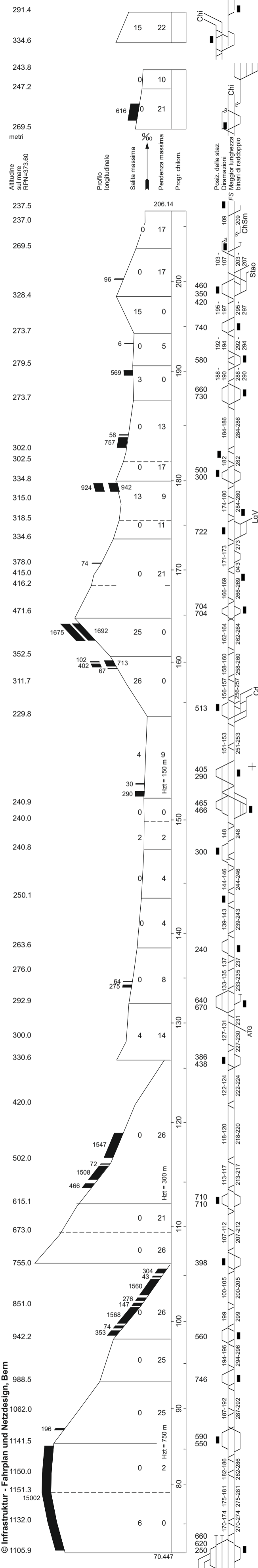

Staz. di blocco risp. posti di blocco	Dist. fra le stazioni Km	Dist. dal punto di origine Km
Chiasso		107.34
Lugano Vedeggio	3.79	103.55
Taverne-Torricella		135.61
Chiasso SM	1.05	134.56
Balerna	1.50	133.06
Chiasso		135.67
Balerna	2.61	133.06
Mendrisio	4.82	128.24
Mendrisio S. Martino	4.10	124.14
Capolago-R.S.V.	3.58	120.56
Maroggia-Melano	3.81	116.75
Melide	4.01	112.74
Lugano Paradiso (c bin) Lugano Paradiso	0.37	112.37
Lugano	2.39	109.98
Lamone (c bin)	2.58	107.40
Lamone-Cadempino da e per Lugano Vedeggio	1.77	105.63
Taverne-Torricella	2.08	103.55
Sigirino	2.70	100.85
Mezzovico (c bin) Mezzovico	1.30	99.55
	1.17	98.38
Rivera-Bironico	3.64	94.74
Al Motto (c bin)	3.82	90.92
Vigana (c bin) da e per Luino/Locarno	3.35	87.57
Giubiasco	4.00	93.57
Bellinzona Sud	3.15	80.42
Bellinzona	1.13	79.29
Bellinzona Collegamento S. Paolo	2.50	76.79
Bellinzona Nord (bif)	3.79	73.00
Castione-Arbedo	5.51	67.49
Claro	6.17	61.32
Osogna-Cresciano	6.29	55.03
Giustizia (dira)	4.37	50.66
Biasca	3.70	46.96
Pollegio Nord	4.84	42.12
Bodio	3.19	38.93
Giornico (c bin)	3.36	35.57
Pianotondo (c bin)	4.10	31.47
Lavorgo	4.10	27.37
Chiggiona (c bin)	4.79	22.58
Faido	3.37	19.21
Pardorea (c bin)	3.47	15.74
Rodi-Fiesso	4.89	10.85
Ambri-Piotta	5.95	4.90
Sordo (c bin)	4.90	0.00
Airolo		
Gottardo Sud (c bin)		
Gotthard Nord (Spw)		
Göschenen		

da e per Domodossola

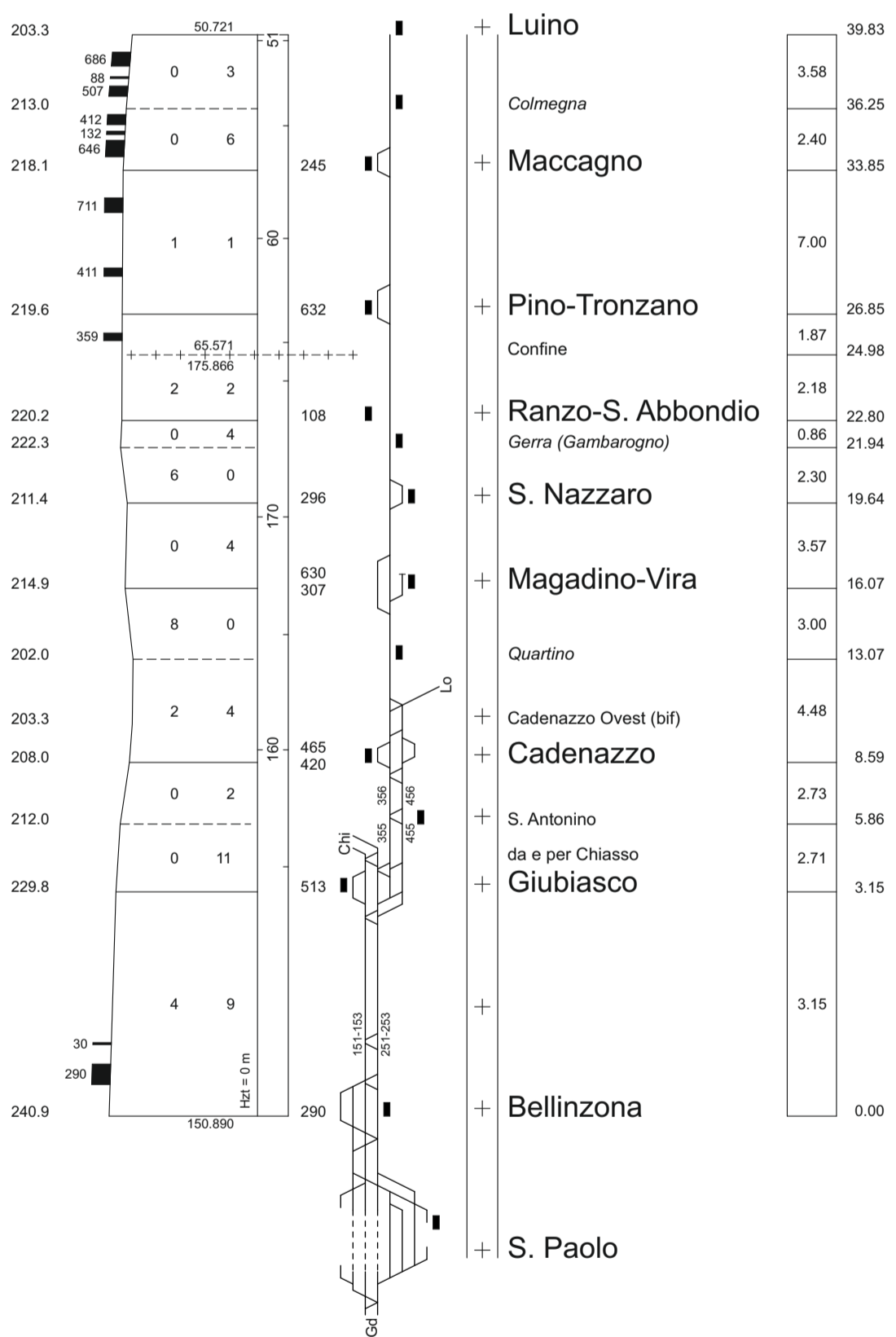

da e per Airola

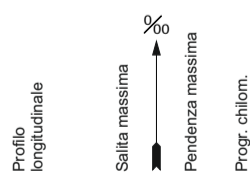

Posiz. delle staz.
 Diramazioni
 Maggior lunghezza
 binari di raddoppio

Staz. di blocco
 risp. posti di blocco

Dist. fra le stazioni
 Km
 Dist. dal punto di origine
 Km



SBB 16 A

I-FN-FPA-ROT

Ausgabe von 14.12.2014

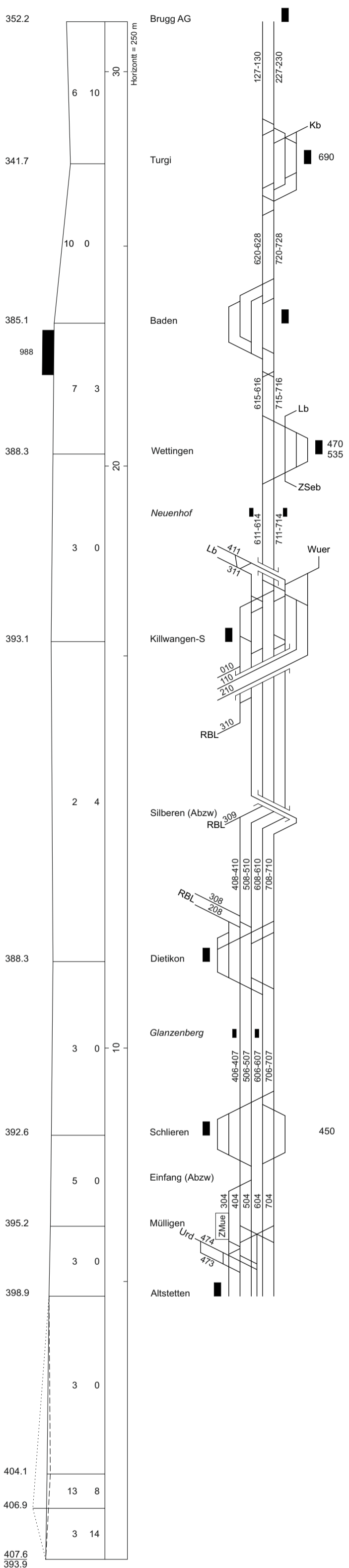

Höhe über Meer RPN = 373.60
 Längenprofil
 Grösstes Gefälle
 Grösste Steigung
 Kilometrierung

+	Killwangen-S	16.11
+		4.99
+	Dietikon	11.12
+	Glanzenberg	1.62
+	Schlieren	2.00
+		3.34
+	Z Altstetten	4.16
+	Z Hardbrücke West (Spw)	2.24
+	Z Hardbrücke 5+6	1.92
+	Z Langstrasse	1.92
+	Zürich PB A3-18	0.00

+	Brugg Nord v/n Basel	
+	Brugg AG	31.27
+	v/n Koblenz	3.84
+	Turgi	27.43
+		4.90
+	Baden	22.53
+		2.27
+	Wettingen	20.26
+	v/n Z Seebach	1.50
+	Neuenhof	18.76
+		2.65
+	Killwangen-S	16.11
+	Silbernen (Abzw)	2.80
+	Dietikon	2.19
+	Glanzenberg	1.62
+		2.00
+	Schlieren	7.50
+	Einfang (Abzw)	1.19
+		2.15
+	Z Altstetten	4.16
+	Z Hardbrücke 1+4	2.24
+	Z Langstrasse	1.92
+	Zürich PB S21-24	0.00

+	Einfang (Abzw)	0.65
+	Z Mülligen	0.94
+	Z Altstetten	2.08
+	Gl. 242/142	2.08
+	Zürich VB	2.08
+	Zürich VB Nord	2.08
+	Gl. M 1-3	2.08
+	Zürich PB A3-18	1.37
+	Z Altstetten	0.71
+	Gl. 215	1.37
+	Zürich VB West (Feld Z)	0.71
+	Zürich VB	2.08
+	Z Altstetten	2.08
+	Gl. 694	2.08
+	Zürich VB	2.08
+	Zürich VB Ost Gl. 691/791	2.08
+	Zürich PB A3-18	2.08
+	Q51-54	

+	Urdorf	4.41
+	v/n Zug	2.35
+	Z Altstetten	3.08
+	Hard Käferberg (Abzw)	
+		
+	Z Oerlikon	



I-FN-FPA-ROT

Ausgabe von 14.12.2014

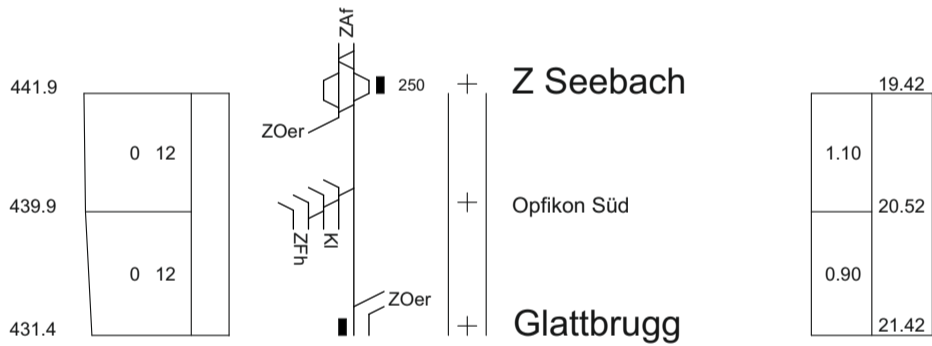
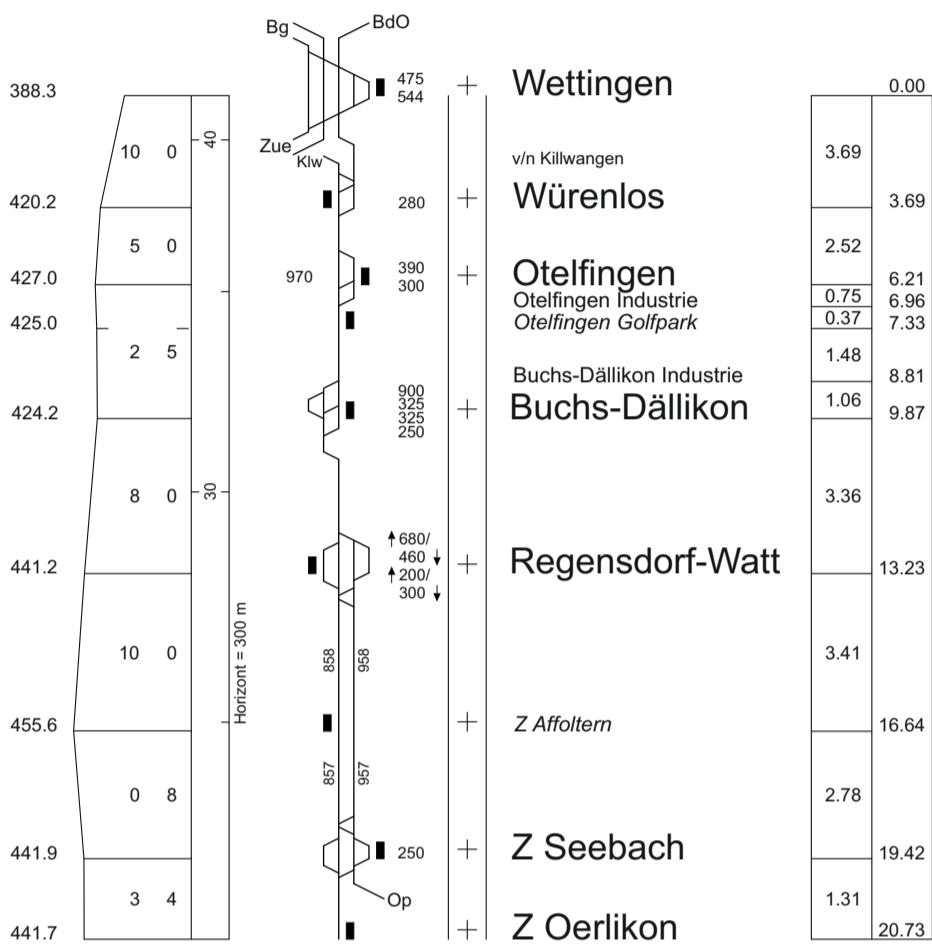
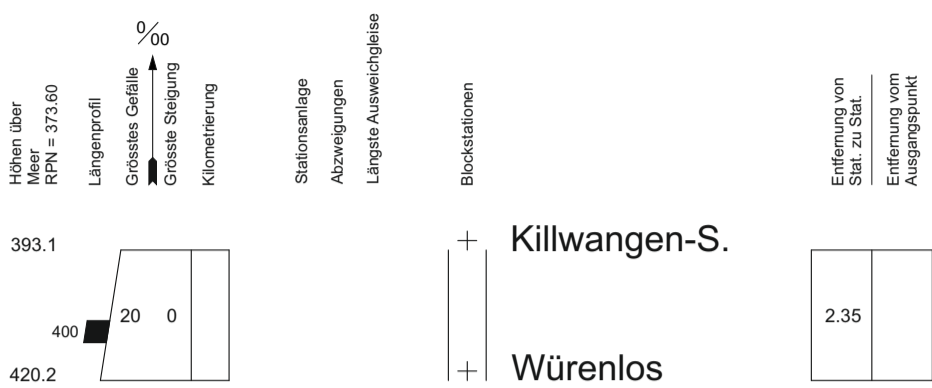





SBB 60

I-FN-FPA-ROT

Ausgabe von 14.12.2014

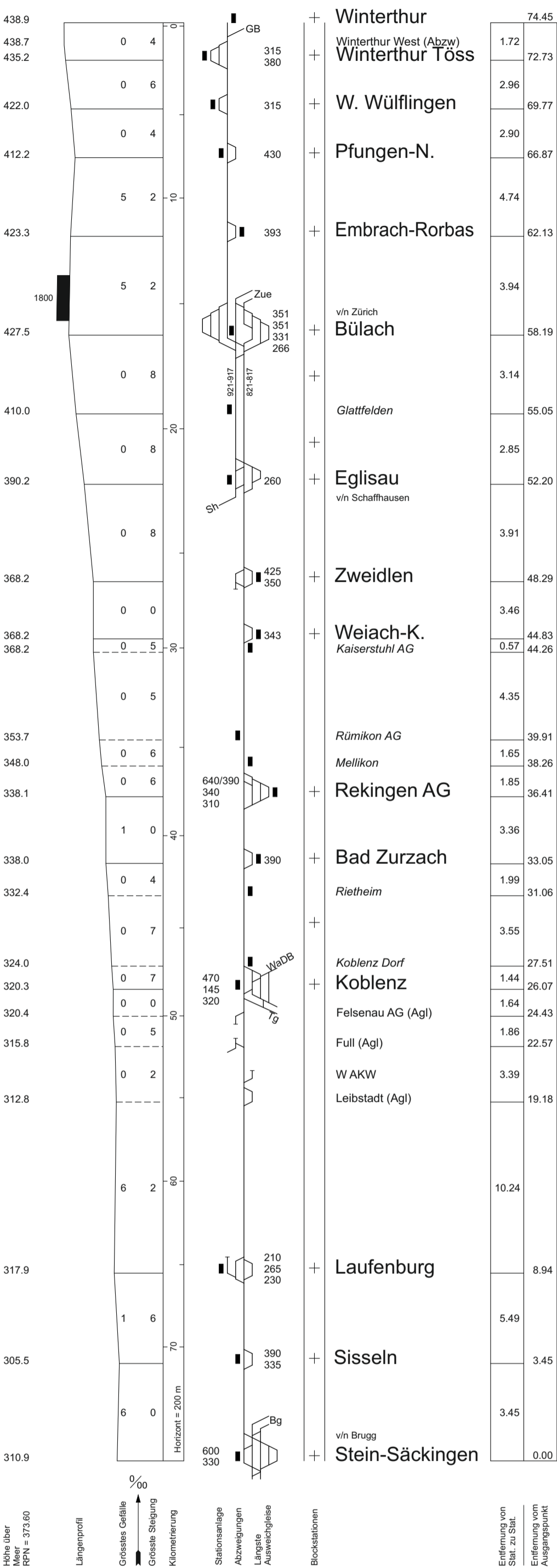

© Infrastruktur - Fahrplan und Netzdesign, Bern

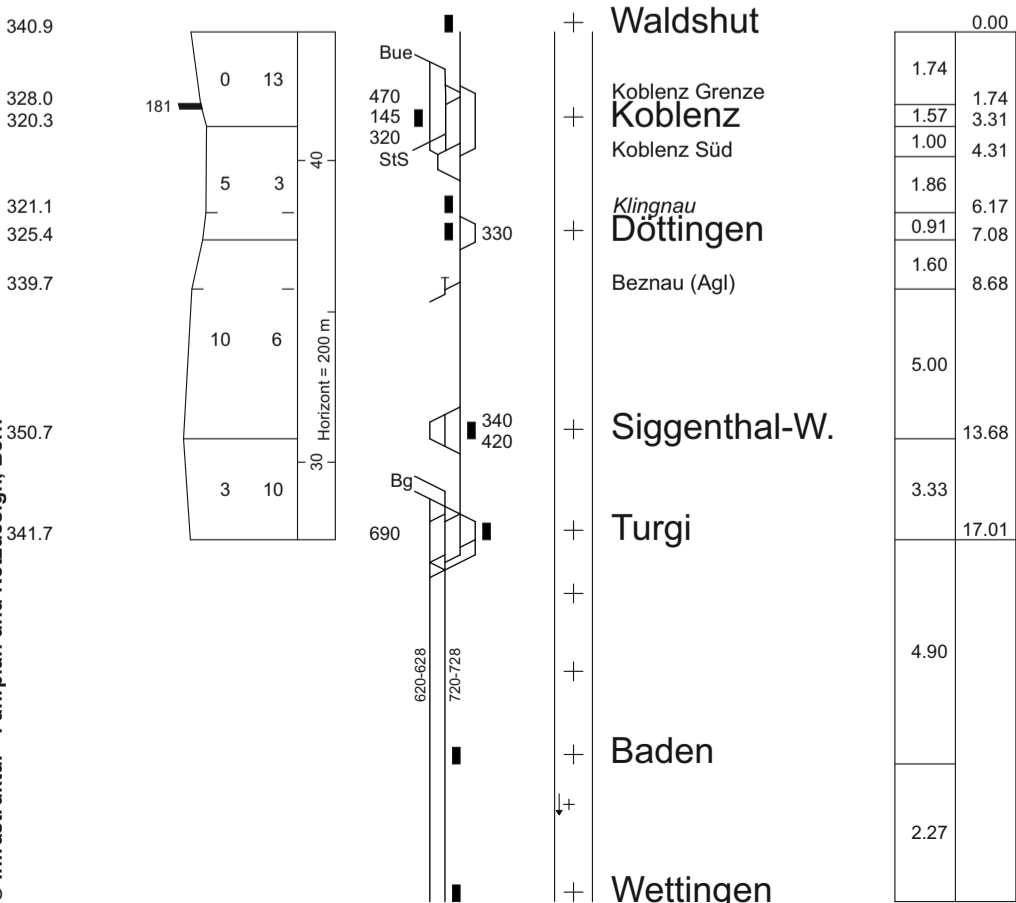



SBB 61

I-FN-FPA-ROT

Ausgabe von 14.12.2014

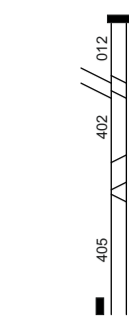
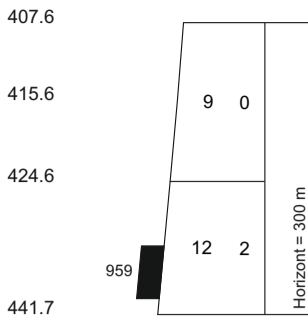

+	Zürich PB A 3-18	0.00
+	Z Viadukt (Abzw)	1.40
+	Z Wipkingen	1.49
+	Z Birchsteg (Abzw)	1.80
+	Z Oerlikon	0.62
		4.69
		5.31

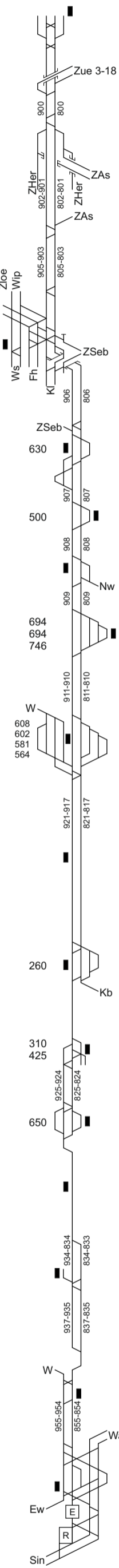
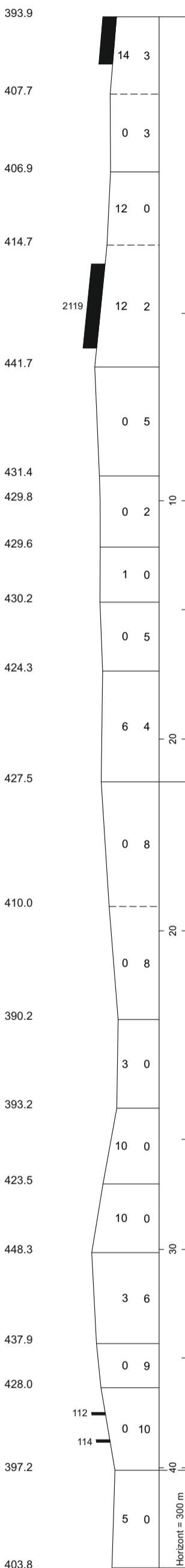

+	Zürich PB S21-24	0.00
+	Z Langstrasse	1.92
+	Z Hardbrücke	1.92
+	v/n Altstetten	1.35
+	Hard Käferberg (Abzw)	3.27
+		3.08
+	Z Birchsteg (Abzw)	
+	Z Oerlikon	6.35
+	v/n Seebach	2.49
+	Glattbrugg	8.84
+	Tankanlage Rümlang	3.34
+	Rümlang	12.18
+	Oberglatt	2.59
+	v/n Niederweningen	2.12
+	Niederglatt	16.89
+		5.06
+	v/n Winterthur	
+	Bülach	21.95
+		3.14
+	Glattfelden	25.09
+		2.85
+	Eglisau	27.94
+	v/n Koblenz	1.35
+	Hüntwangen-Wil	29.29
+		3.44
+	Rafz	32.73
+		3.12
+	Lottstetten	35.85
+		2.34
+	Jestetten Süd (Verzw)	38.19
+	Jestetten	40.02
+		1.83
+	Fischerhölzli (Verzw)	43.59
+	v/n Winterthur	2.22
+	Neuhausen	45.81
+		2.23
+	Schaffhausen	48.04
+	Schaffhausen GB	

Höhe über Meer RPN=373.60
 Längenprofil
 Grösstes Gefälle
 Grösste Steigung
 Kilometrierung

Stationsanlage
 Abzweigungen
 Längste Ausweichgleise

Blockstationen
 Entfernung von Stat. zu Stat.
 Entfernung vom Ausgangspunkt

© Infrastruktur - Fahrplan und Netzdesign, Bern

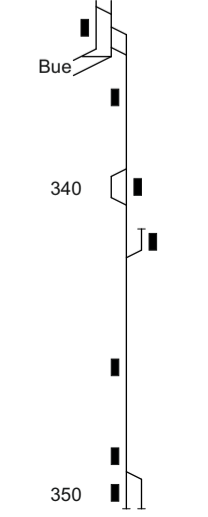
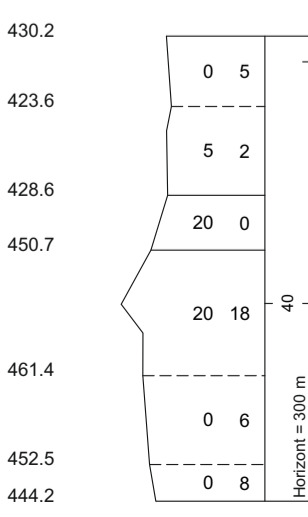

+	Oberglatt	0.00
+	Niederhasli	1.92
+		2.40
+	Dielsdorf	4.32
+	Steinmaur	1.33
+		5.65
+	Schöffliisdorf-Oberweningen	2.86
+		8.51
+	Niederweningen Dorf	2.47
+		10.98
+	Niederweningen	1.06
		12.04



I-FN-FPA-ROT

Ausgabe von 14.12.2014

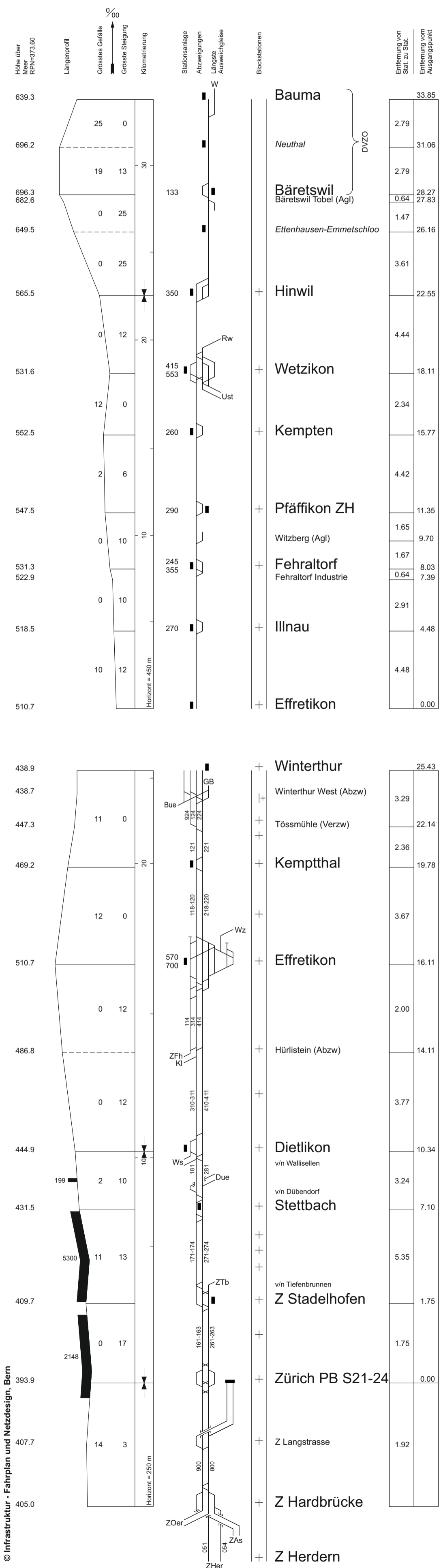



SBB 70 A

I-FN-FPA-ROT

Ausgabe von 14.12.2014

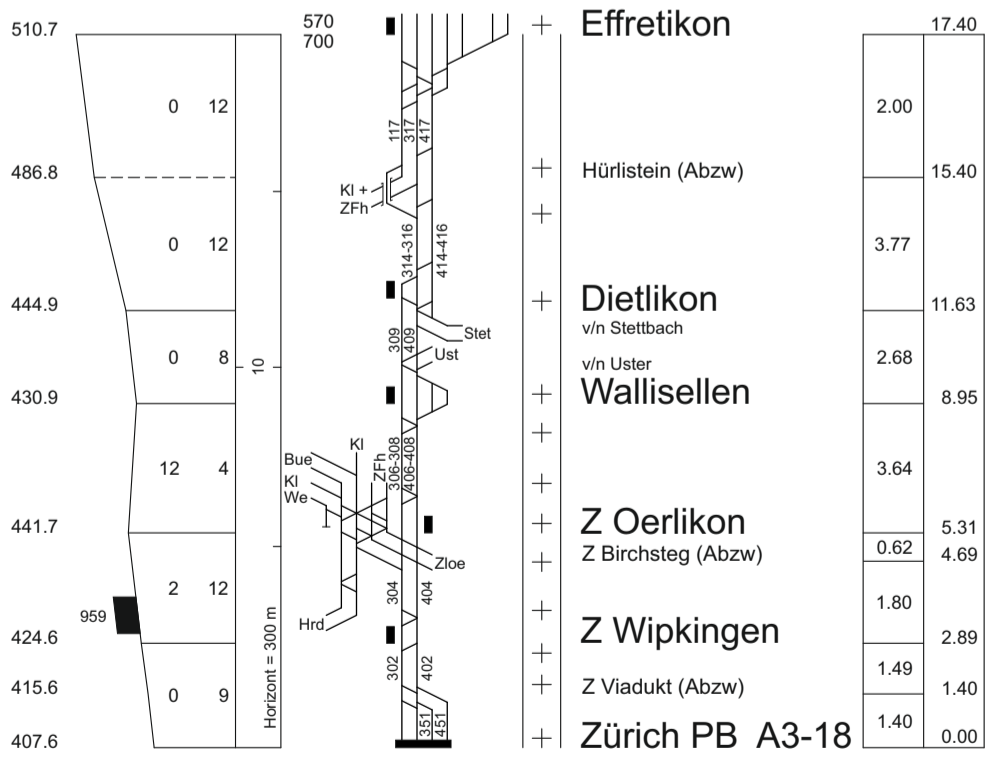
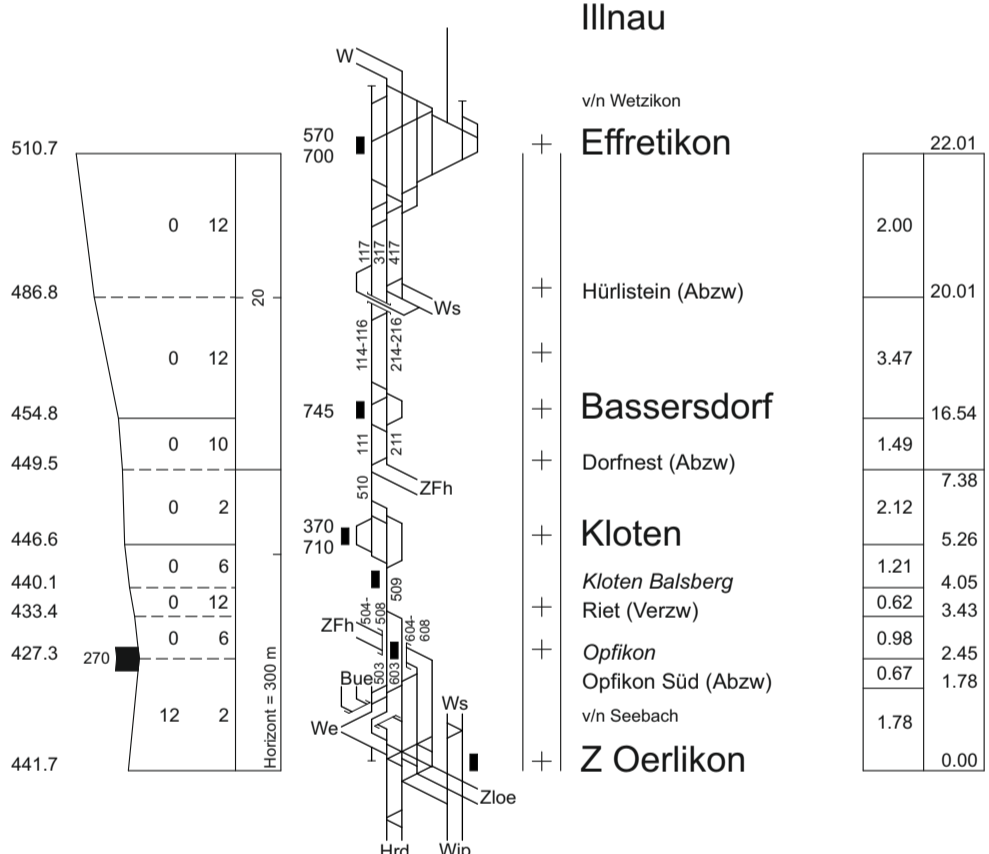
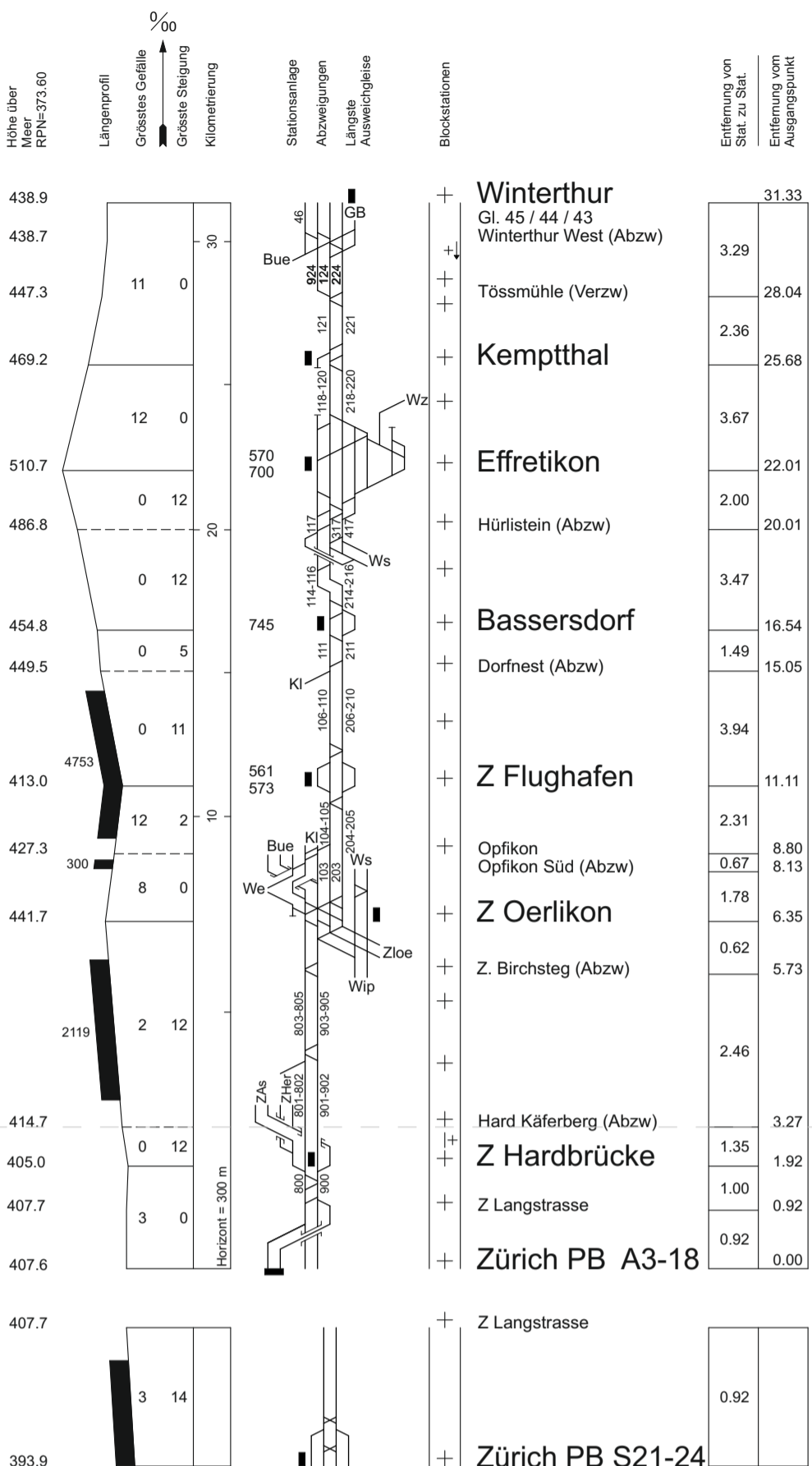

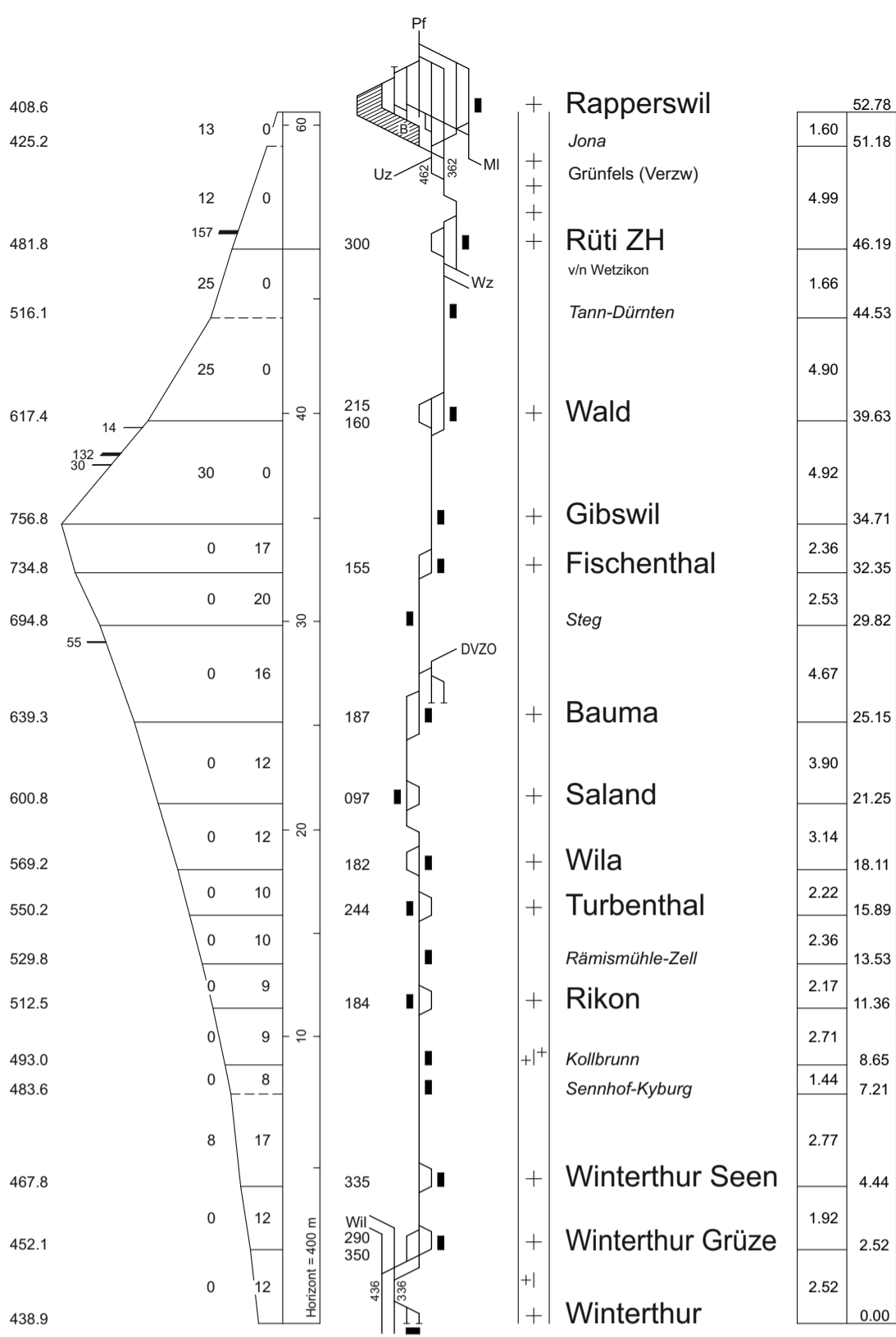

SBB 71

I-FN-FPA-ROT

Ausgabe von 14.12.2014

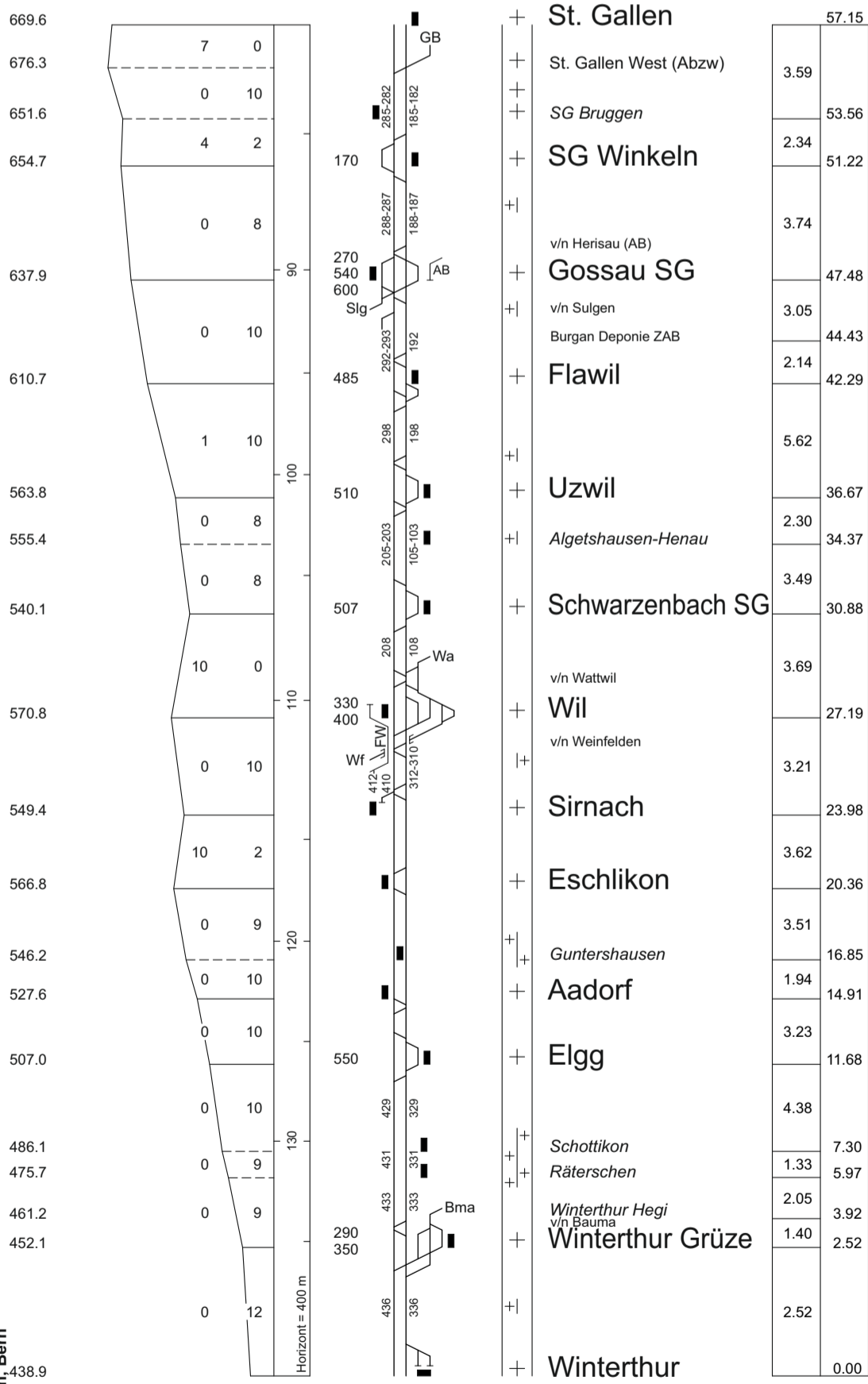



I-FN-FPA-ROT

Ausgabe von 14.12.2014

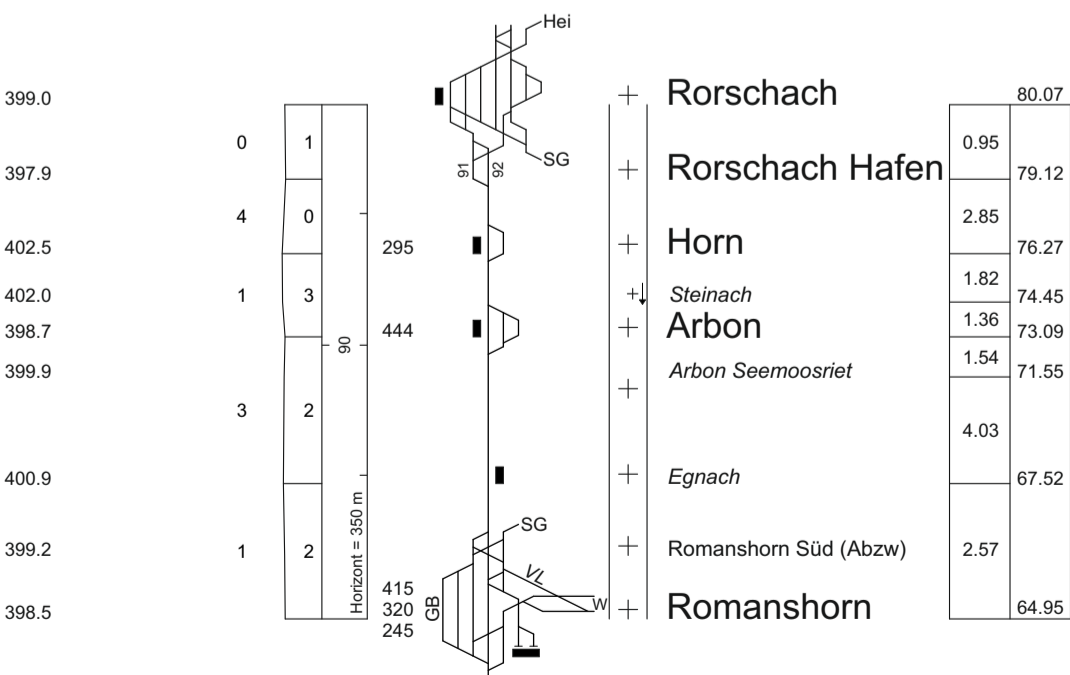
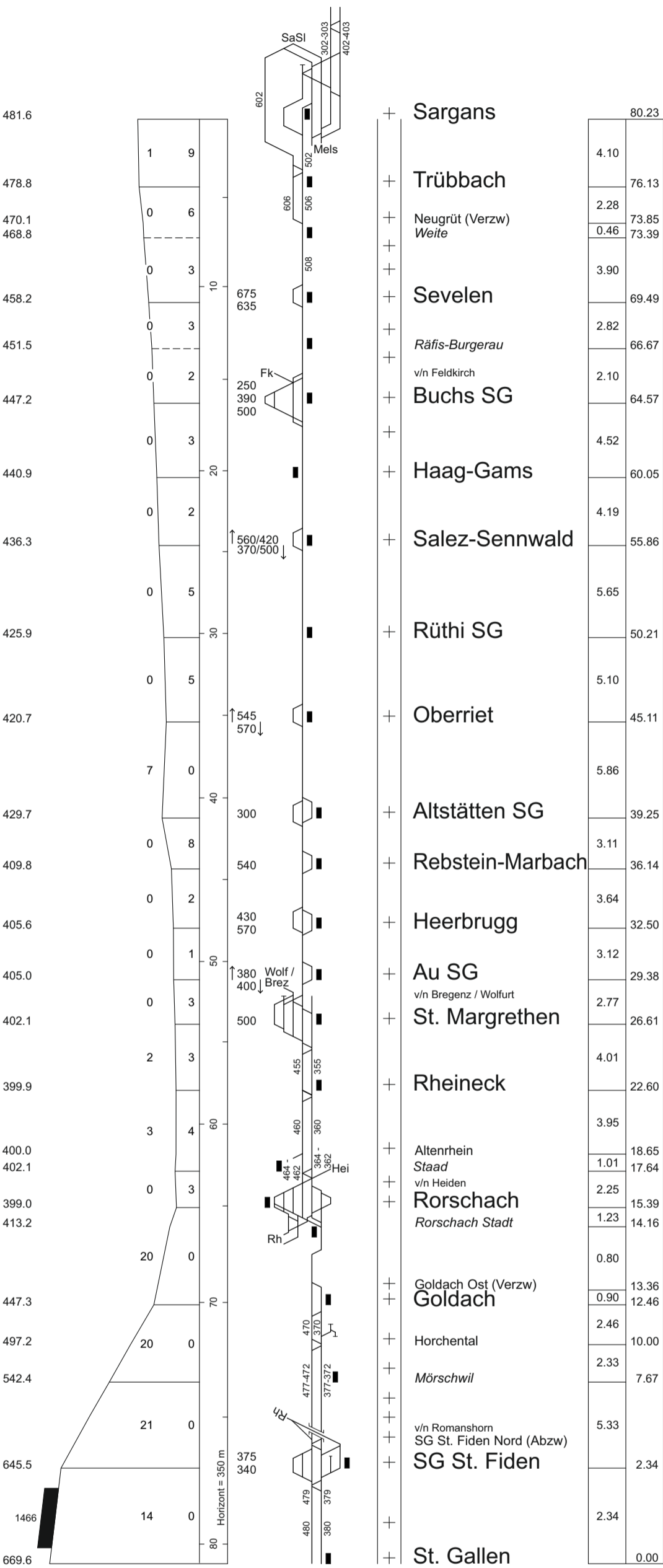
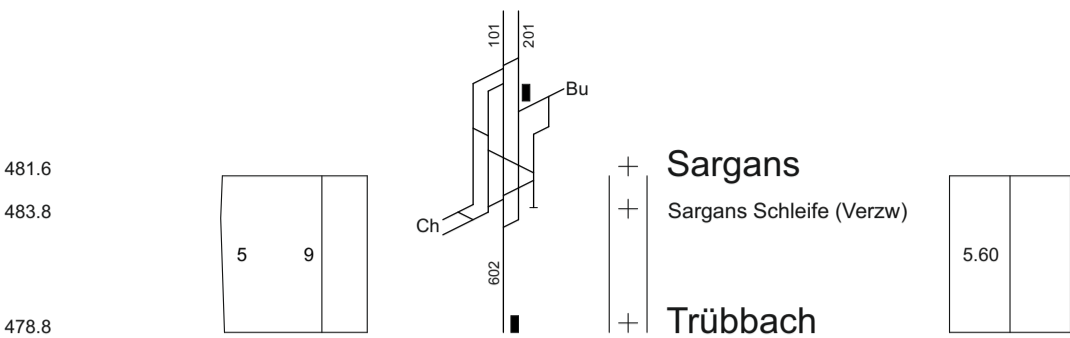

Höhe über Meer RPN=373.60

Längenprofil

Grösstes Gefälle
Grösste Steigung
Kilometrierung

Stationsanlage
Abzweigungen
Längste Auswechseleise

Blockstationen

Entfernung von Stat. zu Stat.
Entfernung vom Ausgangspunkt



SBB 73

I-FN-FPA-ROT

Ausgabe von 14.12.2014

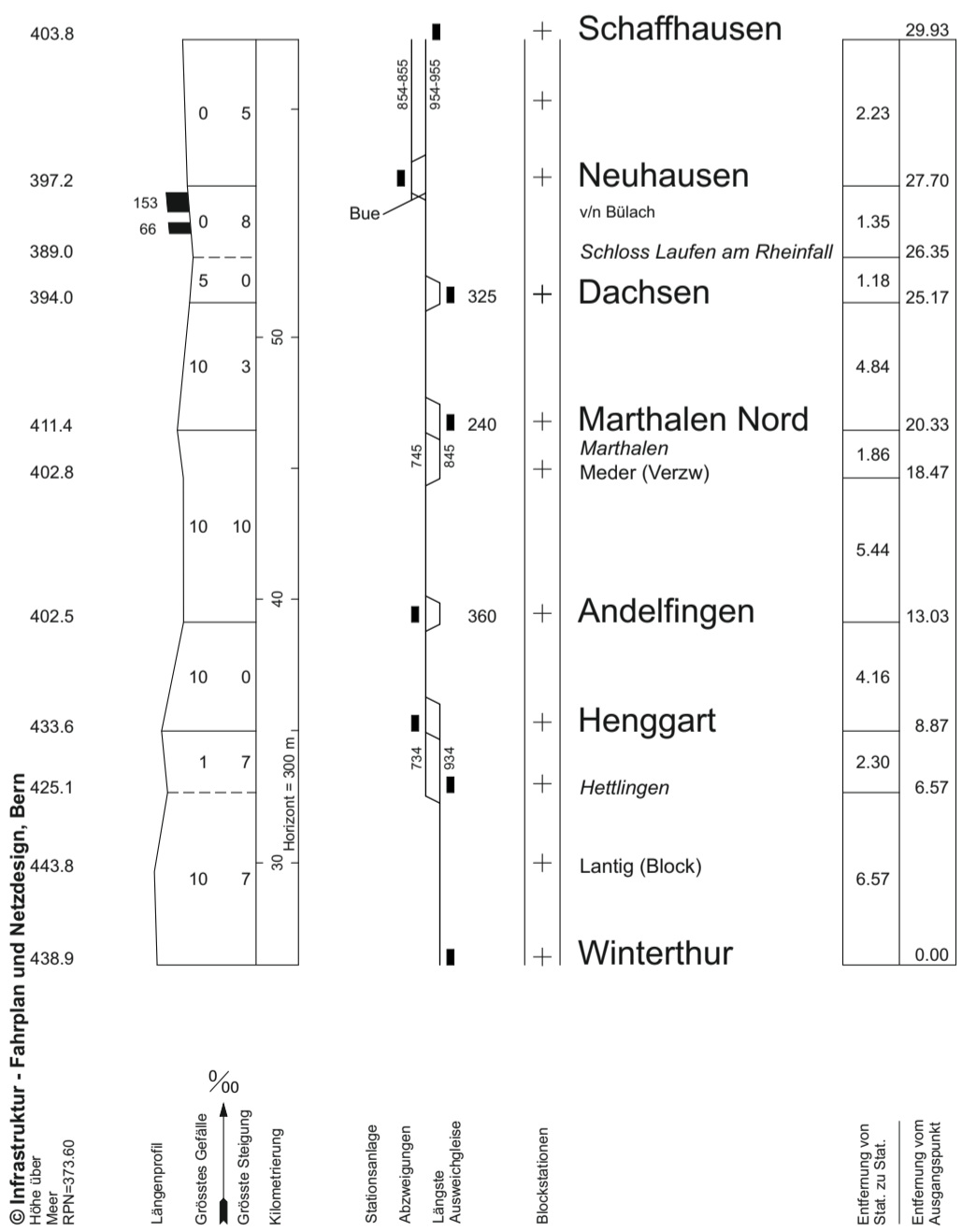
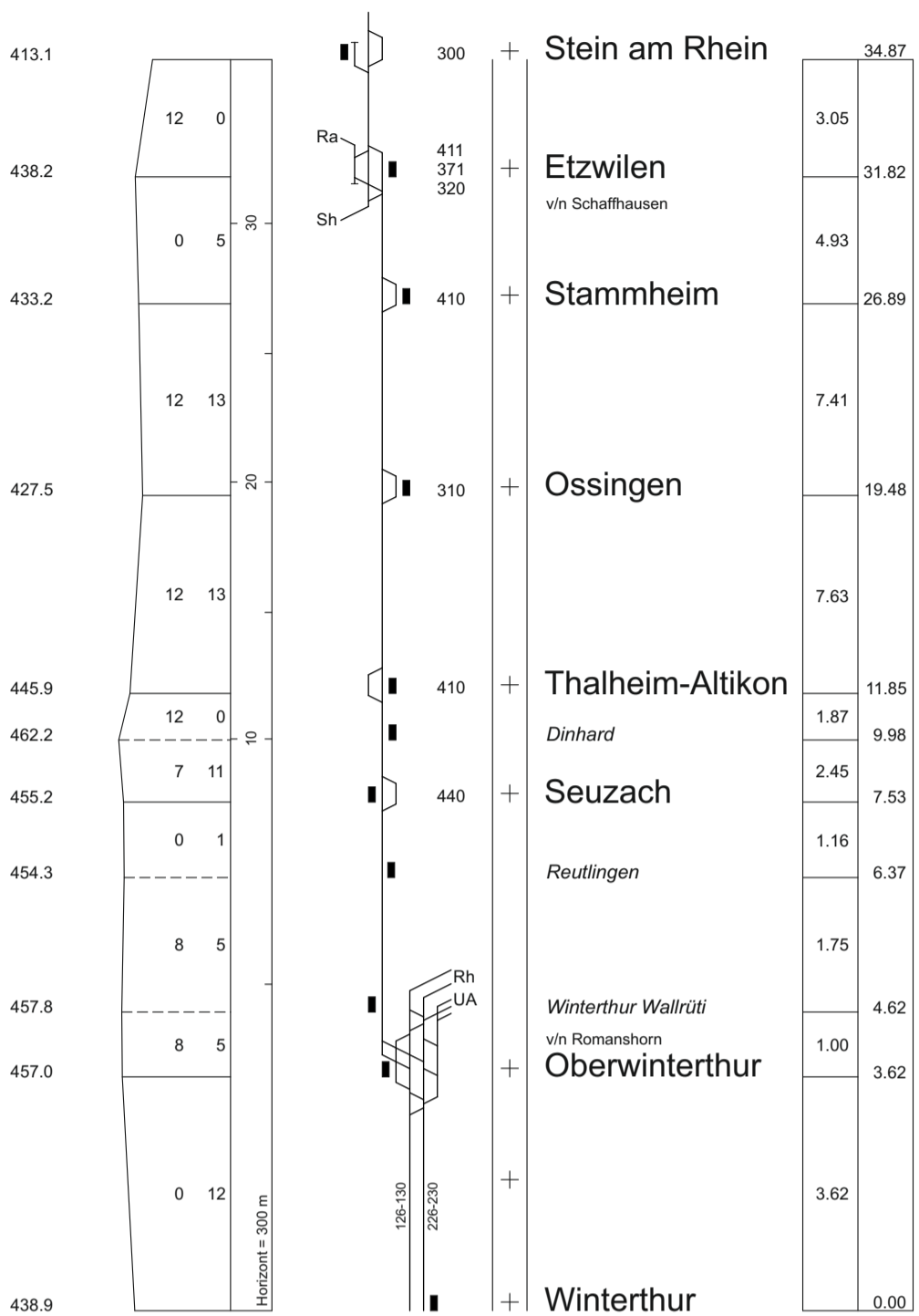

© Infrastruktur - Fahrplan und Netzdesign, Bern
Höhe über Meer
RPN=373.60

Längenprofil
Grösstes Gefälle
Grösste Steigung
Kilometrierung

Stationsanlage
Abzweigungen
Längste Ausweichleise

Blockstationen

Entfernung von Stat. zu Stat.
Entfernung vom Ausgangspunkt



SBB 74

I-FN-FPA-ROT

Ausgabe von 14.12.2014

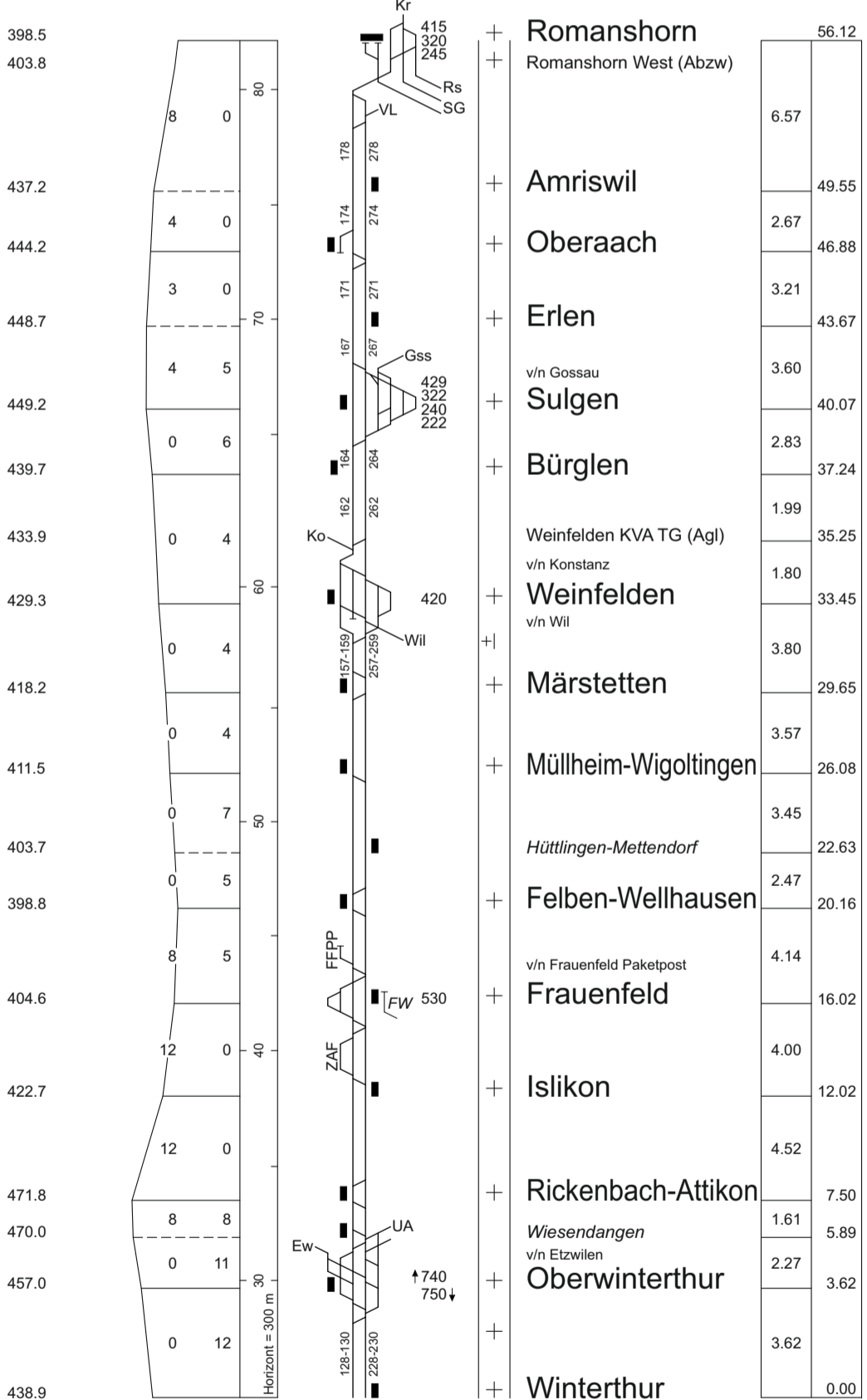
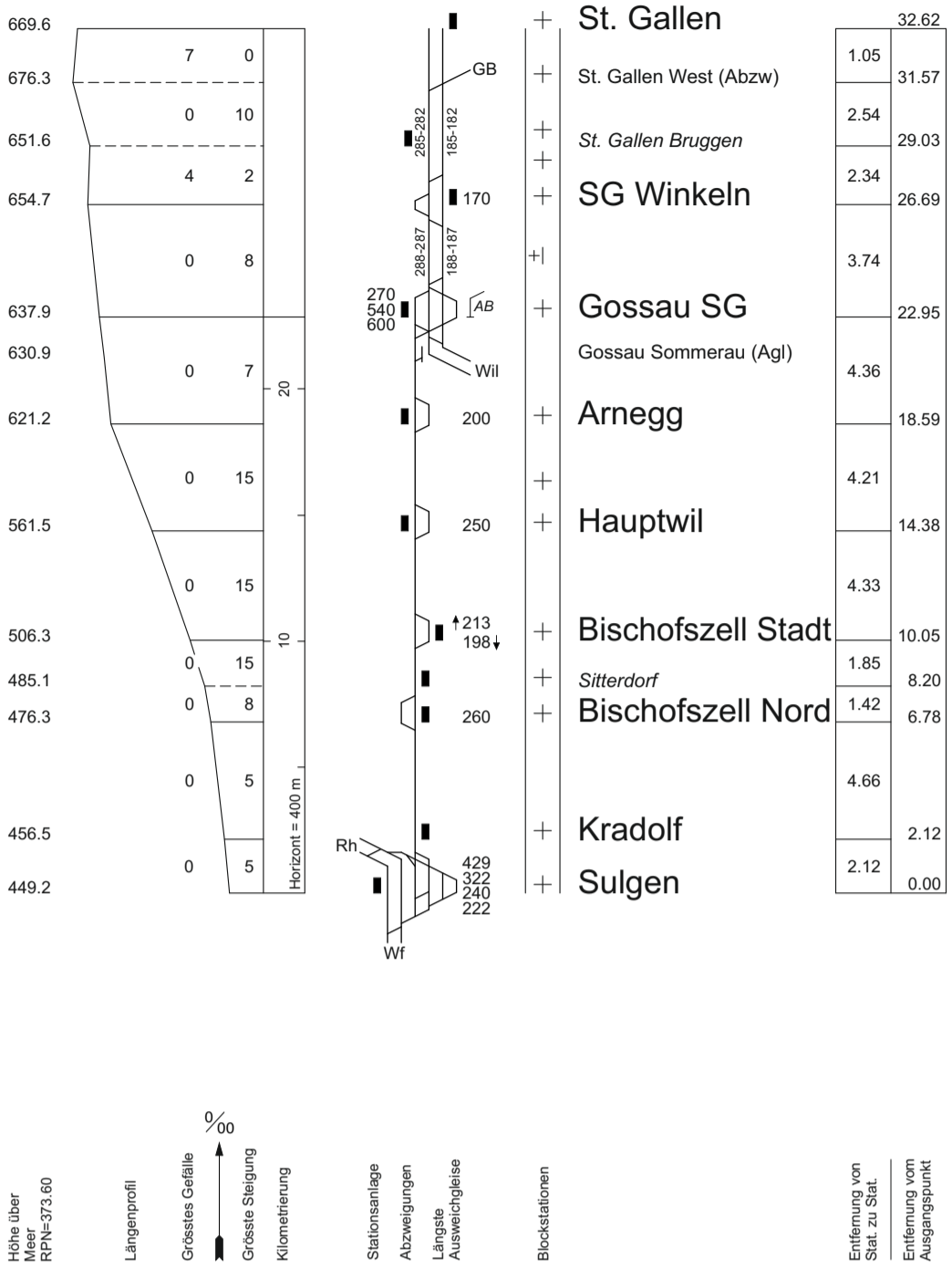



SBB 75

I-FN-FPA-ROT

Ausgabe von 14.12.2014

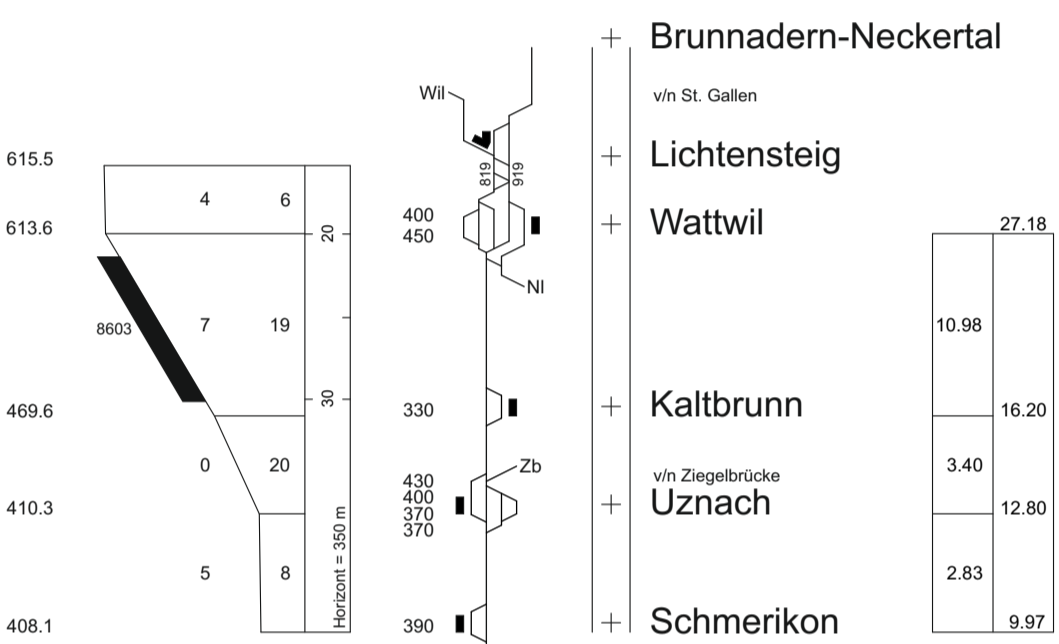
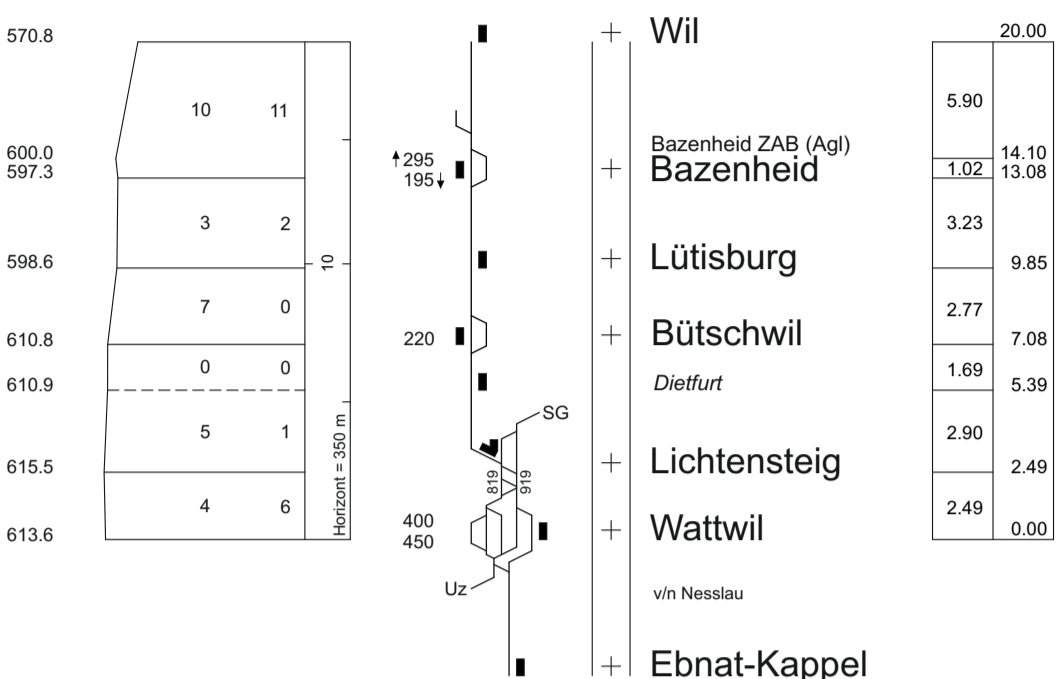

Höhe über Meer RPN=373.60

Längenprofil

Grösstes Gefälle

Grösste Steigung

Kilometrierung

Stationsanlage

Abzweigungen

Längste Auswechseleise

Blockstationen

Entfernung von Stat. zu Stat.

Entfernung vom Ausgangspunkt

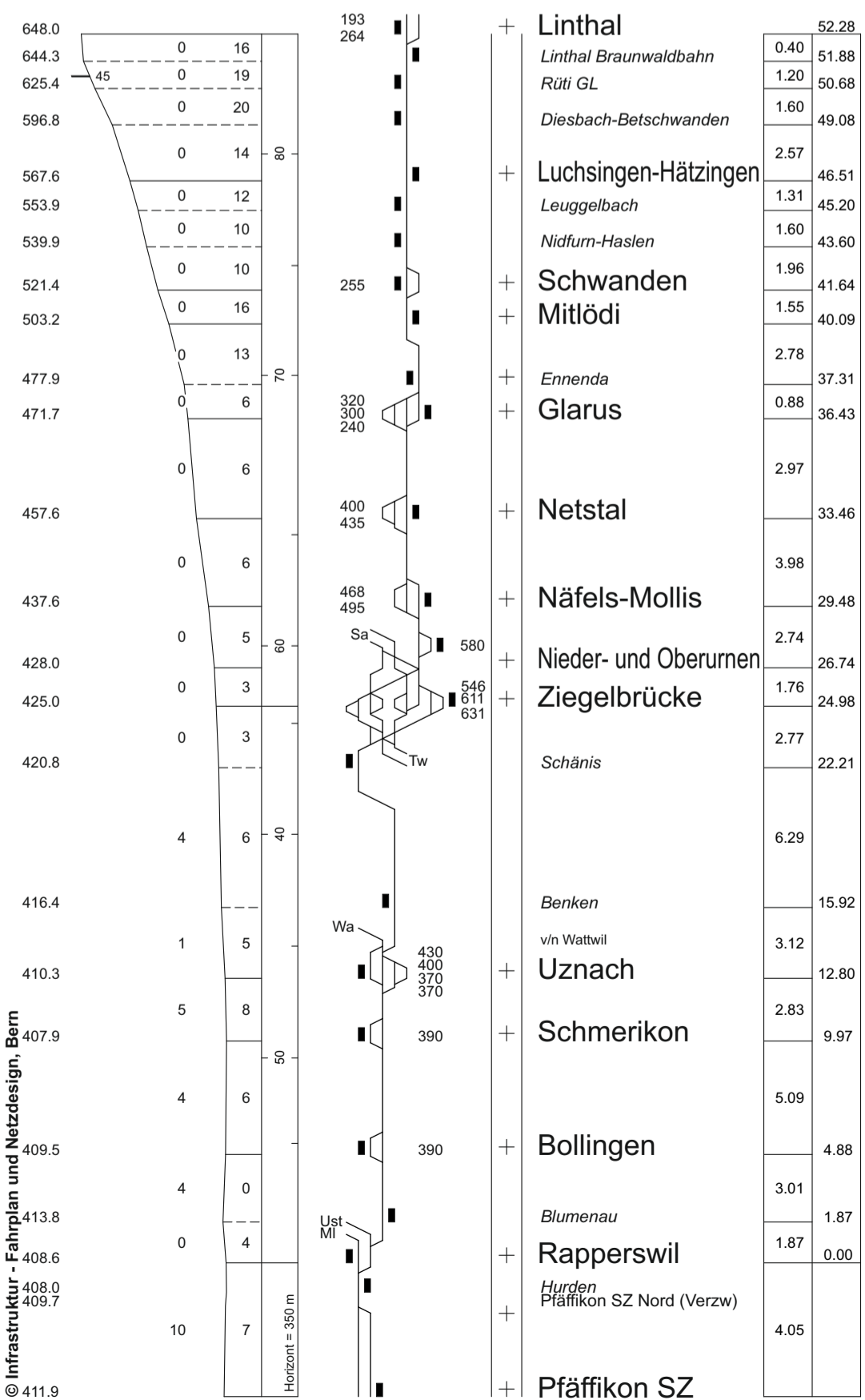

© Infrastruktur - Fahrplan und Netzdesign, Bern



I-FN-FPA-ROT

Ausgabe von 14.12.2014

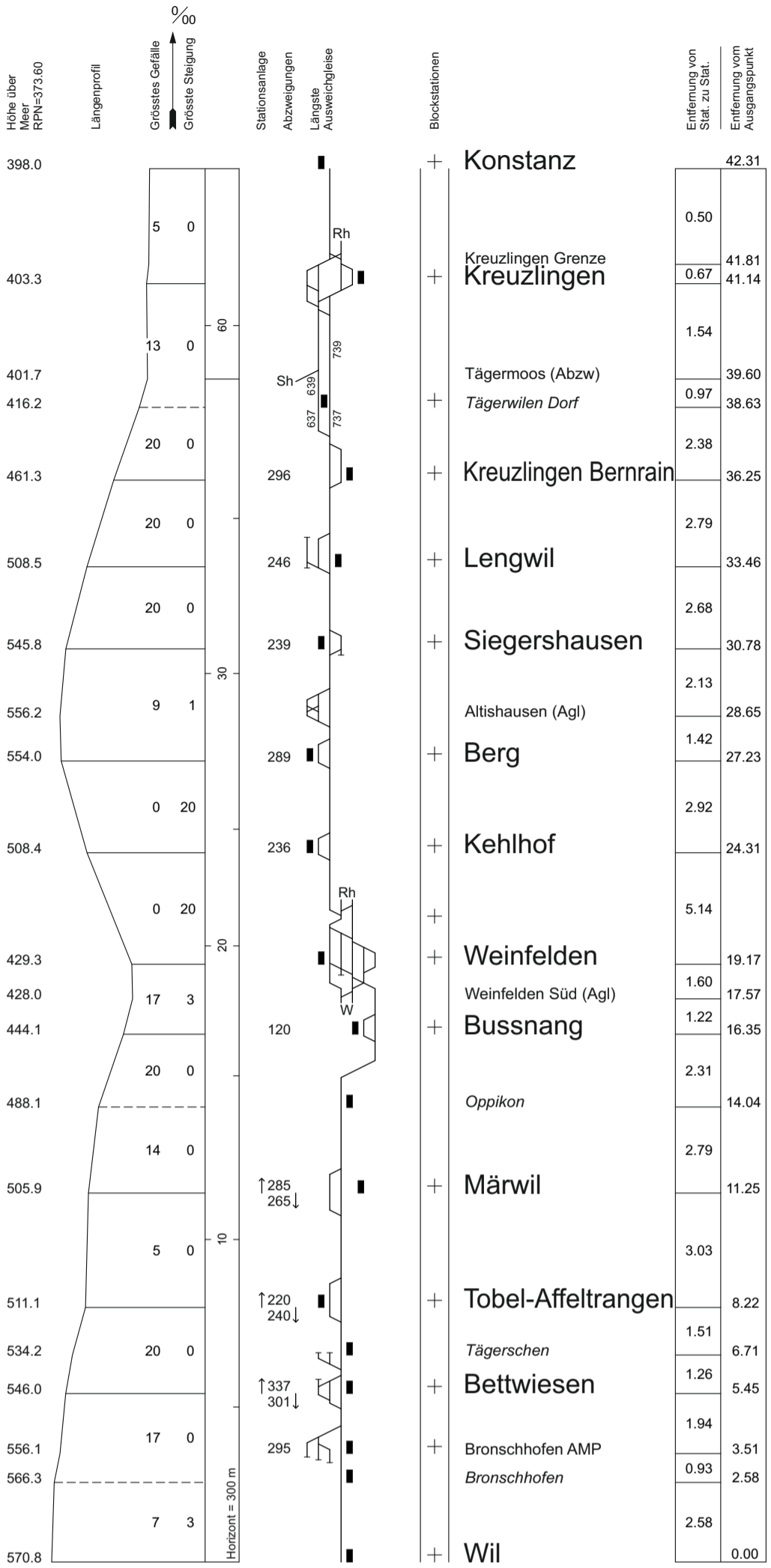



SBB 77

I-FN-FPA-ROT

Ausgabe von 14.12.2014

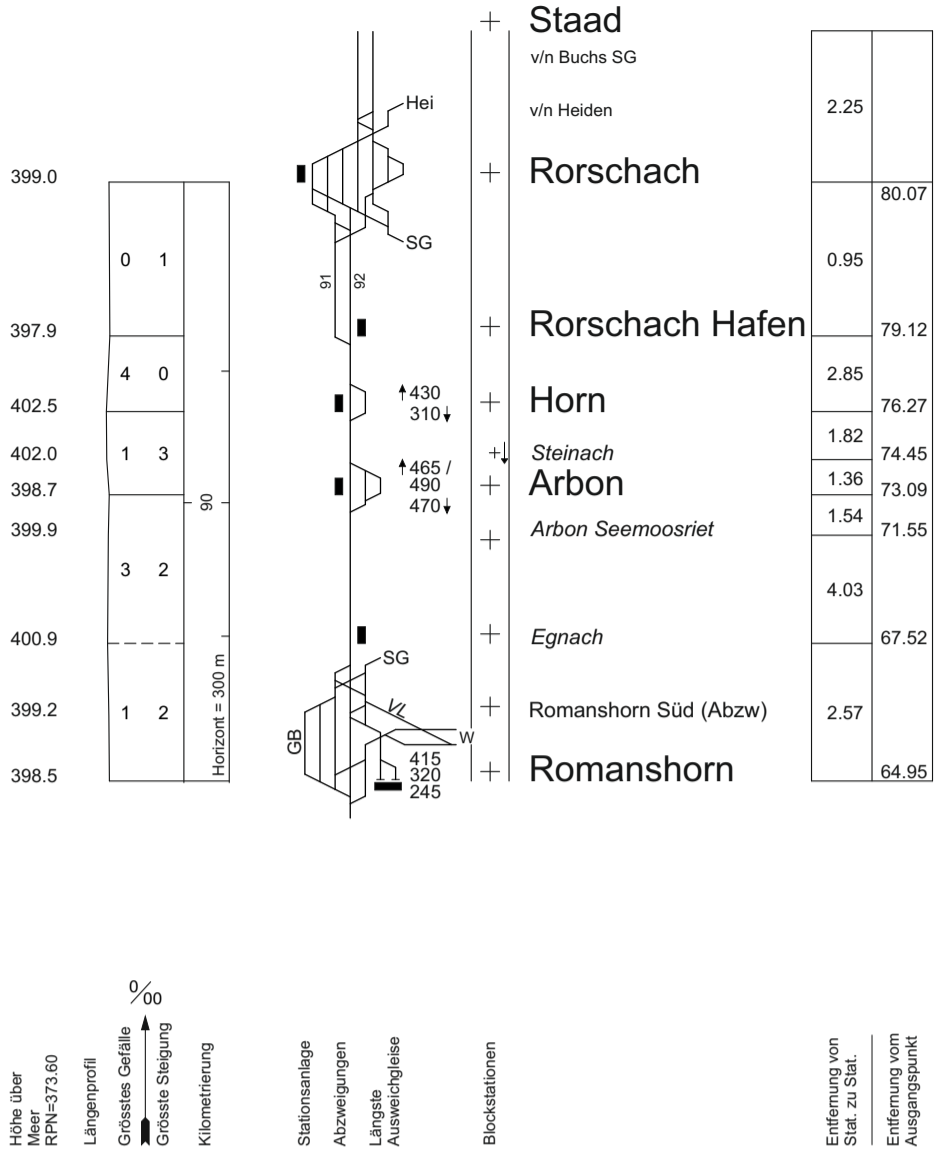

Höhe über Meer
RPN=373.60

Längenprofil
Grösstes Gefälle
Grösste Steigung
Kilometrierung

Stationsanlage
Abzweigungen
Längste Ausweicheise

Blockstationen

Entfernung von Stat. zu Stat.
Entfernung vom Ausgangspunkt

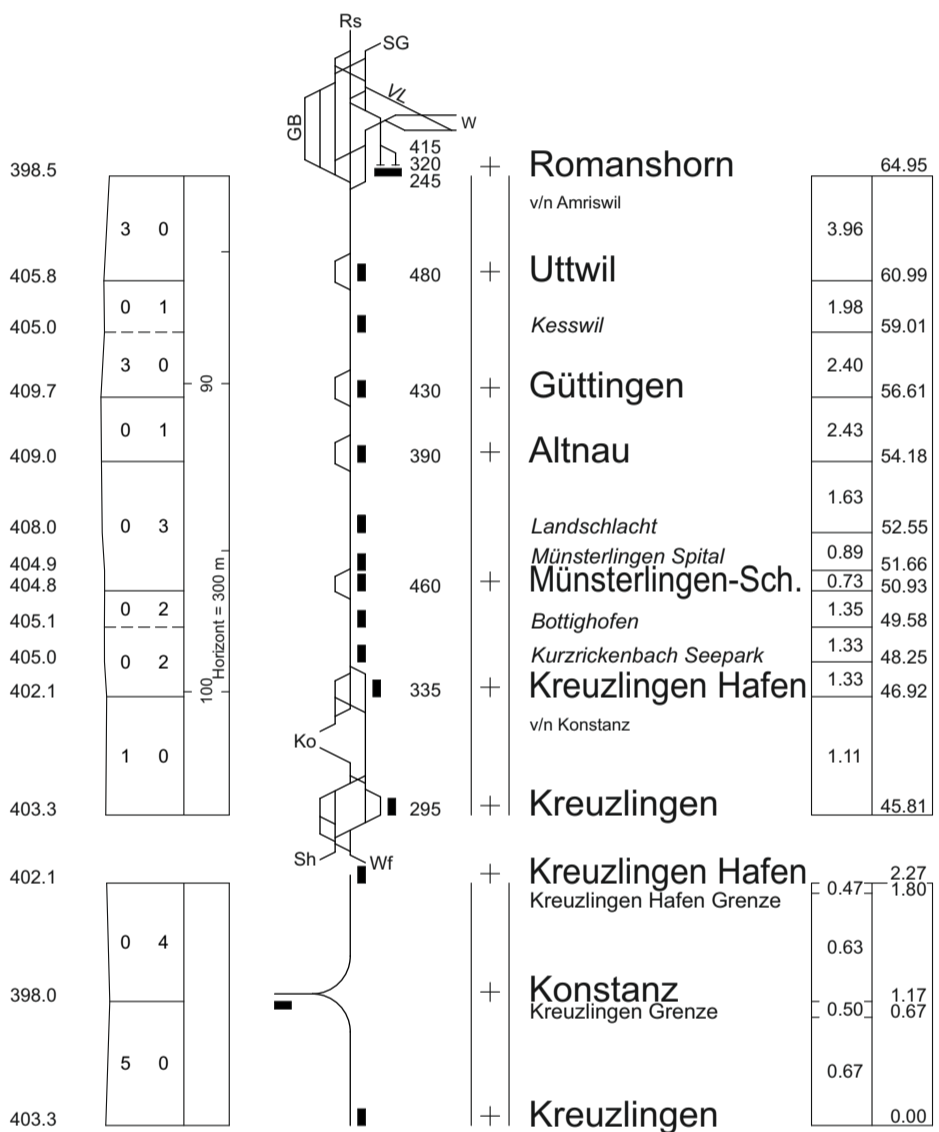

© Infrastruktur - Fahrplan und Netzdesign, Bern

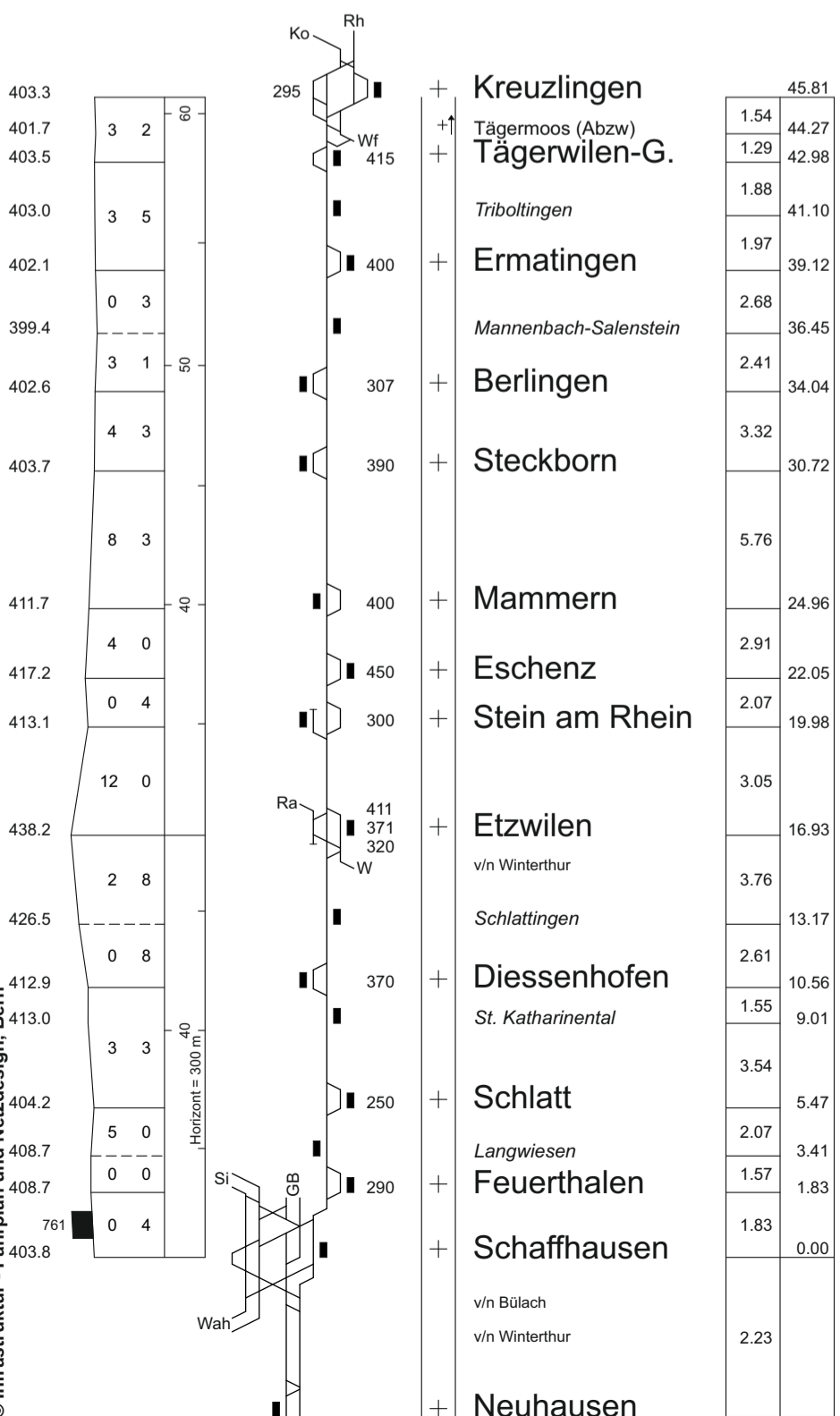

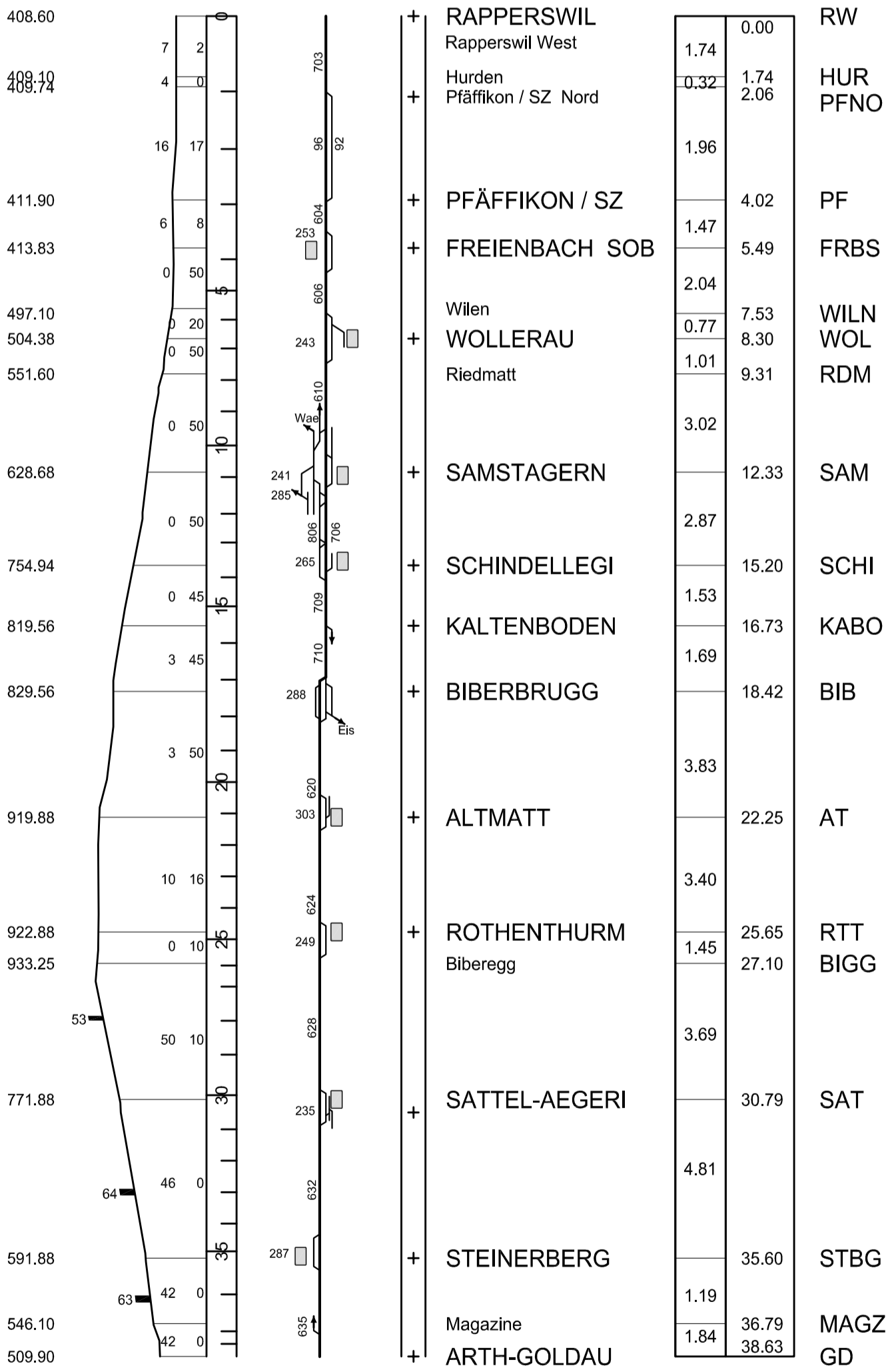
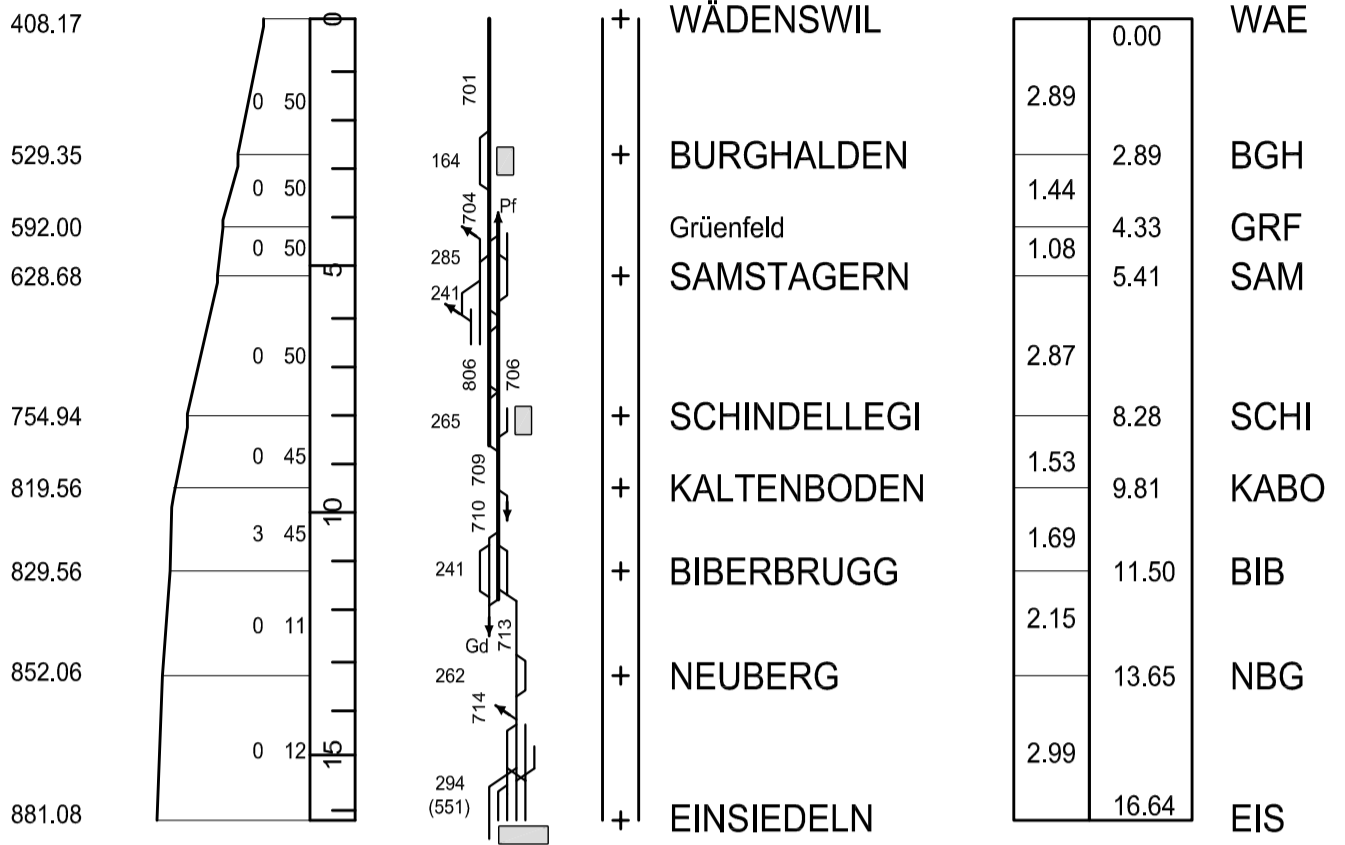

Höhen über Meer
RPN=373.60
Meter

Längenprofil

Grösstes Gefälle
% Grösste Steigung
Kilometrierung

Stationslage,
Abzweigungen,
Längste Ausweichgleise
Streckengleisbezeichnung

Blockstationen

Entfernung zwischen
den Betriebspunkten
Entfernung vom
Ausgangspunkt
km

SOB SÜDOSTBAHN

79

14. Dez. 2014 - 12. Dez. 2015

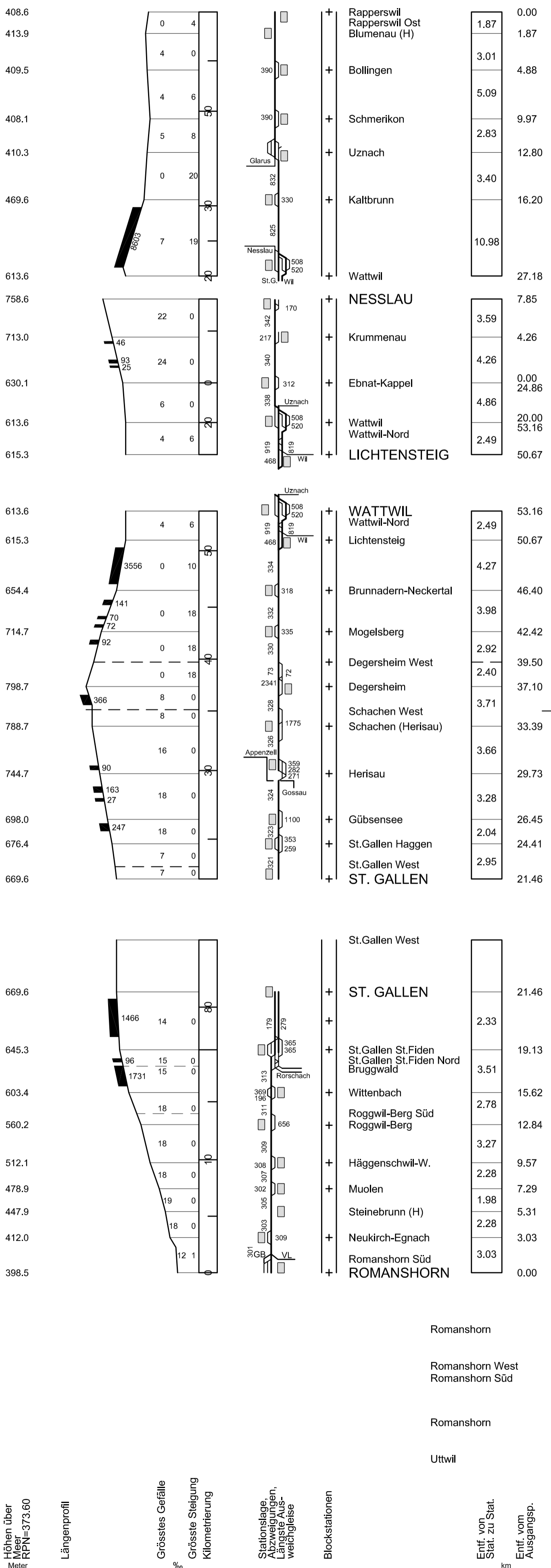

Höhen über Meer
RPN=373.60
Meter

Längenprofil

Grösstes Gefälle
Grösste Steigung
Kilometrierung

Stationslage,
Abzweigungen,
Längste Aus-
weichgleise

Blockstationen

Entf. von Stat. zu Stat.
Entf. vom Ausgangsp.
km

Romanshorn

Romanshorn West
Romanshorn Süd

Romanshorn

Uttwil