

Basel Bad Bf Basel SBB Pfb	
GWb	
P2B	
Hauptbahn	
70 <100 >	
4404	
1.6	
5.1	3.5

BAV 520

Basel Bad Bf Basel Bad Rbf(GR A)	
	P2B
	Hauptbahn
	60
	4405
2.9	0.3
2.8	3.1
0.8	0.4
2.6	0.4
2.2	

BAV 508 / 1

BAV 508 / 2

Basel Bad Rbf Weil (Rh) - Haltingen	
GWb	
L2B und P2B	
Hauptbahn	
130 <160 >	
4000	180
2.0	1.1
2.8	2.3
2.0	
2.8	2.3

BAV 521 / 1

Basel Bad Rbf Weil (Schlaufe)	
P2B	
Hauptbahn	
60	
4411	
2.7	
3.5	0.8

BAV 521 / 2

Basel Bad Rbf Weil (Sig N10)	
P2B	
Hauptbahn	
60	
4415	
1.3	
0.0	1.3

BAV 521 / 3

Basel Bad Bf
BR Einf SBB Pfb

Basel Bad Bf
BR Rbf -Gr-L
Basel Rbf LGr
BR Rbf -Gr-C
BR Rbf -Gr-A

Basel Bad Bf
Weil (Rhein) LGr
Weil am Rhein
Haltingen

BR Rbf -Gr-A
Weil am Rhein

BR Rbf -Gr-A
Weil am Rhein

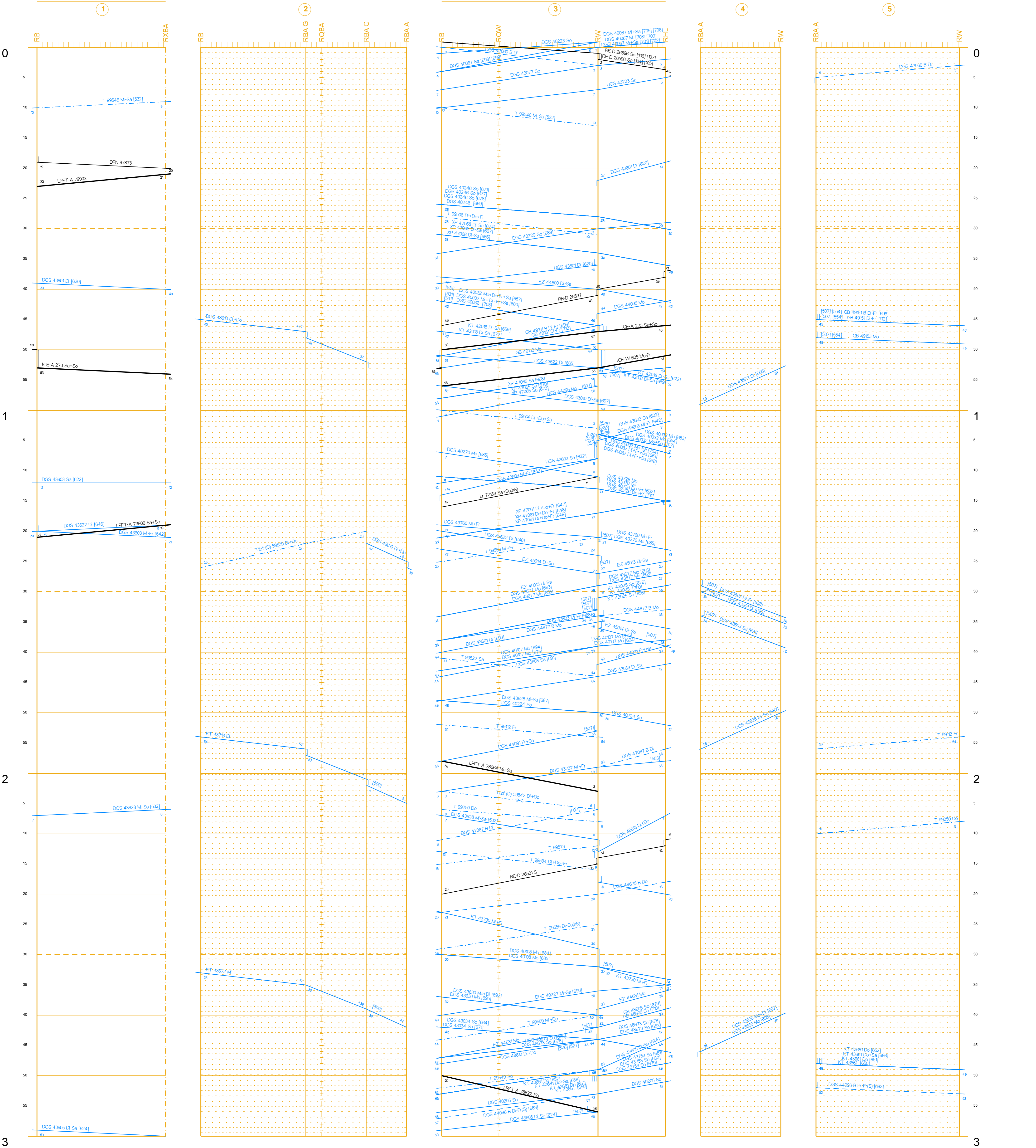

[104] 2.8.15 - 28.9.15 So	[500] Grenzgangsbehandlung	[600] 2.8.15 - 31.8.15 So	[650] 2.8.15 - 10.8.15 Do	[660] 2.8.15 - 10.8.15 Do+Fr	[670] 1.9.15 - 3.10.15 Di-Sa	[680] 2.8.15 - 6.9.15 So	[690] 2.8.15 - 10.8.15 Mi-Sa	[700] 2.8.15 - 9.8.15 Di	[710] 11.8.15 - 3.10.15 So	[720] 2.8.15 - 9.8.15 Di	[730] 11.8.15 - 27.8.15, 28.8.15
[105] 2.8.15 - 25.9.15 Sa	[503] gegenseitiger Ausschluss mit Zug	[602] 2.8.15 - 30.8.15 Sa	[653] 11.8.15 - 6.9.15 Mo	[663] 2.8.15 - 8.8.15 Mo	[673] 12.8.15 - 8.9.15 Sa	[683] 11.8.15 - 3.10.15 So	[693] 31.8.15 - 3.10.15 So	[703] 2.8.15 - 9.8.15 Mi	[713] 11.8.15 - 3.10.15 Di+Fr	[723] 2.8.15 - 10.8.15 So	[733] 2.8.15 - 10.8.15 So
[106] 27.8.15 - 3.10.15 So	<4372>	[604] 2.8.15 - 30.8.15 Di-Sa	[654] 7.8.15 - 3.10.15 So	[664] 8.8.15 - 3.10.15 So	[674] 2.8.15 - 10.8.15 Di-Sa	[684] 31.8.15 - 3.10.15 So	[694] 31.8.15 - 3.10.15 Mi	[704] 10.8.15 - 7.8.15 Do+Fr	[714] 11.8.15 - 27.8.15, 28.8.15	[724] 2.8.15 - 10.8.15 So	[734] 2.8.15 - 10.8.15 So
[107] 26.8.15 - 3.10.15 Sa	[507] Zupersonalwechsel	[605] 2.8.15 - 30.8.15 Mi+Fr	[655] 8.8.15 - 3.10.15 Mo	[665] 31.8.15 - 3.10.15 Di	[675] 2.8.15 - 11.8.15 Mo	[685] 31.8.15 - 3.10.15 So	[695] 31.8.15 - 3.10.15 Mi	[705] 10.8.15 - 7.8.15 Do+Fr	[715] 11.8.15 - 27.8.15, 28.8.15	[725] 2.8.15 - 10.8.15 So	[735] 2.8.15 - 10.8.15 So
[108] nach <44631 am 07.04 + 26.05.15	[606] nach <44631 am 07.04 + 26.05.15	[606] 2.8.15 - 30.8.15 Di	[656] 8.8.15 - 1.9.15 So	[666] 8.8.15 - 1.9.15 So	[676] 2.9.15 - 3.10.15 So	[686] 31.8.15 - 3.10.15 So	[696] 31.8.15 - 3.10.15 Mi	[706] 10.8.15 - 7.8.15 Do+Fr	[716] 11.8.15 - 27.8.15, 28.8.15	[726] 2.8.15 - 10.8.15 So	[736] 2.8.15 - 10.8.15 So
[109] <44631 am 07.04 + 26.05.15	[607] <44631 am 07.04 + 26.05.15	[607] 2.8.15 - 30.8.15 Mi+Fr	[657] 7.8.15 - 3.10.15 Mo+Di+Fr+Sa	[667] 7.8.15 - 3.10.15 Mo+Di+Fr+Sa	[677] 11.8.15 - 6.9.15 So	[687] 11.8.15 - 6.9.15 So	[697] 11.8.15 - 6.9.15 So	[707] 10.8.15 - 7.8.15 Do+Fr	[717] 11.8.15 - 27.8.15, 28.8.15	[727] 2.8.15 - 10.8.15 So	[737] 2.8.15 - 10.8.15 So
[110] <44631 am 07.04 + 26.05.15	[608] <44631 am 07.04 + 26.05.15	[608] 2.8.15 - 30.8.15 Di+Do+Fr	[658] 7.8.15 - 3.10.15 Di+Fr+Sa	[668] 2.8.15 - 11.8.15 Sa	[678] 7.8.15 - 3.10.15 So	[688] 11.8.15 - 6.9.15 So	[698] 11.8.15 - 6.9.15 So	[708] 10.8.15 - 7.8.15 Do+Fr	[718] 11.8.15 - 27.8.15, 28.8.15	[728] 2.8.15 - 10.8.15 So	[738] 2.8.15 - 10.8.15 So
[111] nach <44631 am 07.04 + 26.05.15	[609] nach <44631 am 07.04 + 26.05.15	[609] 11.8.15 - 7.9.15 Di+Do+Fr	[659] 2.8.15 - 31.8.15 Di-Sa	[669] verkehrt nur am 9.8.15	[679] 2.8.15 - 10.8.15 So	[689] 11.8.15 - 6.9.15 So	[699] 11.8.15 - 6.9.15 So	[709] 10.8.15 - 7.8.15 Do+Fr	[719] 11.8.15 - 27.8.15, 28.8.15	[729] 2.8.15 - 10.8.15 So	[739] 2.8.15 - 10.8.15 So
[112] 2.8.15 - 30.8.15 Mi-Sa	[610] 2.8.15 - 30.8.15 Mi-Sa	[610] 11.8.15 - 6.9.15 Mo+Di+Fr+Sa	[660] 11.8.15 - 6.9.15 Mo+Di+Fr+Sa	[670] 11.8.15 - 6.9.15 Mo+Di+Fr+Sa	[680] 11.8.15 - 6.9.15 Mo+Di+Fr+Sa	[690] 11.8.15 - 6.9.15 Mo+Di+Fr+Sa	[700] 11.8.15 - 6.9.15 Mo+Di+Fr+Sa	[710] 11.8.15 - 6.9.15 Mo+Di+Fr+Sa	[720] 11.8.15 - 6.9.15 Mo+Di+Fr+Sa	[730] 11.8.15 - 6.9.15 Mo+Di+Fr+Sa	[740] 11.8.15 - 6.9.15 Mo+Di+Fr+Sa
[113] Systemwechsel	[611] Systemwechsel	[611] 11.8.15 - 28.8.15 Do	[661] 11.8.15 - 6.9.15 Di+Fr+Sa	[671] 2.8.15 - 7.8.15 So	[681] 9.9.15 - 3.10.15 So	[691] 9.9.15 - 3.10.15 So	[701] 9.9.15 - 3.10.15 So	[711] 9.9.15 - 3.10.15 So	[721] 9.9.15 - 3.10.15 So	[731] 9.9.15 - 3.10.15 So	[741] 9.9.15 - 3.10.15 So

Basel Bad Bf
Basel SBB Pb

GWB
P2B
Hauptbahn
70 <100 >
4404
1.6
3.5

BAV 520

Basel Bad Bf
Basel Bad Rbf(GR A)

P2B
Hauptbahn
60
4405
0.3
0.8
2.6
0.4
2.2

BAV 508 / 1 BAV 508 / 2

Basel Bad Rbf
Weil (Rh) - Haltingen

GWB
L2B und P2B
Hauptbahn
130 <160 >
4000
180
2.0
2.8
1.1
2.3
2.8
2.3

BAV 521 / 1

Basel Bad Rbf
Weil (Schlaufe)

P2B
Hauptbahn
60
4411
2.7
0.8

Basel Bad Rbf
Weil (Sig N10)

P2B
Hauptbahn
60
4415
1.3
1.3

Basel Bad Bf
BR Einf SBB Pb

Basel Bad Bf
BR Rbf -GR-L
Basel Rbf LGf
BR Rbf -GR-C
BR Rbf -GR-A

Basel Bad Bf
Weil (Rhein) LGf
Weil am Rhein
Haltingen

BR Rbf -GR-A
Weil am Rhein

BR Rbf -GR-A
Weil am Rhein

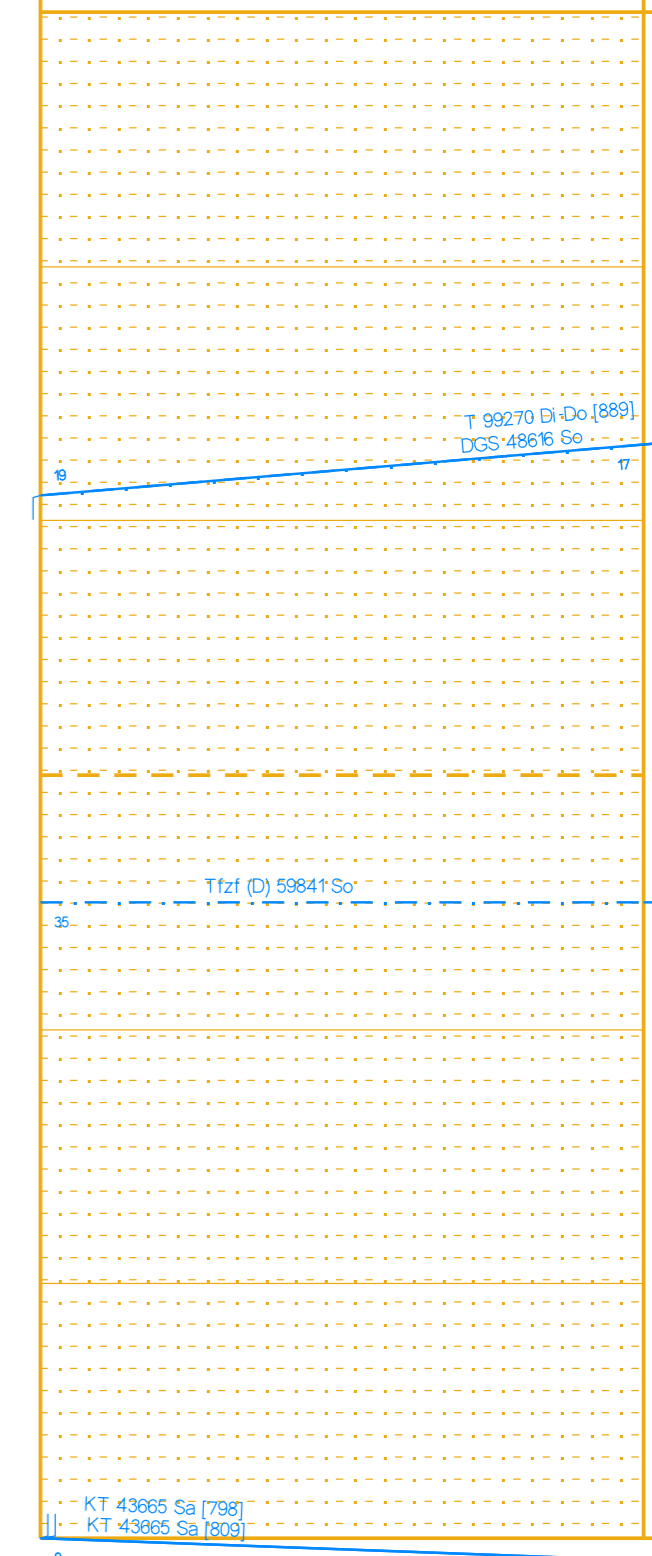
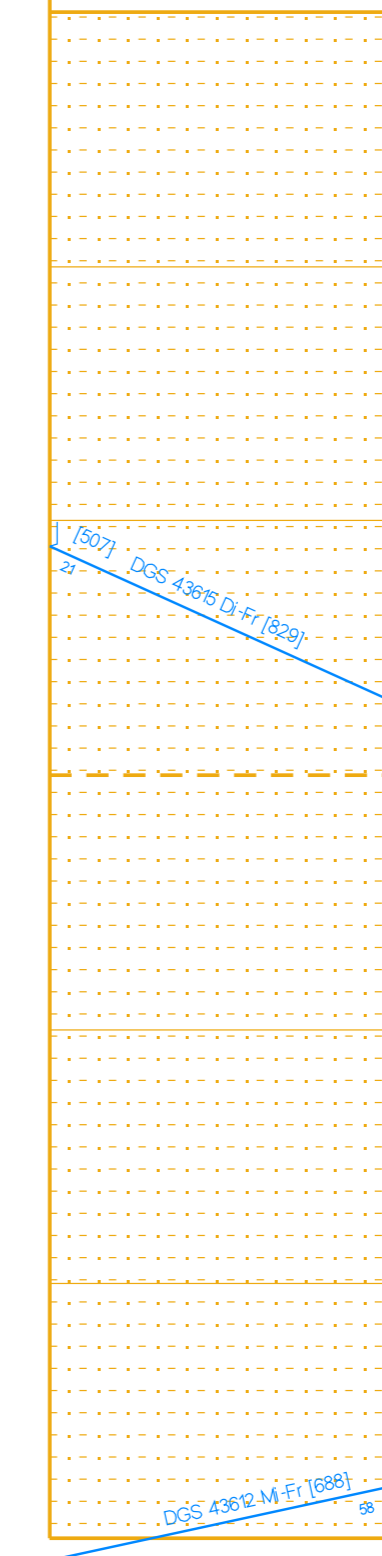
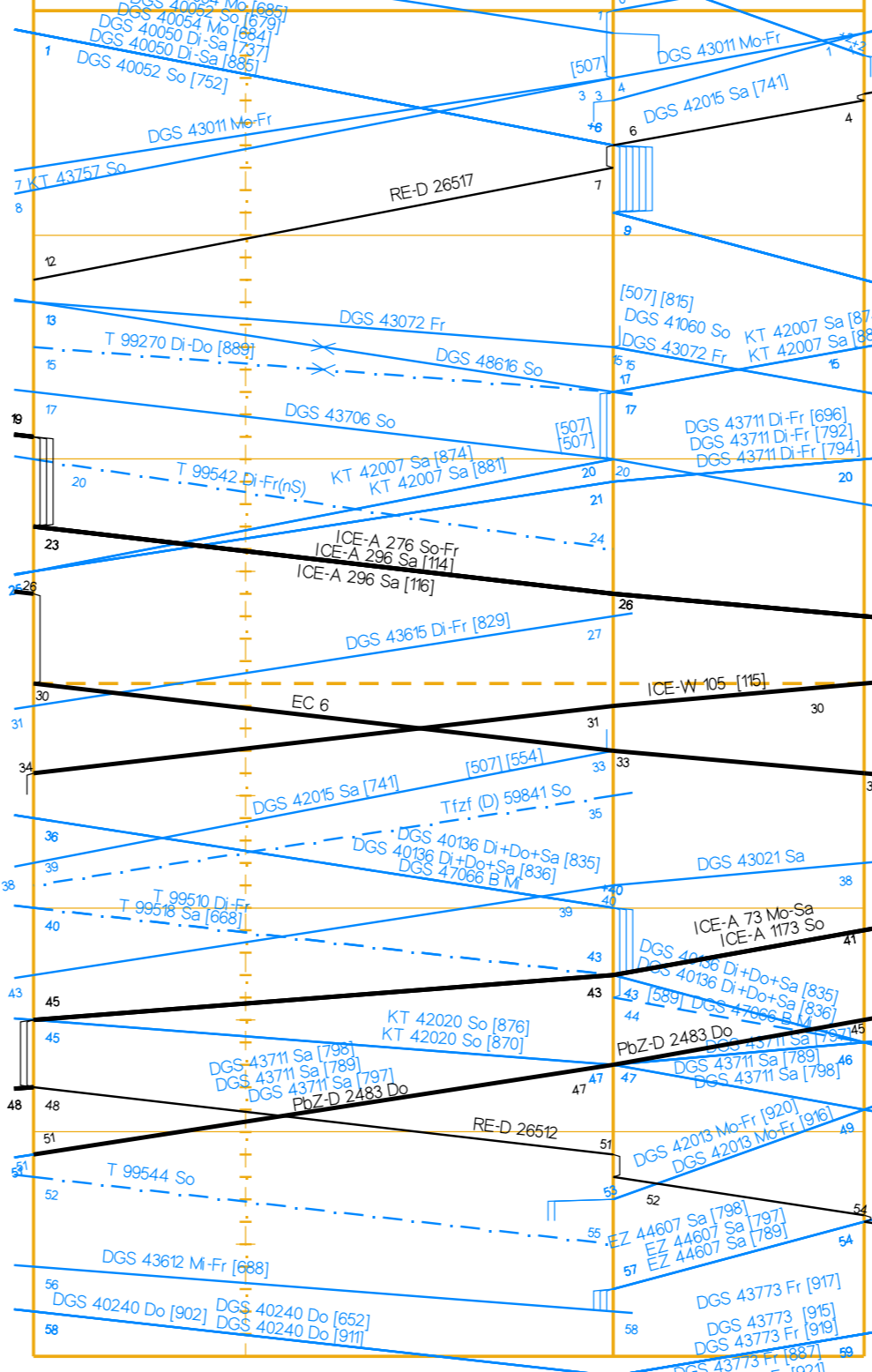
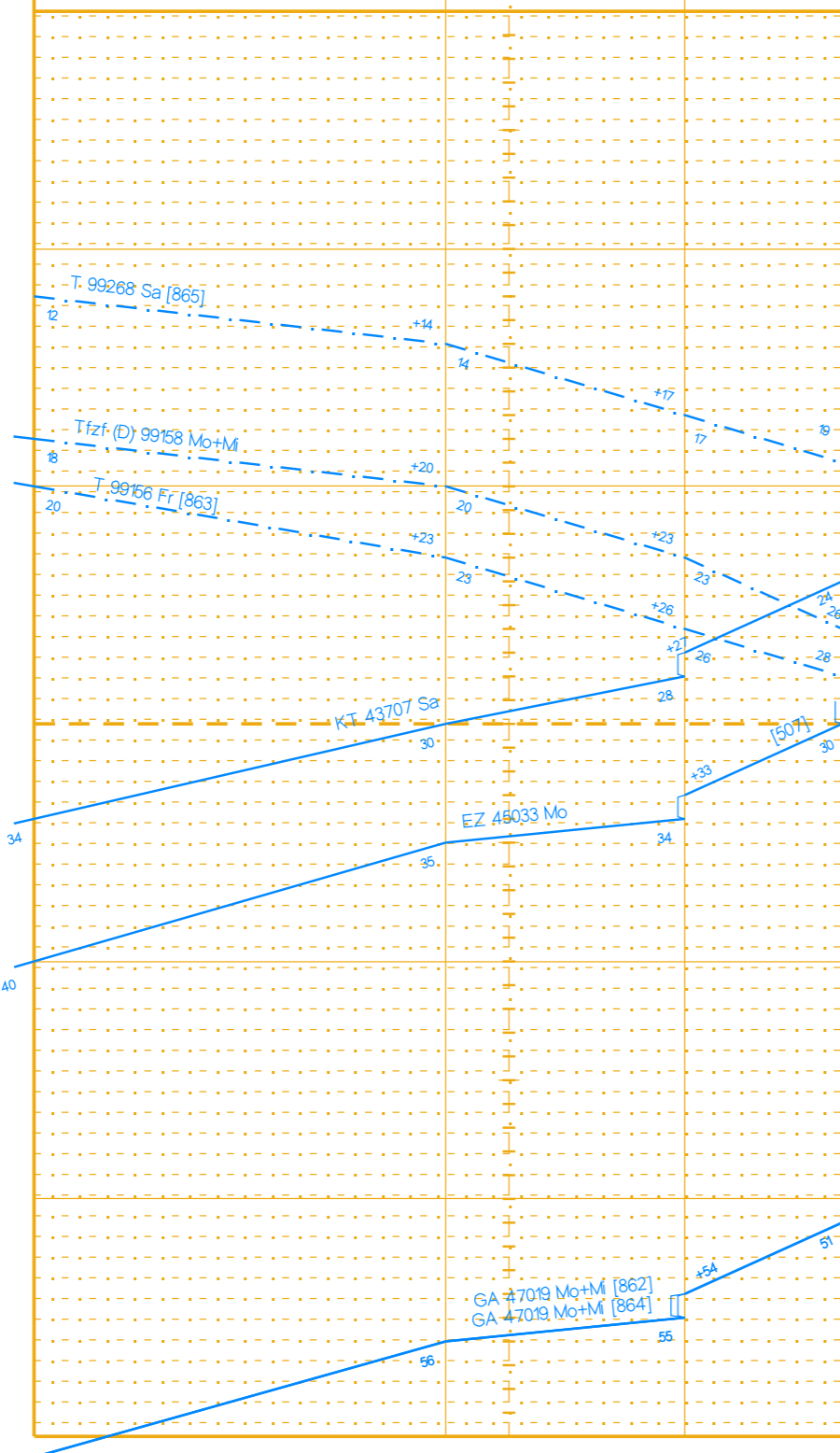
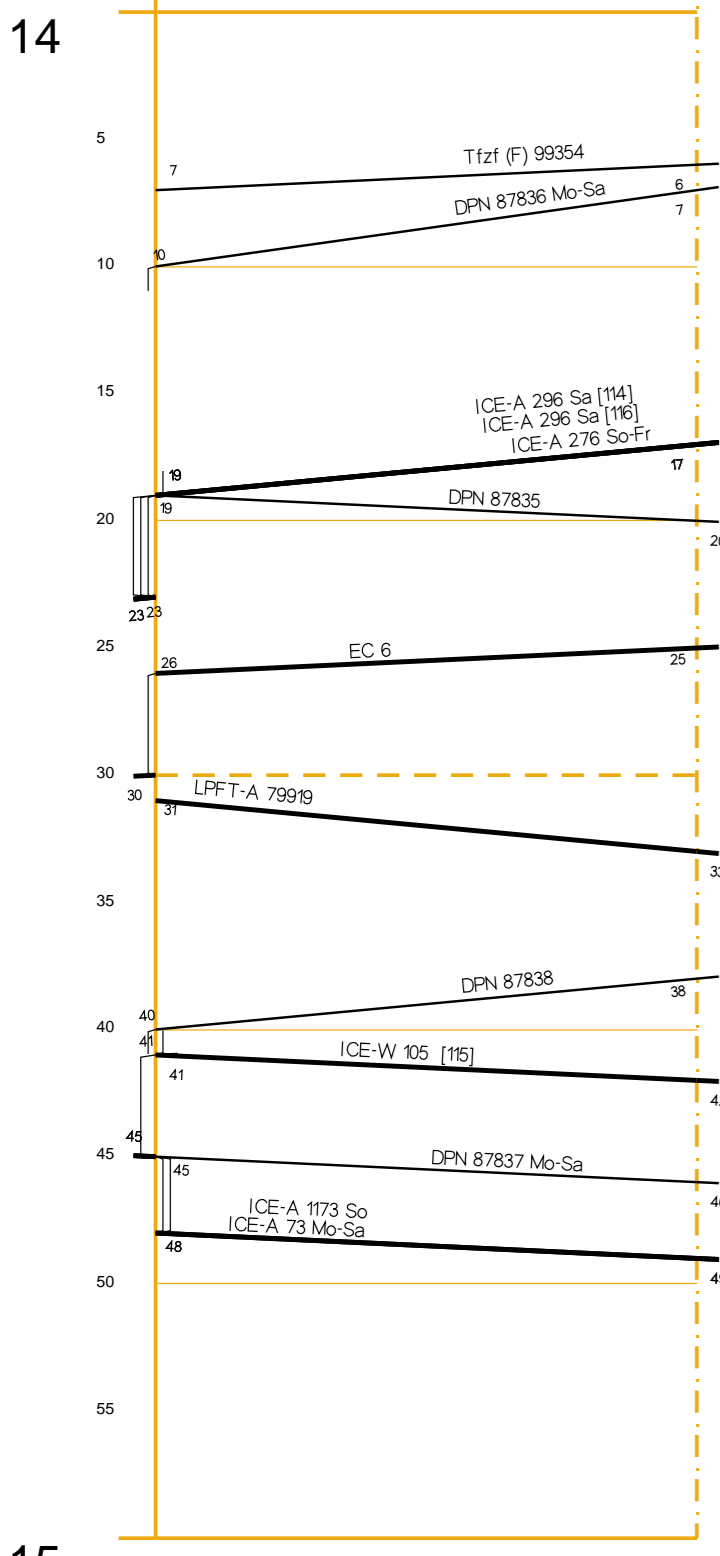
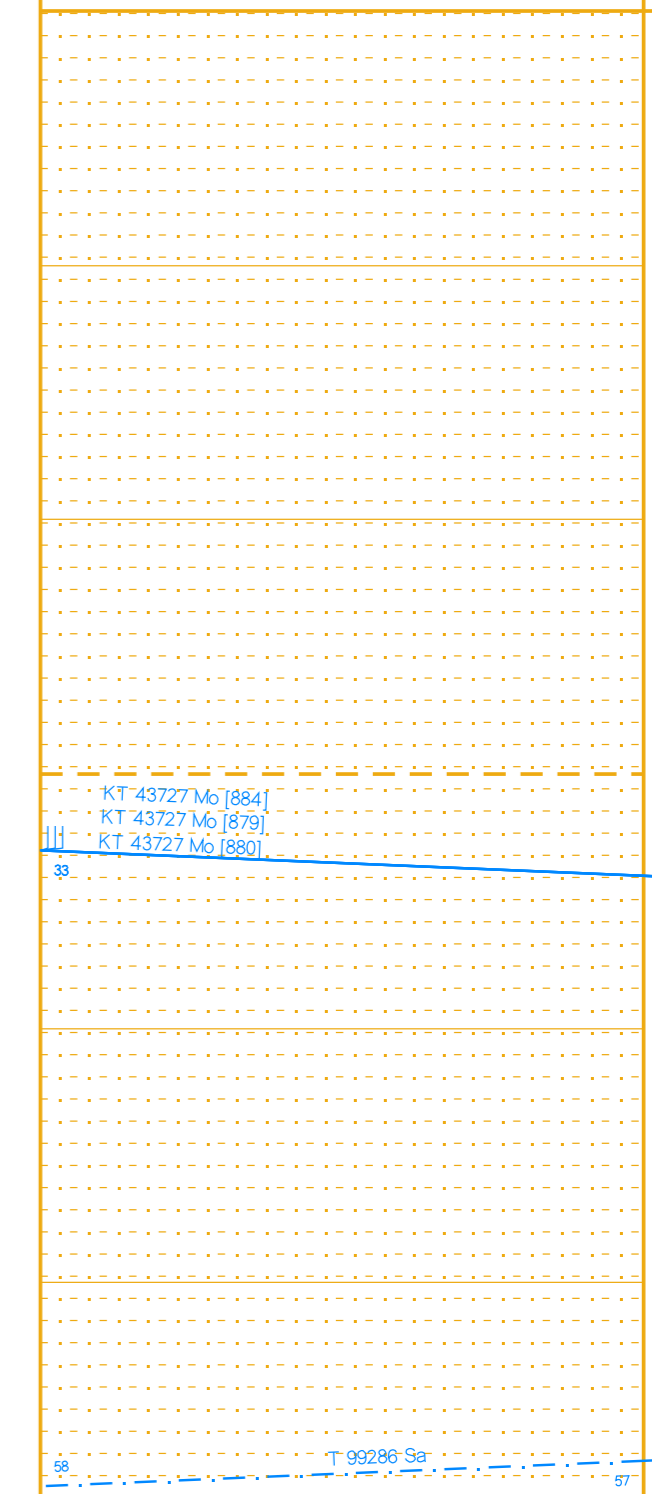
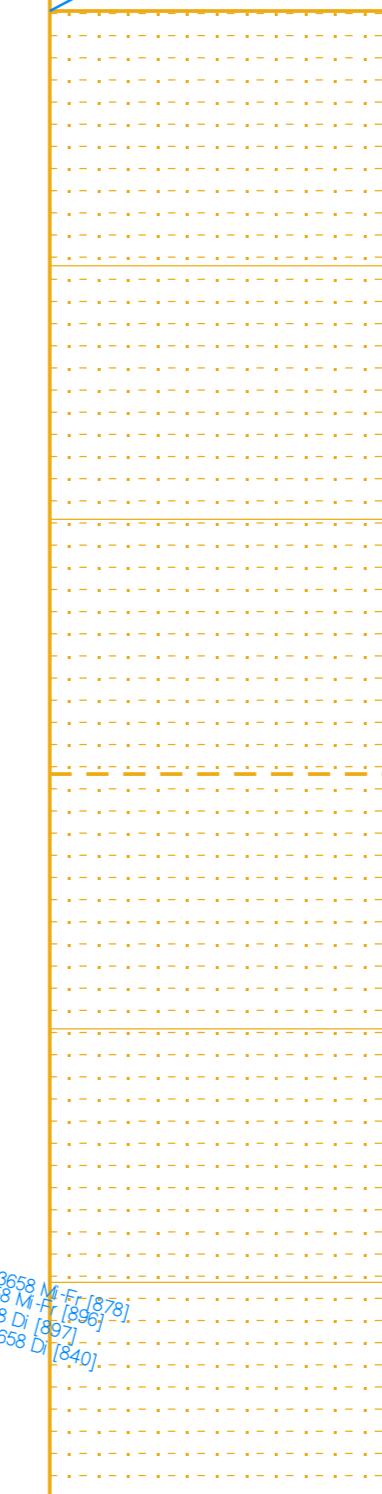
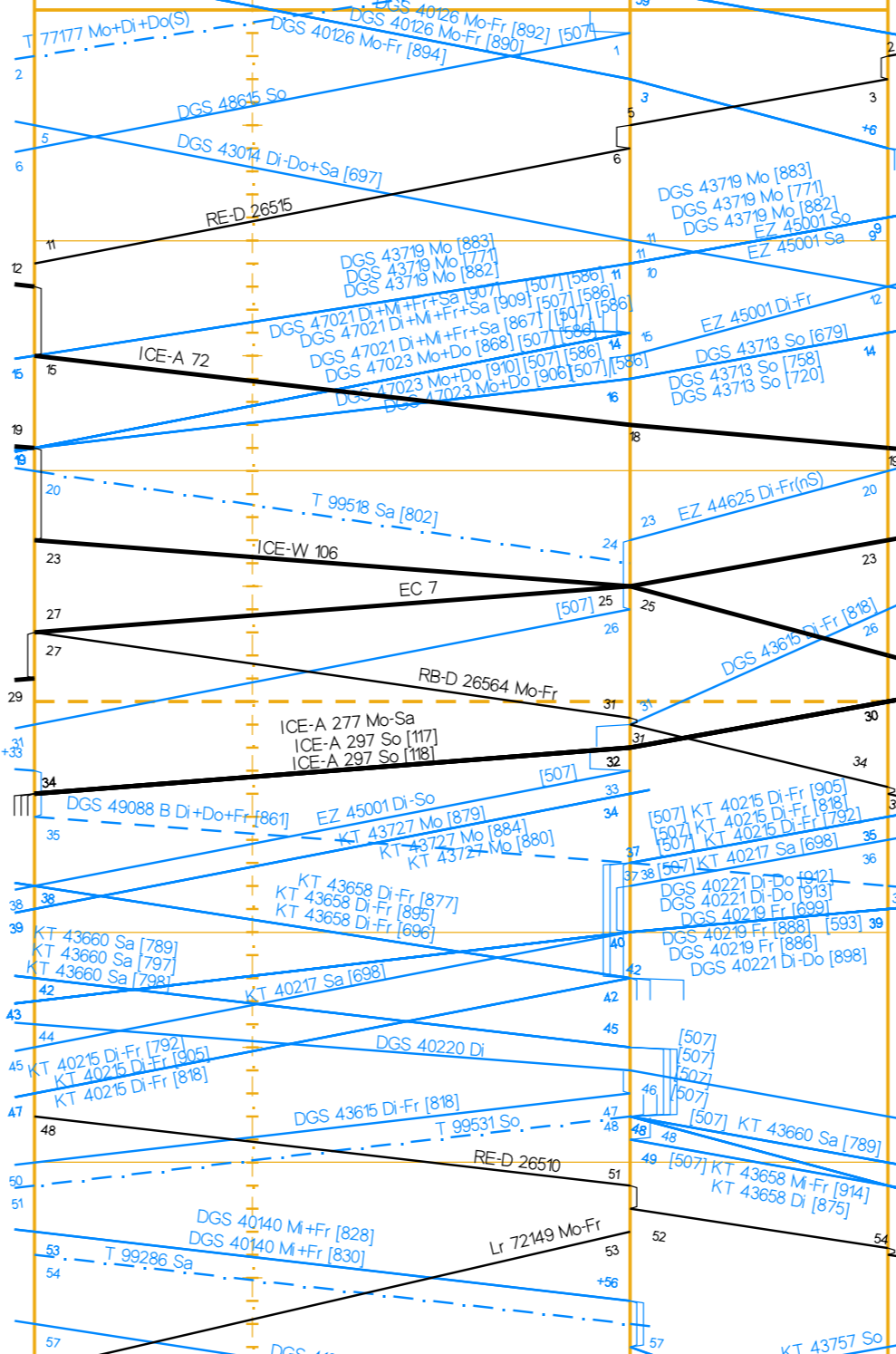
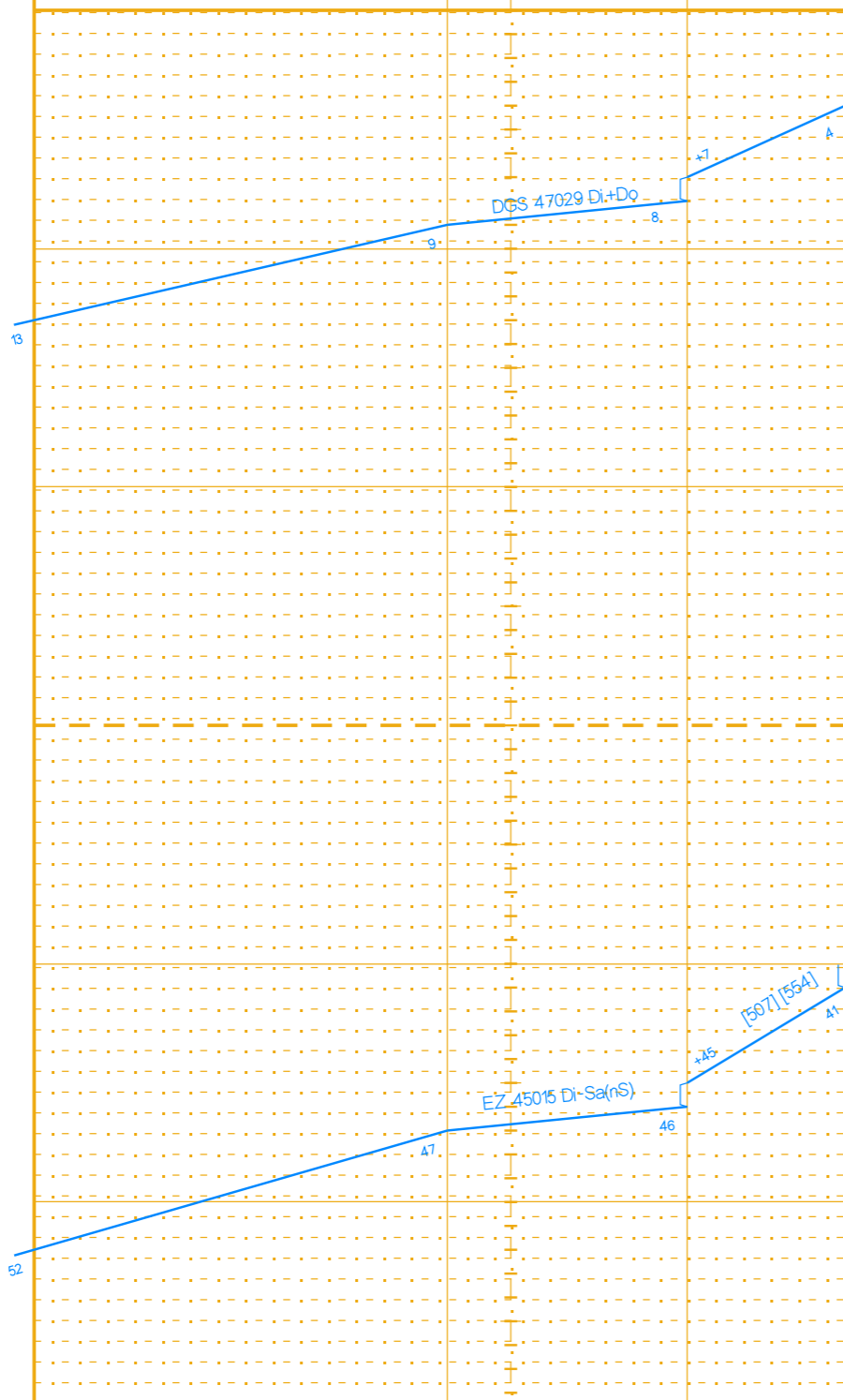
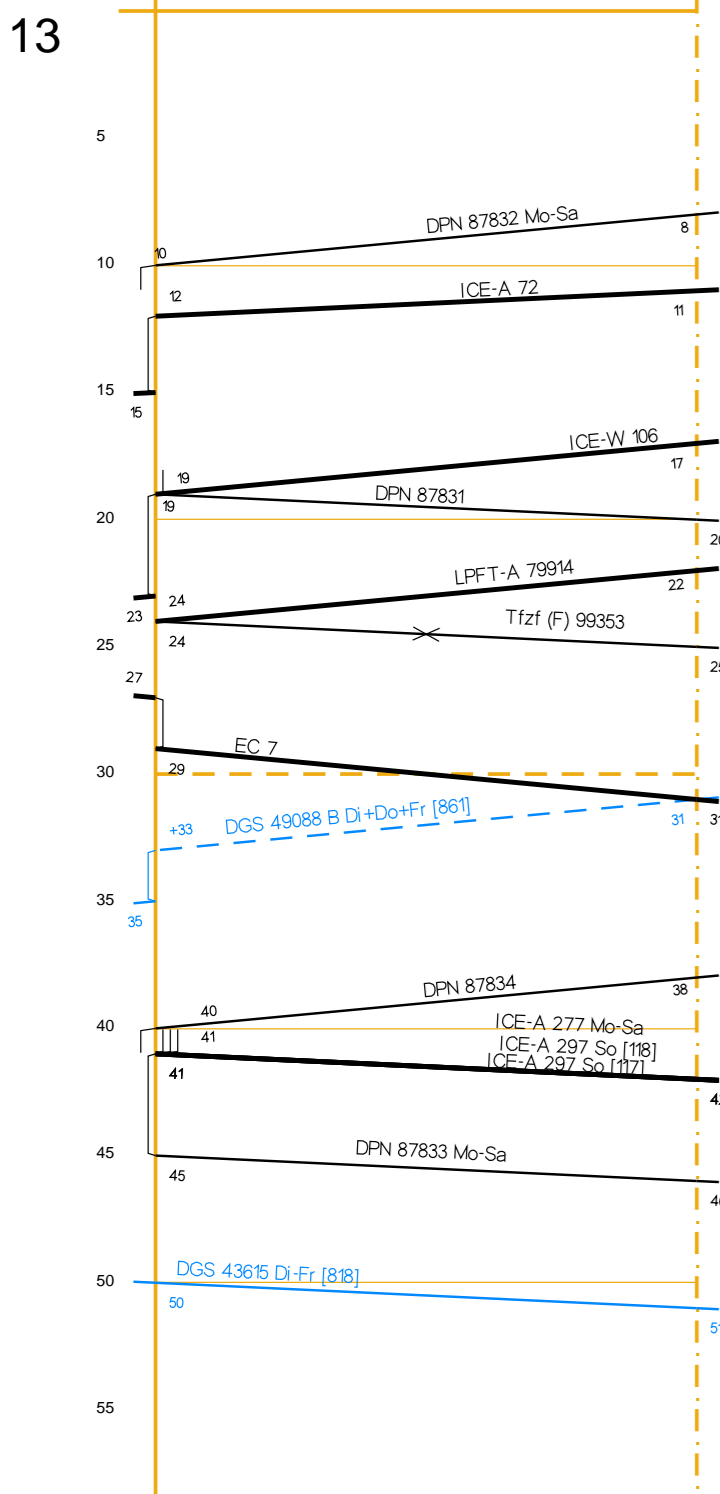
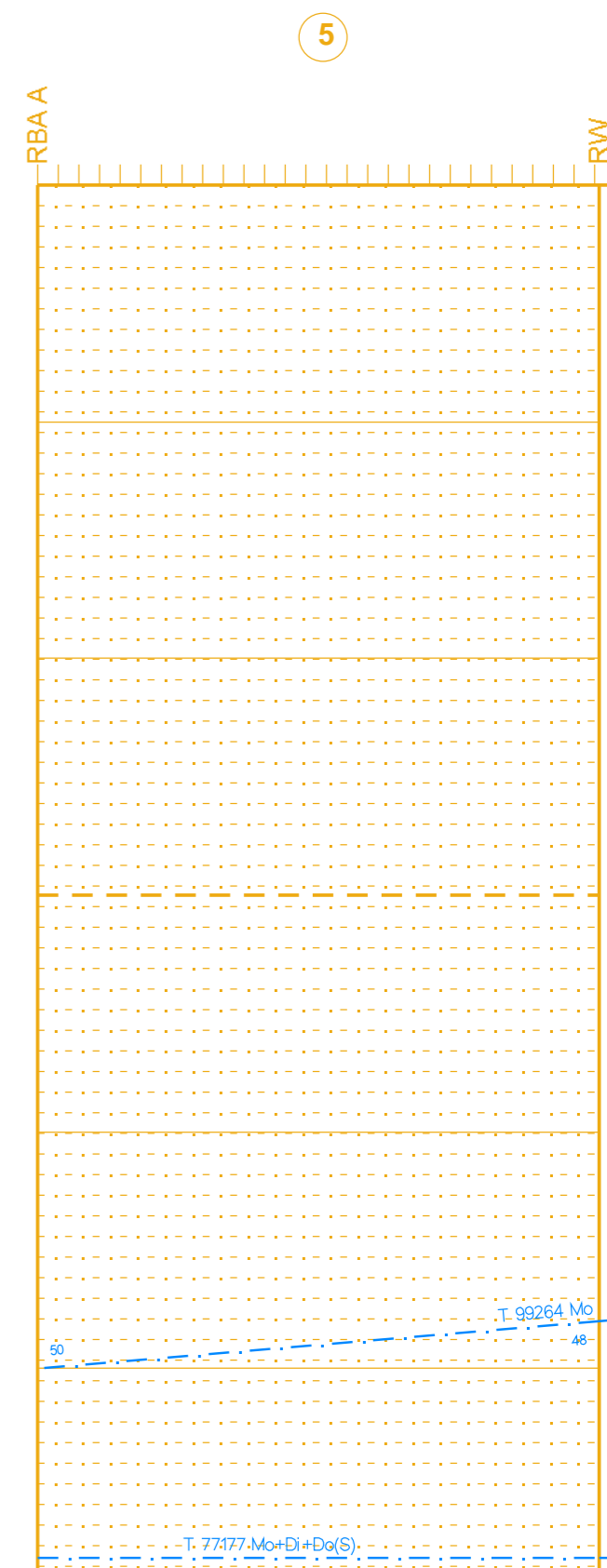
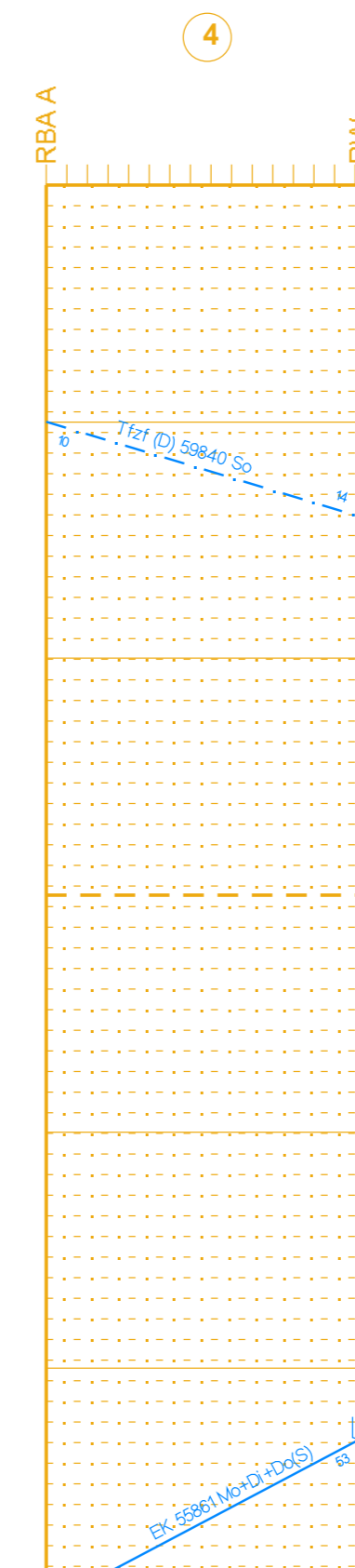
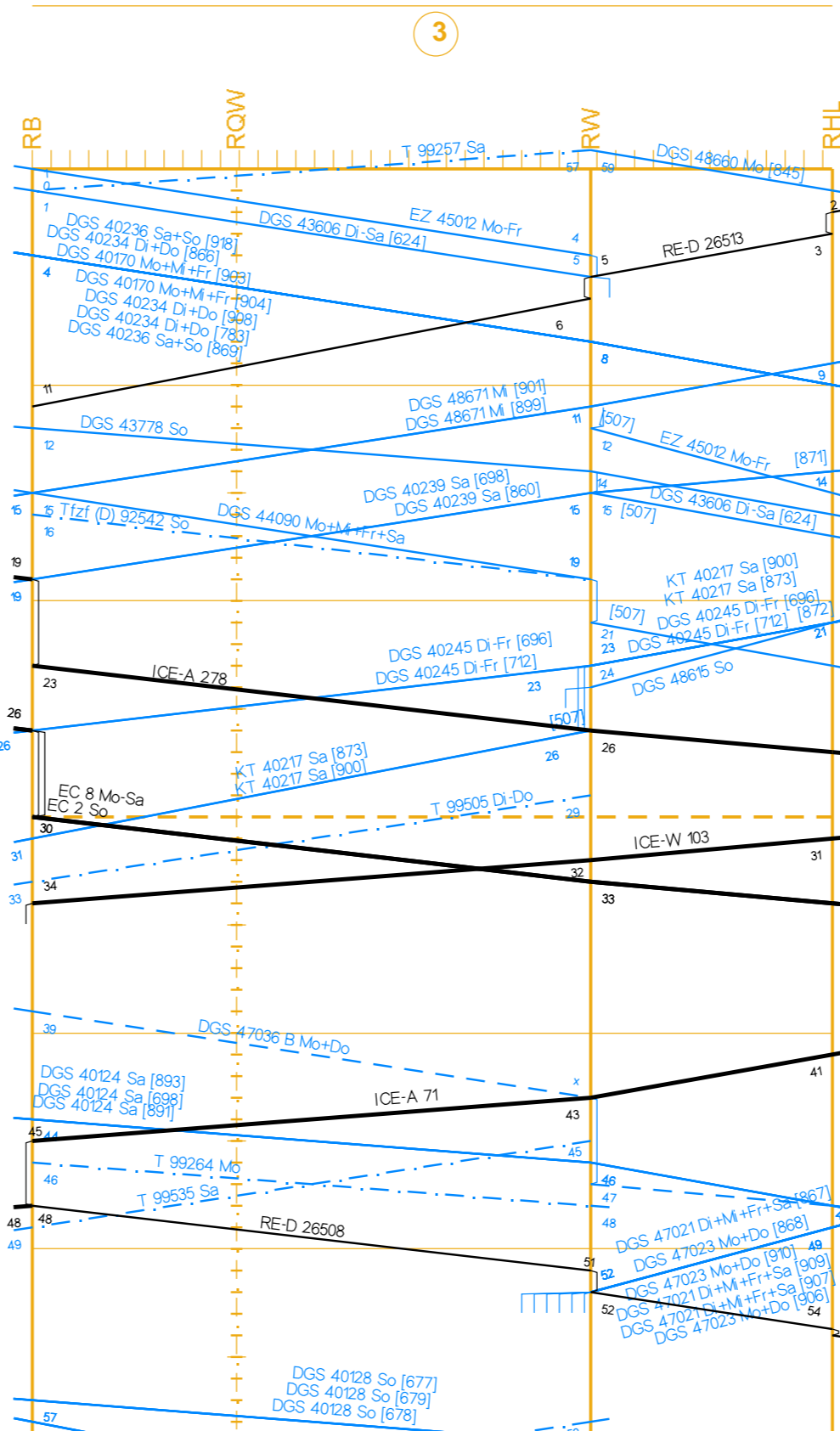
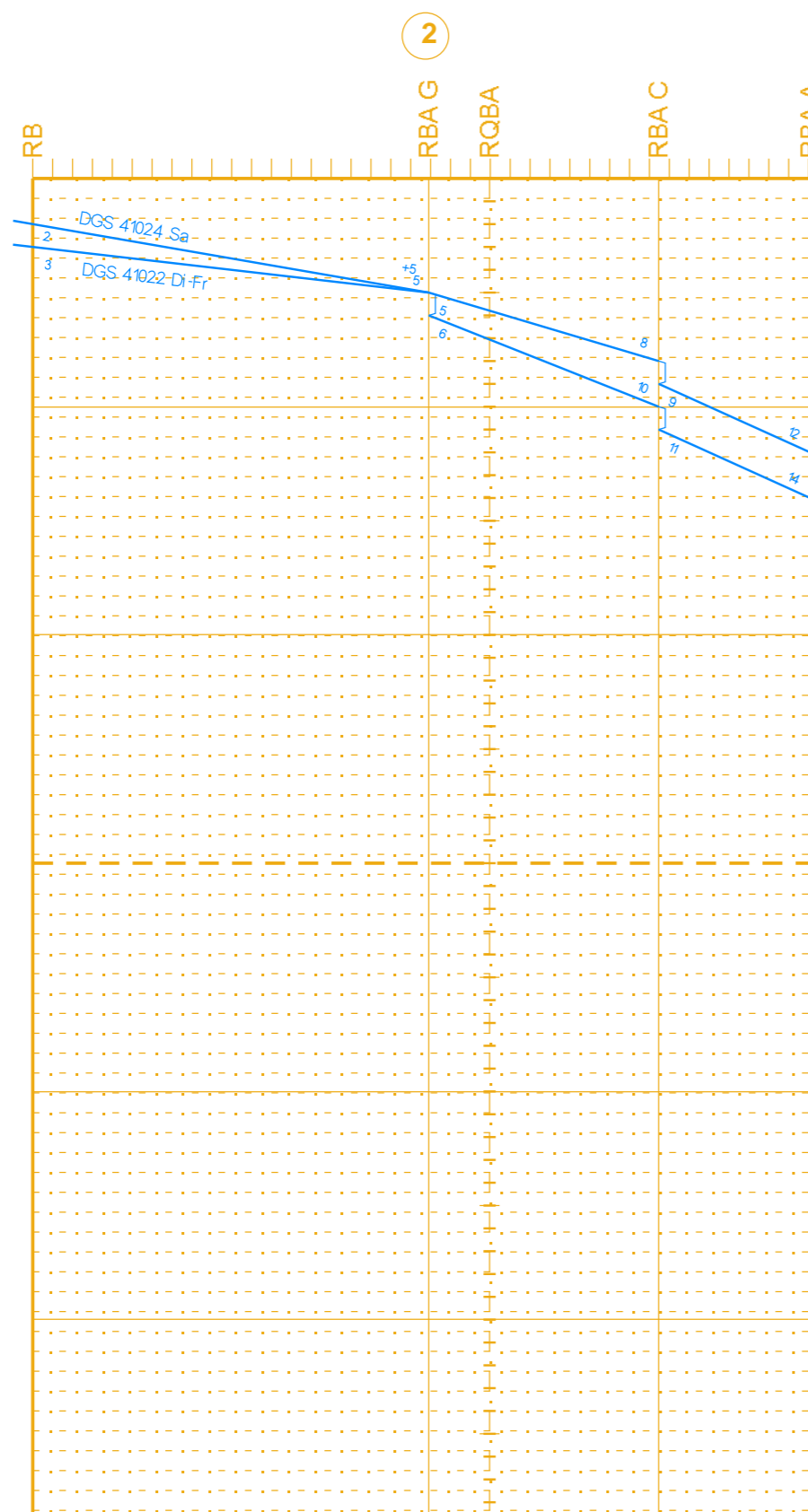
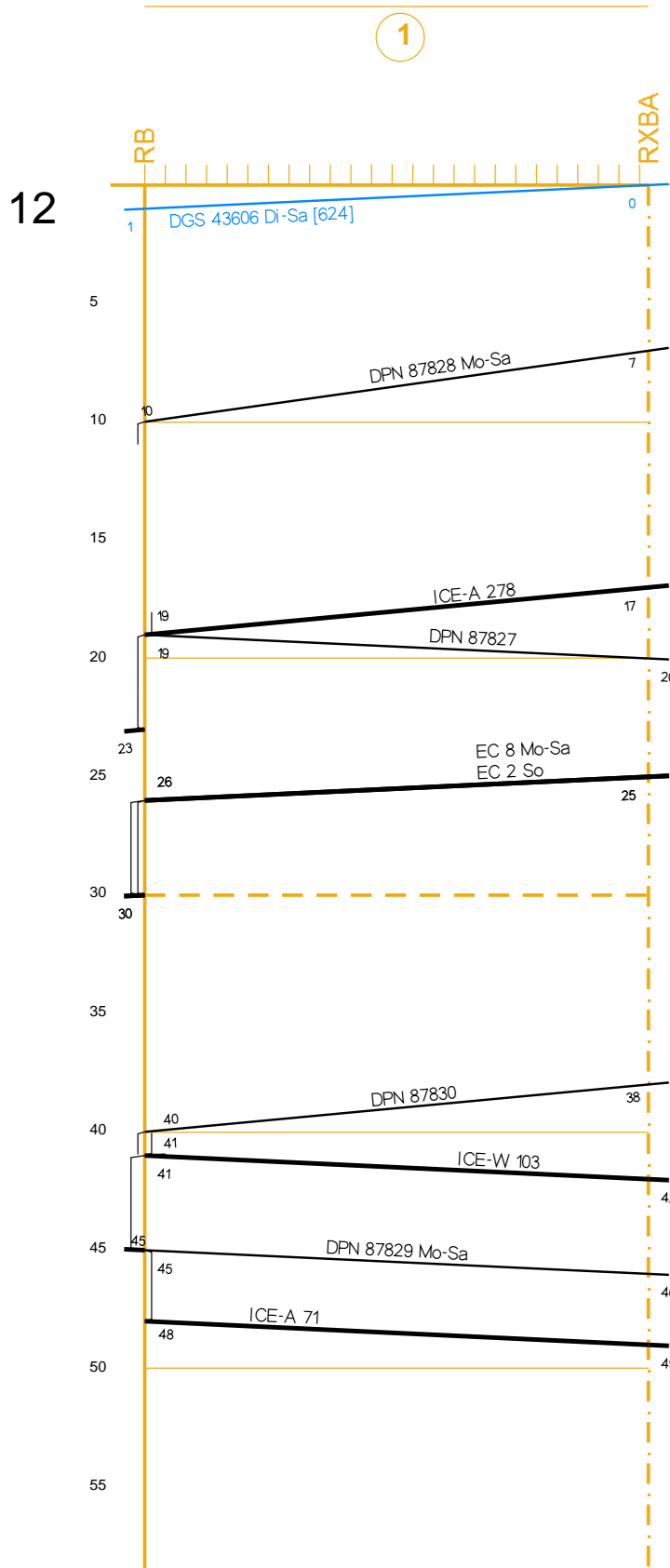

RB RBXA RBAA

[114]	2.8.15 - 28.8.15 Sa	[507]	Zugpersonalauswahl	[878]	7.8.15 - 3.10.15 So
[115]	2.8.15 - 14.8.15	[554]	Systemwechsel	[879]	2.8.15 - 10.8.15 So
[116]	2.8.15 - 3.10.15 Sa	[580]	Systemwechsel	[880]	3.1.15 - 10.15 Mo
[117]	30.8.15 - 3.10.15 So	[590]	Zonen betriebl. bei Bedarf PW	[881]	2.8.15 - 10.8.15 Mo
[118]	2.8.15 - 29.8.15 So	[593]	gegenseitiger Ausschluss mit Zug	[882]	31.8.15 - 7.9.15 So
		[624]	gegenüberzügiger Zug	[883]	2.8.15 - 10.8.15 Mo
		[652]	2.8.15 - 30.8.15 Di-Sa	[884]	gegenüberzügiger Zug
		[668]	2.8.15 - 10.8.15 Do	[885]	2.8.15 - 10.8.15 Mo
		[699]	2.8.15 - 8.8.15 Fr	[886]	2.8.15 - 10.8.15 Do
		[877]	11.8.15 - 8.9.15 So	[887]	11.8.15 - 10.8.15 Di

RB RBAG ROBA RBAC RBAA

[720]	8.8.15 - 3.10.15 So	[797]	10.8.15 - 7.9.15 So	[830]	11.8.15 - 3.10.15 Di+Do
[737]	2.8.15 - 10.8.15 Do	[798]	8.9.15 - 3.10.15 Sa	[840]	7.9.15 - 3.10.15 Di
[741]	2.8.15 - 3.10.15 Sa	[802]	12.8.15 - 3.10.15 Sa	[845]	gegenüberzügiger Zug
[752]	11.8.15 - 3.10.15 So	[809]	1.9.15 - 7.9.15 Sa	[850]	11.8.15 - 3.10.15 Sa
[758]	11.8.15 - 7.9.15 So	[815]	Übernahme von BLS Cargo	[861]	2.8.15 - 30.8.15 Di+Do+Fr
[771]	8.9.15 - 3.10.15 Mo	[816]	2.8.15 - 20.8.15 Di+Fr	[862]	1.9.15 - 3.10.15 Mo
[775]	2.8.15 - 10.8.15 Do	[828]	2.8.15 - 10.8.15 Mi+Fr	[863]	30.8.15 - 3.10.15 Fr
[789]	2.8.15 - 9.8.15 Sa	[829]	31.8.15 - 3.10.15 Di+Fr	[864]	2.8.15 - 31.8.15 Mo+Mi
[792]	8.9.15 - 3.10.15 Di+Fr	[830]	11.8.15 - 3.10.15 Mi+Fr	[865]	30.8.15 - 3.10.15 Sa
[794]	10.8.15 - 7.9.15 Di+Fr	[833]	2.8.15 - 10.8.15 Di+Do+Sa	[866]	7.9.15 - 3.10.15 Do+Do

RB ROW RW RHL

[867]	2.8.15 - 9.8.15 Di+Mi+Fr+Sa	[895]	2.8.15 - 10.8.15 Di	[896]	11.8.15 - 3.10.15 Di-Sa
[868]	2.8.15 - 9.8.15 Mo+Do	[896]	2.8.15 - 31.8.15 So	[899]	8.9.15 - 3.10.15 Fr
[869]	2.8.15 - 10.8.15 Sa+So	[897]	7.9.15 - 3.10.15 Mi+Fr	[900]	2.8.15 - 10.8.15 Fr
[870]	1.9.15 - 3.10.15 So	[898]	7.9.15 - 3.10.15 Mi+Fr	[901]	2.8.15 - 9.8.15 Do
[871]	gegenseitiger Ausschluss mit Zug	[899]	2.8.15 - 29.8.15 Mo	[902]	30.8.15 - 3.10.15 Di+Do
[872]	gegenseitiger Ausschluss mit Zug	[900]	30.8.15 - 11.9.15 Mo	[903]	2.8.15 - 10.8.15 Mo+Fr
[873]	11.8.15 - 30.8.15 Sa	[901]	1.9.15 - 3.10.15 Sa	[904]	7.9.15 - 3.10.15 Sa
[874]	2.8.15 - 31.8.15 Sa	[902]	10.8.15 - 7.9.15 Mo	[905]	7.9.15 - 3.10.15 Sa
		[903]	2.8.15 - 9.8.15 Mo	[906]	11.8.15 - 3.10.15 Mi+Mo+Mi+Fr
		[904]	12.9.15 - 3.10.15 Mo	[907]	11.8.15 - 8.9.15 Do

RBAA RW

[895]	11.8.15 - 3.10.15 Di-Sa	[915]	verkehr nur am 4.9.15
[896]	8.9.15 - 3.10.15 Fr	[916]	3.8.15 - 9.8.15 Mo+Fr
[897]	7.9.15 - 3.10.15 Mo+Do	[917]	20.8.15 - 3.10.15 Mo+Fr
[898]	11.8.15 - 6.9.15 Di+Do	[918]	11.8.15 - 3.10.15 Sa+So
[899]	10.8.15 - 6.9.15 Di+Mi+Fr+Sa	[919]	7.9.15 - 25.9.15 Fr
[900]	20.8.15 - 3.10.15 Fr	[920]	10.8.15 - 7.9.15 Mo+Fr
[901]	2.8.15 - 5.9.15 Mo	[921]	8.9.15 - 3.10.15 Di+Do
[902]	11.8.15 - 6.9.15 Do	[922]	11.8.15 - 31.8.15 Fr
[903]	11.8.15 - 3.10.15 Mi+Mo+Mi+Fr	[923]	10.8.15 - 7.9.15 Di+Do
[904]	2.8.15 - 10.8.15 Mo+Mi+Fr	[924]	2.8.15 - 10.8.15 Mi+Fr

RB RBAG ROBA RBAC RBAA

[720]	8.8.15 - 3.10.15 So	[797]	10.8.15 - 7.9.15 So	[830]	11.8.15 - 3.10.15 Di+Do
[737]	2.8.15 - 10.8.15 Do	[798]	8.9.15 - 3.10.15 Sa	[840]	7.9.15 - 3.10.15 Di
[741]	2.8.15 - 3.10.15 Sa	[802]	12.8.15 - 3.10.15 Sa	[845]	gegenüberzügiger Zug
[752]	11.8.15 - 3.10.15 So	[809]	1.9.15 - 7.9.15 Sa	[850]	11.8.15 - 3.10.15 Sa
[758]	11.8.15 - 7.9.15 So	[815]	Übernahme von BLS Cargo	[861]	2.8.15 - 30.8.15 Di+Do+Fr
[771]	8.9.15 - 3.10.15 Mo	[816]	2.8.15 - 20.8.15 Di+Fr	[862]	1.9.15 - 3.10.15 Mo
[775]	2.8.15 - 10.8.15 Do	[828]	2.8.15 - 10.8.15 Mi+Fr	[863]	30.8.15 - 3.10.15 Fr
[789]	2.8.15 - 9.8.15 Sa	[829]	31.8.15 - 3.10.15 Di+Fr	[864]	2.8.15 - 31.8.15 Mo+Mi
[792]	8.9.15 - 3.10.15 Di+Fr	[830]	11.8.15 - 3.10.15 Mi+Fr	[865]	30.8.15 - 3.10.15 Sa
[794]	10.8.15 - 7.9.15 Di+Fr	[833]	2.8.15 - 10.8.15 Di+Do+Sa	[866]	7.9.15 - 3.10.15 Do+Do

RB ROW RW RHL

[867]	2.8.15 - 9.8.15 Di+Mi+Fr+Sa	[895]	2.8.15 - 10.8.15 Di	[896]	11.8.15 - 3.10.15 Di-Sa
[868]	2.8.15 - 9.8.15 Mo+Do	[896]	2.8.15 - 31.8.15 So	[899]	8.9.15 - 3.10.15 Fr
[869]	2.8.15 - 10.8.15 Sa+So	[897]	7.9.15 - 3.10.15 Mi+Fr	[900]	2.8.15 - 10.8.15 Fr
[870]	1.9.15 - 3.10.15 So	[898]	7.9.15 - 3.10.15 Mi+Fr	[901]	2.8.15 - 9.8.15 Do
[871]	gegenseitiger Ausschluss mit Zug	[899]	2.8.15 - 29.8.15 Mo	[902]	30.8.15 - 3.10.15 Di+Do
[872]	gegenseitiger Ausschluss mit Zug	[900]	30.8.15 - 11.9.15 Mo	[903]	2.8.15 - 10.8.15 Mo+Fr
[873]	11.8.15 - 30.8.15 Sa	[901]	1.9.15 - 3.10.15 Sa	[904]	7.9.15 - 3.10.15 Sa
[874]	2.8.15 - 31.8.15 Sa	[902]	10.8.15 - 7.9.15 Mo	[905]	7.9.15 - 3.10.15 Sa
		[903]	2.8.15 - 9.8.15 Mo	[906]	11.8.15 - 3.10.15 Mi+Mo+Mi+Fr
		[904]	12.9.15 - 3.10.15 Mo	[907]	11.8.15 - 8.9.15 Do

RBAA RW

[895]	11.8.15 - 3.10.15 Di-Sa	[915]	verkehr nur am 4.9.15
[896]	8.9.15 - 3.10.15 Fr	[916]	3.8.15 - 9.8.15 Mo+Fr
[897]	7.9.15 - 3.10.15 Mo+Do	[917]	20.8.15 - 3.10.15 Mo+Fr
[898]	11.8.15 - 6.9.15 Di+Do	[918]	11.8.15 - 3.10.15 Sa+So
[899]	10.8.15 - 6.9.15 Di+Mi+Fr+Sa	[919]	7.9.15 - 25.9.15 Fr
[900]	20.8.15 - 3.10.15 Fr	[920]	10.8.15 - 7.9.15 Mo+Fr
[901]	2.8.15 - 5.9.15 Mo	[921]	8.9.15 - 3.10.15 Di+Do
[902]	11.8.15 - 6.9.15 Do	[922]	11.8.15 - 31.8.15 Fr
[903]	11.8.15 - 3.10.15 Mi+Mo+Mi+Fr	[923]	10.8.15 - 7.9.15 Di+Do
[904]	2.8.15 - 10.8.15 Mo+Mi+Fr	[924]	2.8.15 - 10.8.15 Mi+Fr

Basel Bad Bf Basel SBB Pb	
GWB	
P2B	
Hauptbahn	
70 <100 >	
4404	
1.6	
5.1	
	3.5

BAV 520

Basel Bad Bf Basel Bad Rbf(GR A)	
	P2B
	Hauptbahn
	60
	4415
2.9	4405
2.9	0.3
3.1	
0.8	
2.6	0.4
	2.2

BAV 508 / 1

BAV 508 / 2

Basel Bad Rbf Weil (Rh) - Haltingen	
GWB	
L2B und P2B	
Hauptbahn	
130 <160 >	
4000	180
2.9	
2.9	1.1
2.9	
2.3	
2.9	2.3

BAV 521 / 1

Basel Bad Rbf Weil (Schlaufe)	
P2B	
Nebenbahn	
60	
4411	
2.7	
	0.8

BAV 521 / 2

Basel Bad Rbf Weil (Sig N10)	
P2B	
Hauptbahn	
60	
4415	
1.3	
	1.3

BAV 521 / 3

Basel Bad Bf
BR Einf SBB Pb

Basel Bad Bf
BR Rbf -GR-L
Basel Rbf LGR
BR Rbf -GR-C
BR Rbf -GR-A

Basel Bad Bf
Weil (Rhein) LGR
Weil am Rhein
Haltingen

BR Rbf -GR-A
Weil am Rhein

BR Rbf -GR-A
Weil am Rhein

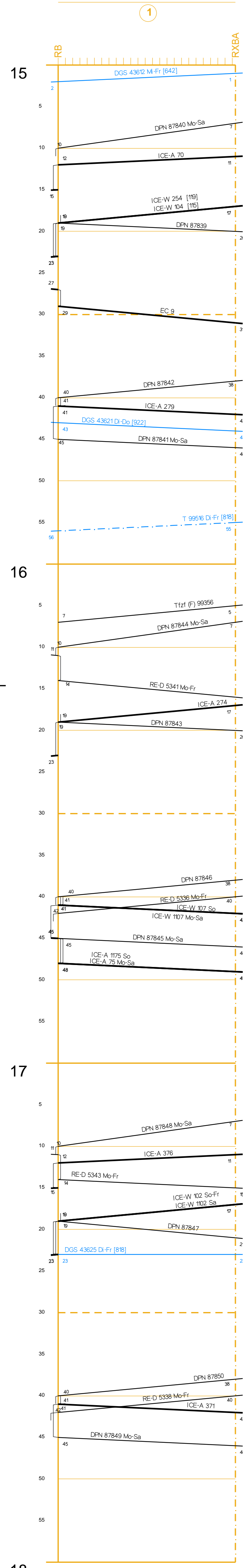

[115]	2.8.15 - 14.8.15	[500]	Grenzübergangsbahn	[891]	31.8.15 - 3.10.15 Sa	[783]	2.8.15 - 10.8.15 Di-Do	[909]	1.9.15 - 7.9.15 Sa	[877]	7.8.15 - 3.10.15 Di-Fr	[916]	3.8.15 - 9.8.15 Mo-Fr	[928]	2.8.15 - 9.8.15 Mo-Fr+Sa	[935]	11.8.15 - 3.10.15 Mi+Fr+So
[118]	3.1.15 - 3.10.15	[507]	Zugpersonalleist.	[897]	nicht: 3.10.15	[789]	2.8.15 - 9.8.15 Sa	[910]	2.8.15 - 9.8.15 Sa	[878]	2.8.15 - 10.8.15 Fr	[917]	8.9.15 - 3.10.15 Mo-Fr	[929]	3.8.15 - 3.10.15 Mo-Fr	[936]	10.8.15 - 6.9.15 Sa
[120]	nicht: 12.8.15, 20.8.15, 9.9.15, 23.9.15	[504]	Systemwechsel	[908]	2.8.15 - 10.8.15 Sa	[791]	10.8.15 - 31.8.15 Sa	[911]	10.8.15 - 31.8.15 Sa	[879]	11.8.15 - 6.9.15 Sa	[918]	26.10.15 - 3.10.15 Fr	[930]	2.8.15 - 9.8.15 Mo-Fr	[937]	11.8.15 - 7.9.15 Di-Do
		[509]	am Mo nach 41665-	[790]	2.8.15 - 10.8.15 Di	[792]	6.9.15 - 3.10.15 Di-Fr	[912]	2.8.15 - 10.8.15 Mo-Fr	[880]	7.8.15 - 3.10.15 Mo-Fr	[919]	7.8.15 - 29.9.15 Fr	[931]	2.8.15 - 9.8.15 Mo-Fr	[938]	2.8.15 - 10.8.15 Mo+Fr
		[642]	2.8.15 - 30.8.15 Mo-Fr	[793]	8.9.15 - 3.10.15 So	[793]	1.9.15 - 7.9.15 Di-Fr	[913]	31.8.15 - 3.10.15 Di-Fr	[881]	7.8.15 - 3.10.15 Sa	[920]	10.8.15 - 7.9.15 Mo-Fr	[932]	8.9.15 - 3.10.15 Di-Sa	[939]	nicht: 3.8.15, 6.8.15, 7.8.15,
		[652]	2.8.15 - 10.8.15 Di	[794]	10.8.15 - 7.9.15 So	[794]	10.8.15 - 7.9.15 Di-Fr	[914]	11.8.15 - 3.10.15 Mi+Fr	[882]	11.8.15 - 6.9.15 Mo-Fr	[921]	11.8.15 - 31.8.15 Fr	[933]	10.8.15 - 6.9.15 So	[940]	nicht: 10.8.15, 19.8.15, 26.8.15,
		[662]	10.8.15 - 7.9.15 Di	[795]	11.8.15 - 3.10.15 So	[795]	2.8.15 - 9.8.15 Di-Fr	[915]	11.8.15 - 3.10.15 Di+Do+Sa	[883]	11.8.15 - 3.10.15 Do	[922]	2.8.15 - 30.8.15 Di-Do	[934]	10.8.15 - 14.8.15 Mo-Mi+Fr+Sa	[941]	11.8.15 - 3.10.15 Mi+Mo-Fr
		[672]	7.9.15 - 3.10.15 So	[796]	11.8.15 - 7.9.15 So	[796]	10.8.15 - 7.9.15 Sa	[916]	11.8.15 - 3.10.15 Mo+Mi	[884]	10.8.15 - 6.9.15 So	[923]	2.8.15 - 31.8.15 Di-Fr	[935]	10.8.15 - 6.9.15 So	[942]	10.8.15 - 6.9.15 Di-Fr
		[679]	2.8.15 - 10.8.15 So	[798]	11.8.15 - 7.9.15 Sa	[798]	6.9.15 - 3.10.15 Sa	[917]	1.9.15 - 3.10.15 Mo+Mi	[885]	1.9.15 - 3.10.15 Mo+Mi	[924]	10.8.15 - 14.8.15 Mo-Mi+Fr+Sa	[936]	10.8.15 - 6.9.15 So	[943]	10.8.15 - 6.9.15 Di-Fr
		[688]	31.8.15 - 3.10.15 Mo-Fr	[799]	7.9.15 - 3.10.15 Mi+Fr	[799]	7.9.15 - 3.10.15 Mi+Fr	[918]	2.8.15 - 9.8.15 So	[886]	2.8.15 - 31.8.15 Mo+Mi	[925]	2.8.15 - 9.8.15 So	[937]	10.8.15 - 6.9.15 So	[944]	10.8.15 - 6.9.15 Di-Fr

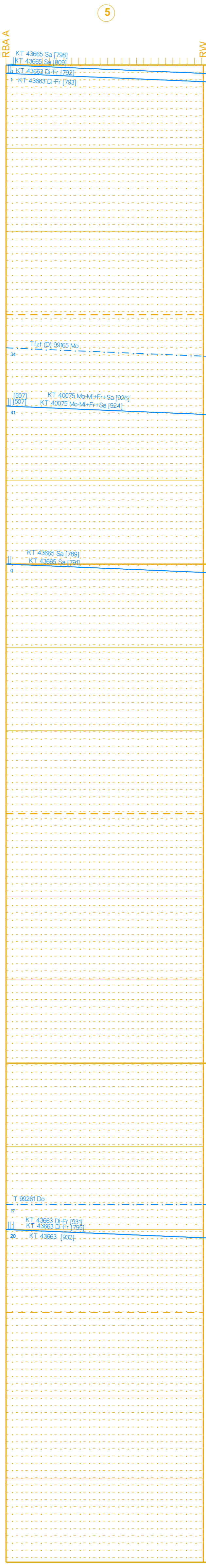
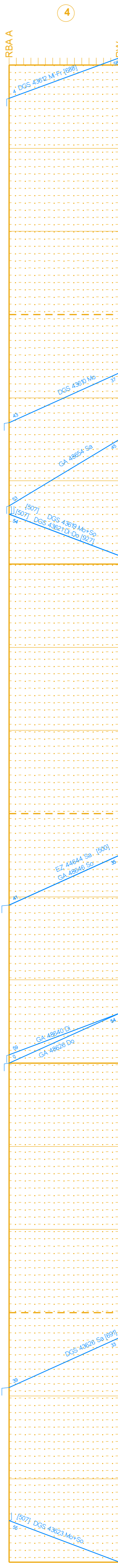
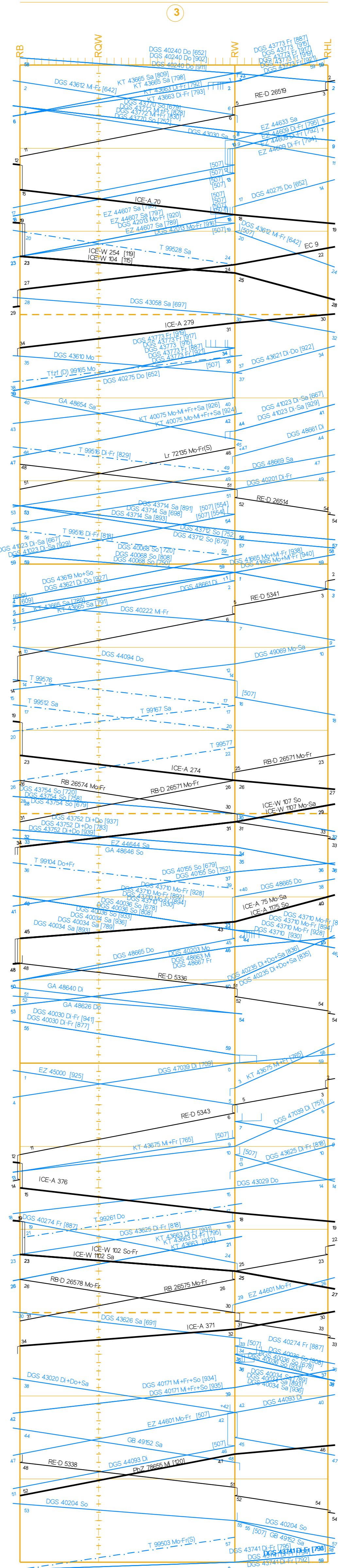
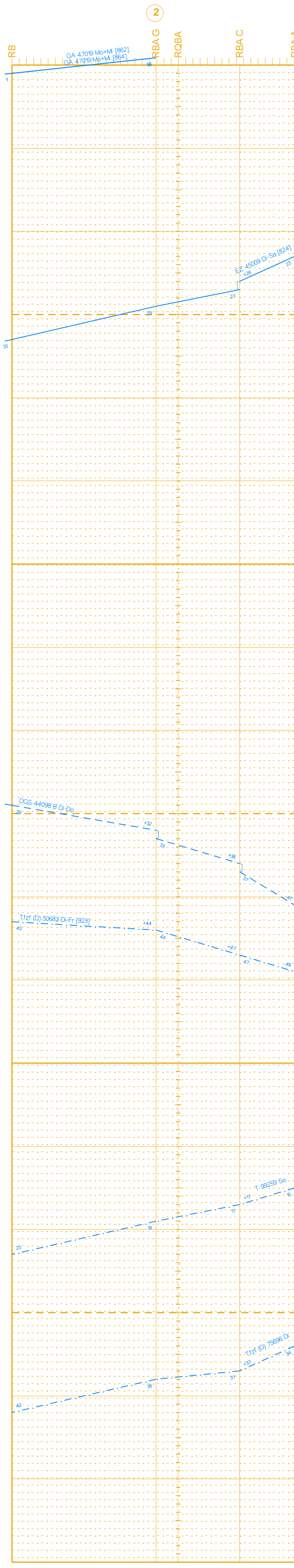

[115]	2.8.15 - 14.8.15	[500]	Grenzübergangsbahn	[891]	31.8.15 - 3.10.15 Sa	[783]	2.8.15 - 10.8.15 Di-Do	[909]	1.9.15 - 7.9.15 Sa	[877]	7.8.15 - 3.10.15 Di-Fr	[916]	3.8.15 - 9.8.15 Mo-Fr	[928]	2.8.15 - 9.8.15 Mo-Fr+Sa	[935]	11.8.15 - 3.10.15 Mi+Fr+So
[118]	3.1.15 - 3.10.15	[507]	Zugpersonalleist.	[897]	nicht: 3.10.15	[789]	2.8.15 - 9.8.15 Sa	[910]	2.8.15 - 9.8.15 Sa	[878]	2.8.15 - 10.8.15 Fr	[917]	8.9.15 - 3.10.15 Mo-Fr	[929]	3.8.15 - 3.10.15 Mo-Fr	[936]	10.8.15 - 6.9.15 Sa
[120]	nicht: 12.8.15, 20.8.15, 9.9.15, 23.9.15	[504]	Systemwechsel	[908]	2.8.15 - 10.8.15 Sa	[791]	10.8.15 - 31.8.15 Sa	[911]	10.8.15 - 31.8.15 Sa	[879]	11.8.15 - 6.9.15 Sa	[918]	26.10.15 - 3.10.15 Fr	[930]	2.8.15 - 9.8.15 Mo-Fr	[937]	11.8.15 - 7.9.15 Di-Do
		[509]	am Mo nach 41665-	[790]	2.8.15 - 10.8.15 Di	[792]	6.9.15 - 3.10.15 Di-Fr	[912]	2.8.15 - 10.8.15 Mo-Fr	[880]	7.8.15 - 3.10.15 Sa	[919]	7.8.15 - 29.9.15 Fr	[931]	2.8.15 - 9.8.15 Mo-Fr	[938]	2.8.15 - 10.8.15 Mo+Fr
		[642]	2.8.15 - 30.8.15 Mo-Fr	[793]	8.9.15 - 3.10.15 So	[793]	1.9.15 - 7.9.15 Di-Fr	[913]	31.8.15 - 3.10.15 Di-Fr	[881]	7.8.15 - 3.10.15 Sa	[920]	10.8.15 - 7.9.15 Mo-Fr	[932]	8.9.15 - 3.10.15 Di-Sa	[939]	nicht: 3.8.15, 6.8.15, 7.8.15,
		[652]	2.8.15 - 10.8.15 Di	[794]	10.8.15 - 7.9.15 So	[794]	10.8.15 - 7.9.15 Di-Fr	[914]	11.8.15 - 3.10.15 Mi+Fr	[882]	11.8.15 - 6.9.15 Mo-Fr	[921]	11.8.15 - 31.8.15 Fr	[933]	10.8.15 - 6.9.15 So	[940]	nicht: 10.8.15, 19.8.15, 26.8.15,
		[662]	10.8.15 - 7.9.15 Di	[795]	11.8.15 - 3.10.15 So	[795]	2.8.15 - 9.8.15 Di-Fr	[915]	11.8.15 - 3.10.15 Di+Do+Sa	[883]	11.8.15 - 3.10.15 Do	[922]	2.8.15 - 30.8.15 Di-Do	[934]	10.8.15 - 14.8.15 Mo-Mi+Fr+Sa	[941]	11.8.15 - 3.10.15 Mi+Mo-Fr
		[672]	7.9.15 - 3.10.15 So	[796]	11.8.15 - 7.9.15 So	[796]	10.8.15 - 7.9.15 Sa	[916]	11.8.15 - 3.10.15 Mo+Mi	[884]	10.8.15 - 6.9.15 So	[923]	2.8.15 - 31.8.15 Di-Fr	[935]	10.8.15 - 6.9.15 So	[942]	10.8.15 - 6.9.15 Di-Fr
		[679]	2.8.15 - 10.8.15 So	[798]	11.8.15 - 7.9.15 Sa	[798]	6.9.15 - 3.10.15 Sa	[917]	1.9.15 - 3.10.15 Mo+Mi	[885]	1.9.15 - 3.10.15 Mo+Mi	[924]	10.8.15 - 14.8.15 Mo-Mi+Fr+Sa	[936]	10.8.15 - 6.9.15 So	[943]	10.8.15 - 6.9.15 Di-Fr
		[688]	31.8.15 - 3.10.15 Mo-Fr	[799]	7.9.15 - 3.10.15 Mi+Fr	[799]	7.9.15 - 3.10.15 Mi+Fr	[918]	2.8.15 - 9.8.15 So	[886]	2.8.15 - 31.8.15 Mo+Mi	[925]	2.8.15 - 9.8.15 So	[937]	10.8.15 - 6.9.15 So	[944]	10.8.15 - 6.9.15 Di-Fr

Basel Bad Bf Basel SBB Pb	
GWB	
P2B	
Hauptbahn	
70 <100 >	
4404	
1.6	
5.1	3.5

BAV 520

Basel Bad Bf Basel Bad Rbf(GR A)	
GWB	
P2B	
Hauptbahn	
60	80
4405	4413
2.9	0.8
2.8	0.6
3.1	0.4
2.6	0.4
2.2	2.2

BAV 508 / 1

BAV 508 / 2

Basel Bad Rbf Weil (Rh) - Haltingen	
GWB	
L2B und P2B	
Hauptbahn	
130 <160 >	160
2.0	2.3
2.8	1.1
2.9	2.3
2.7	2.3
2.9	2.3

BAV 521 / 1

Basel Bad Rbf Weil (Schlaufe)	
GWB	
P2B	
Hauptbahn	
60	
4411	
2.7	
3.5	0.8

BAV 521 / 1

Basel Bad Rbf Weil (Sig N10)	
GWB	
P2B	
Hauptbahn	
60	
4413	
1.3	
0.0	1.3

BAV 521 / 1

Basel Bad Bf
BR Einf SBB Pb

Basel Bad Bf
BR Rbf -Gr-L-
Basel Rbf LGr
BR Rbf -Gr-C-
BR Rbf -Gr-A-

Basel Bad Bf
Weil (Rhein) LGr
Weil am Rhein
Haltingen

BR Rbf -Gr-A-
Weil am Rhein

BR Rbf -Gr-A-
Weil am Rhein

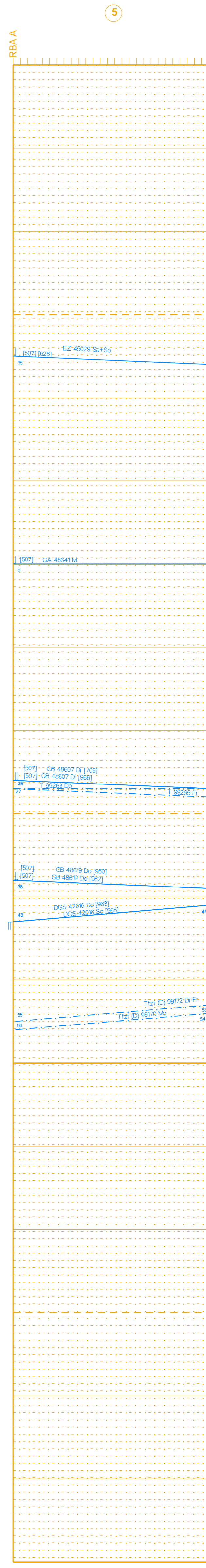
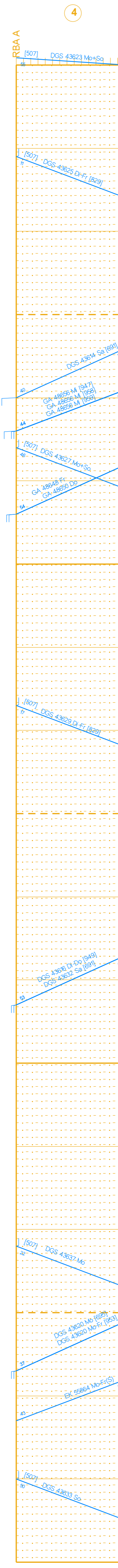
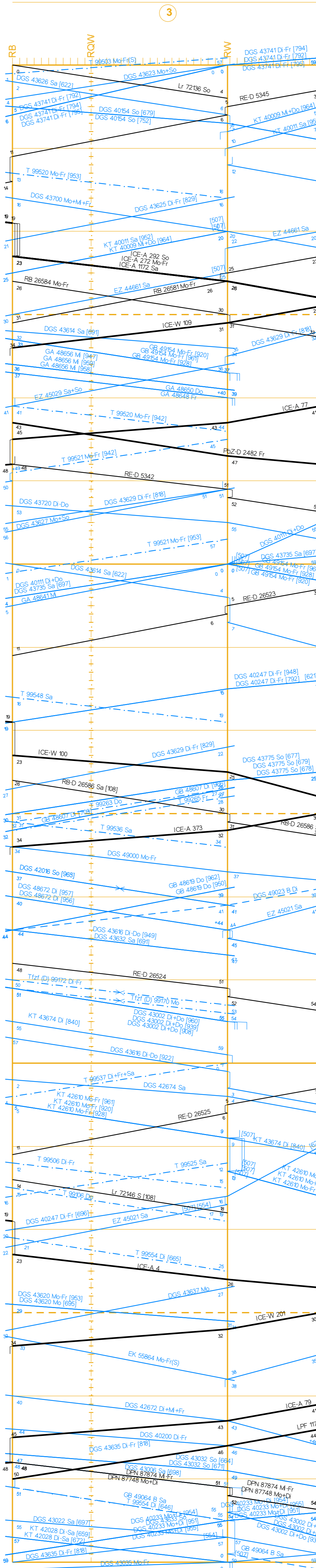
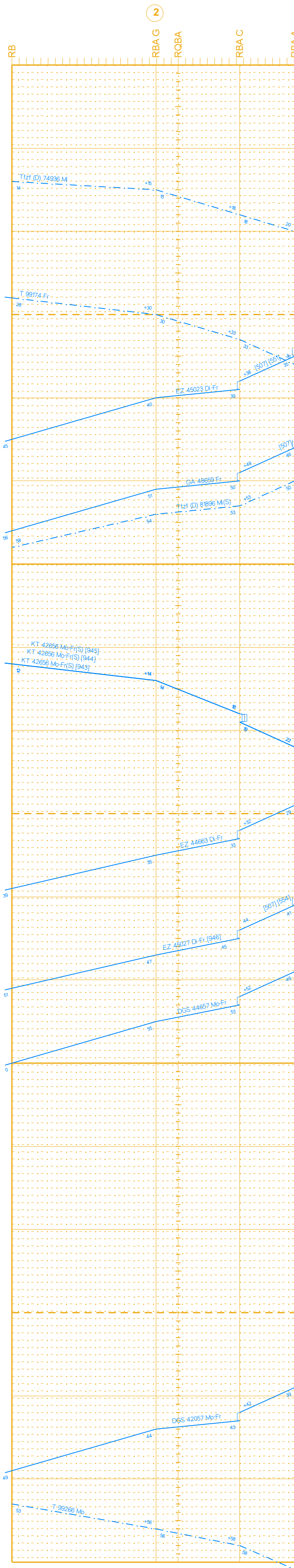
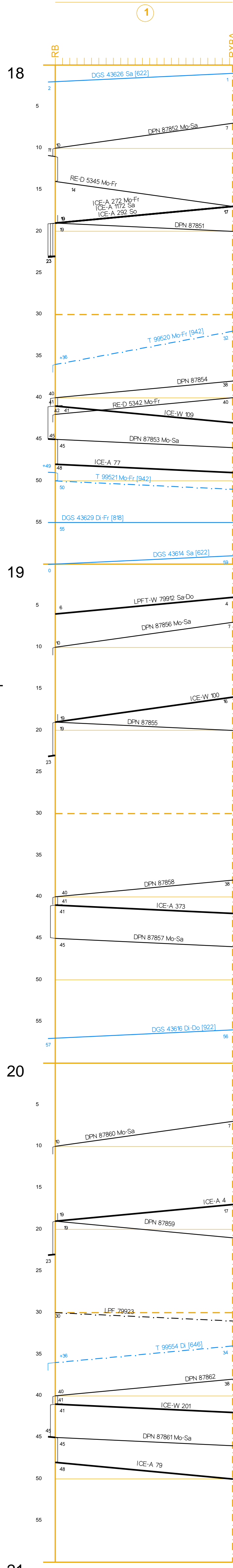

RB	RXBA
[507] Zugpersonalwechsel	[665] 31.8.15 - 3.10.15 Di
[591] Systemwechsel, Bremswechsel	[671] 2.8.15 - 7.8.15 So
[594] Systemwechsel	[672] 1.8.15 - 3.10.15 Di
[651] ortsgemeinlicher Anschluss mit Zug	[673] 11.8.15 - 6.10.15 So
<40247>	[678] 7.8.15 - 3.10.15 So
[652] 2.8.15 - 30.8.15 Sa	[679] 2.8.15 - 10.8.15 Di
[628] Systemwechsel	[691] 31.8.15 - 3.10.15 Sa
[646] 2.8.15 - 30.8.15 Di	[695] 2.8.15 - 30.8.15 Mo
[659] 2.8.15 - 31.8.15 Di-Sa	[696] 2.8.15 - 10.8.15 Di-Fr
[664] 8.8.15 - 3.10.15 So	[697] nicht: 3.10.15

RB	RBA G	ROBA	RBA C	RBA A
[698] 2.8.15 - 10.8.15 Sa	[920] 10.8.15 - 7.9.15 Mo-Fr	[948] 11.8.15 - 7.9.15 Di-Fr	[958] 8.9.15 - 3.10.15 Mo	[968] 10.8.15 - 3.10.15 Di
[709] 2.8.15 - 9.8.15 Di	[922] 2.8.15 - 30.8.15 Di-Do	[949] 31.8.15 - 6.9.15 Di-Do	[969] 2.8.15 - 9.8.15 Mo	[969] 2.8.15 - 9.8.15 Mo
[752] 11.8.15 - 3.10.15 Di	[928] 2.8.15 - 9.8.15 Di-Do	[950] 2.8.15 - 9.8.15 Di-Do	[970] 2.8.15 - 9.8.15 Di-Do	[970] 2.8.15 - 9.8.15 Di-Do
[752] 8.8.15 - 3.10.15 Di-Fr	[939] 8.8.15 - 3.10.15 Mo-Fr	[951] 2.8.15 - 9.8.15 Mo-Fr	[971] 8.8.15 - 3.10.15 Mo-Fr	[971] 8.8.15 - 3.10.15 Mo-Fr
[794] 10.8.15 - 7.9.15 Di-Fr	[942] 2.8.15 - 30.8.15 Mo-Fr	[952] 4.8.15 - 3.10.15 Sa	[972] 10.8.15 - 3.10.15 Di	[972] 10.8.15 - 3.10.15 Di
[795] 2.8.15 - 10.8.15 Di	[943] 2.8.15 - 10.8.15 Mo-Fr	[953] 31.8.15 - 3.10.15 Mo-Fr	[973] 2.8.15 - 10.8.15 Di	[973] 2.8.15 - 10.8.15 Di
[818] 2.8.15 - 30.8.15 Di-Fr	[944] 29.8.15 - 3.10.15 Mo-Fr(S)	[954] 10.8.15 - 7.9.15 Mo+Di	[974] 8.8.15 - 3.10.15 Mo	[974] 8.8.15 - 3.10.15 Mo
[829] 31.8.15 - 3.10.15 Di-Fr	[945] 11.8.15 - 28.8.15 Mo-Fr(S)	[955] 8.9.15 - 3.10.15 Mo+Di	[975] 2.8.15 - 10.8.15 Di	[975] 2.8.15 - 10.8.15 Di
[843] 7.8.15 - 3.10.15 Di	[946] 2.8.15 - 9.8.15 Di-Fr	[956] 2.8.15 - 9.8.15 Di	[976] 2.8.15 - 9.8.15 Di	[976] 2.8.15 - 9.8.15 Di
[908] 11.8.15 - 6.9.15 Di+Do	[947] 10.8.15 - 7.9.15 Mo	[957] 6.9.15 - 3.10.15 Di	[977] 6.9.15 - 3.10.15 Di	[977] 6.9.15 - 3.10.15 Di

ROW	RW	RHL
[968] 10.8.15 - 3.10.15 Di	[968] 10.8.15 - 3.10.15 Di	[968] 10.8.15 - 3.10.15 Di

RBA A	RW
[968] 10.8.15 - 3.10.15 Di	[968] 10.8.15 - 3.10.15 Di

RBA A	RW
[968] 10.8.15 - 3.10.15 Di	[968] 10.8.15 - 3.10.15 Di

Basel Bad Bf Basel SBB Pb	
GWB	
P2B	
Hauptbahn	
70 <100 >	
4404	
1.6	
5.1	
	3.5

BAV 520

Basel Bad Bf Basel Bad Rbf(GR A)	
	P2B
	Hauptbahn
	60
	4415
2.9	0.3
2.8	3.1
0.8	
2.6	0.4
	2.2

BAV 508 / 1

BAV 508 / 2

Basel Bad Rbf Weil (Rh) - Haltingen	
GWB	
L2B und P2B	
Hauptbahn	
130 <160 >	
4000	180
2.0	1.1
281.7	281.0
	2.3
	284.3

BAV 521 / 1

Basel Bad Rbf Weil (Schlaufe)	
	P2B
	Hauptbahn
	60
	4411
	2.7
3.5	
	0.8

3.5

Basel Bad Rbf Weil (Sig N10)	
	P2B
	Hauptbahn
	60
	4415
	1.3
0.0	
	1.3

0.0

Basel Bad Bf
BR Einf SBB Pb

Basel Bad Bf
BR Rbf -Gr-L
Basel Rbf -Gr-L
BR Rbf -Gr-C
BR Rbf -Gr-A

Basel Bad Bf
Weil (Rhein) LGr
Weil am Rhein
Haltingen

BR Rbf -Gr-A
Weil am Rhein

BR Rbf -Gr-A
Weil am Rhein

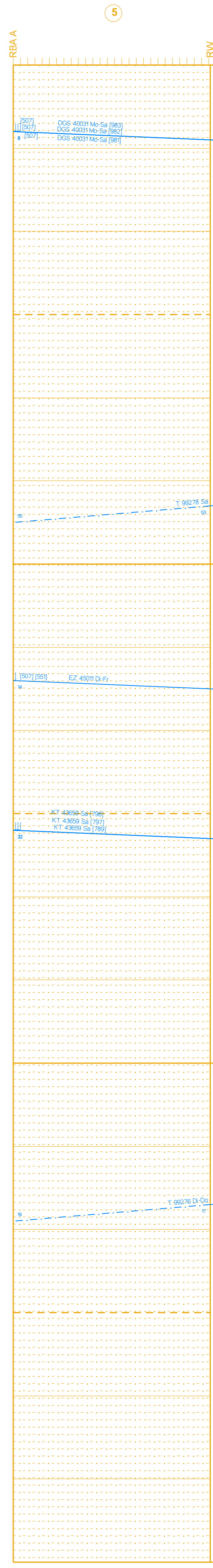
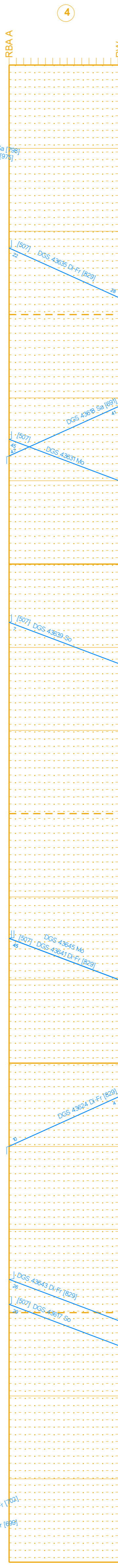
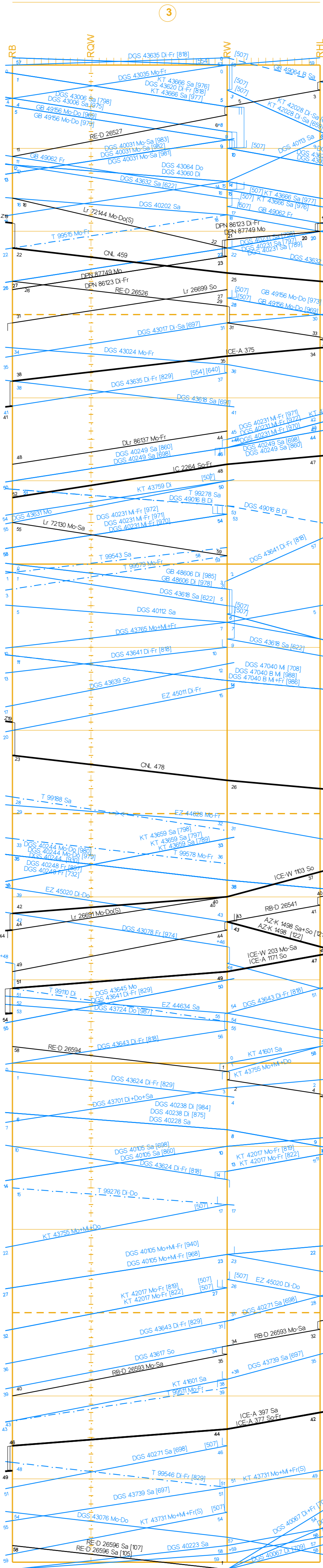
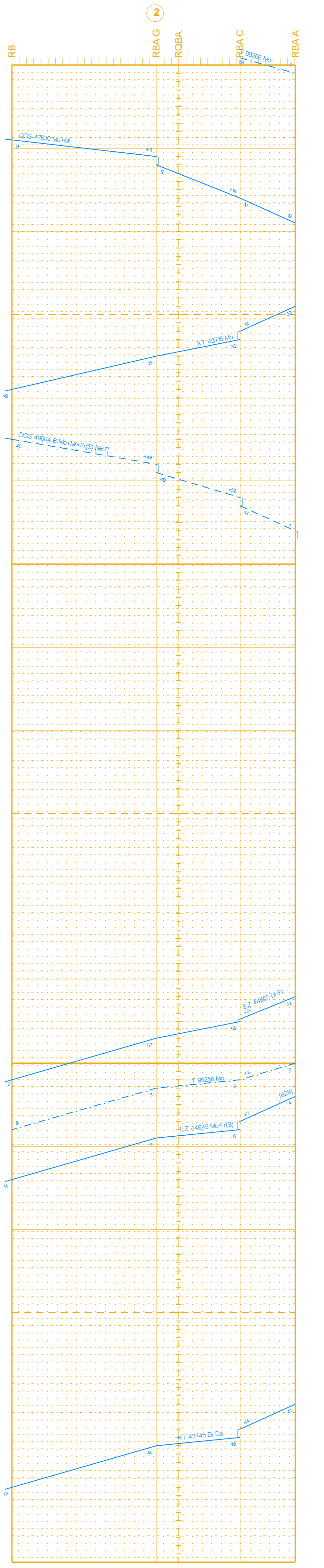
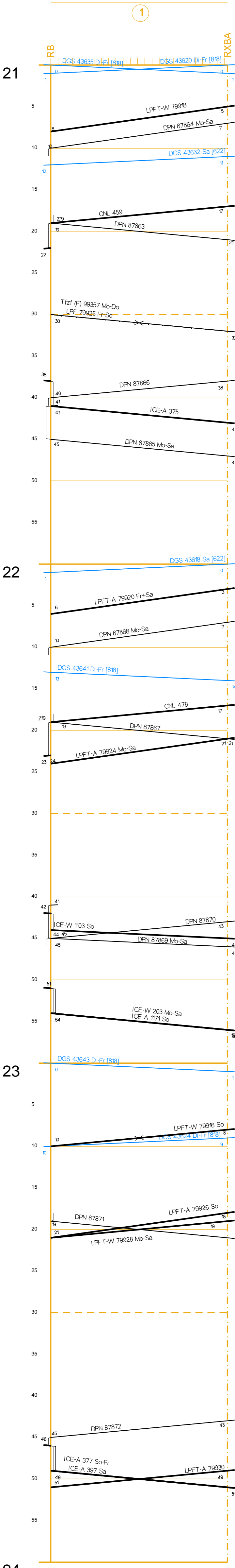

ICB	[507]	Zuspersonalwechsel	[891]
2.8.15 - 29.9.15 Sa	[507]	Zuspersonalwechsel	[891]
28.8.15 - 3.10.15 Sa	[551]	Systemwechsel, Bremswechsel	[891]
8.8.15 - 3.10.15 Sa+So	[702]	Systemwechsel	[702]
2.8.15 - 7.8.15	[822]	2.8.15 - 30.8.15 Sa	[706]
8.8.15 - 25.9.15 Mo-Fr	[829]	Gi 70	[708]
28.8.15 - 3.10.15 Mo+Do+Fr	[846]	Systemwechsel	[708]
	[859]	2.8.15 - 8.8.15 Di	[720]
	[872]	2.8.15 - 3.10.15 Di	[720]
	[891]	2.8.15 - 9.8.15 Sa	[721]
	[891]	31.8.15 - 3.10.15 Sa	[721]
	[897]	nicht: 3.10.15	[796]

ICB	[818]	2.8.15 - 30.8.15 Di-Fr	[818]
2.8.15 - 10.8.15 Sa	[818]	2.8.15 - 30.8.15 Di-Fr	[818]
2.8.15 - 6.8.15 Fr	[819]	2.8.15 - 31.8.15 Mo-Fr	[819]
10.8.15 - 7.8.15 Di+Fr	[822]	10.8.15 - 7.8.15 Di+Fr	[822]
8.8.15 - 3.10.15 Di+Fr	[829]	8.8.15 - 3.10.15 Di+Fr	[829]
2.8.15 - 10.8.15 Mi	[800]	11.8.15 - 3.10.15 Mi	[800]
2.8.15 - 8.8.15 Di	[875]	2.8.15 - 8.8.15 Di	[875]
11.8.15 - 3.10.15 Fr	[887]	2.8.15 - 10.8.15 Di	[876]
2.8.15 - 9.8.15 Sa	[900]	verkehr nur am 10.8.15	[876]
10.8.15 - 7.8.15 Sa	[940]	28.8.15 - 3.10.15 Sa	[876]
8.8.15 - 3.10.15 Sa	[947]	nicht: 3.8.15	[876]

ICB	[878]	2.8.15 - 14.8.15 Di	[878]
2.8.15 - 14.8.15 Di	[878]	2.8.15 - 14.8.15 Di	[878]
2.8.15 - 9.8.15 Mo-Do	[879]	2.8.15 - 9.8.15 Mo-Do	[879]
11.8.15 - 6.8.15 Mo-Sa	[881]	11.8.15 - 6.8.15 Mo-Sa	[881]
7.9.15 - 3.10.15 Mo-Sa	[882]	7.9.15 - 3.10.15 Mo-Sa	[882]
2.8.15 - 10.8.15 Mo-Sa	[883]	2.8.15 - 10.8.15 Mo-Sa	[883]
11.8.15 - 3.10.15 Di	[884]	11.8.15 - 3.10.15 Di	[884]
15.8.15 - 3.10.15 Di	[885]	nicht: 18.8.15, 25.8.15	[885]

ICB	[887]	7.9.15 - 3.10.15 Mi	[887]
11.8.15 - 6.8.15 Mo-Fr	[887]	7.9.15 - 3.10.15 Mi	[887]
nicht: 14.8.15, 21.8.15, 28.8.15	[888]	4.9.15	[888]
nicht: 18.8.15	[888]	7.9.15 - 3.10.15 Mi	[888]

ICB	[891]	15.8.15 - 3.10.15 Di	[891]
15.8.15 - 3.10.15 Di	[891]	15.8.15 - 3.10.15 Di	[891]
15.8.15 - 3.10.15 Di	[892]	15.8.15 - 3.10.15 Di	[892]
15.8.15 - 3.10.15 Di	[893]	15.8.15 - 3.10.15 Di	[893]