

Fahrpläne Basel Ost ab 06.09.2015

Stunden: 0 - 12

Fahrpläne Basel Ost ab 06.09.2015

Stunden: 0 - 12

Basel Bad Bf - Riehen			
	P2B		
	Hauptbahn		
	120		
	4400		
-1,8	2,6	0,9	2,2
		3,0	1,3
			4,3

Basel Bad Bf - Grenzach			
	GNT und P2B		
	Hauptbahn		
	130 >160 <		
	4000		
-1,8	2,5	2,7	2,4
			2,9

Basel Bad Bf - Riehen			
	P2B		
	Hauptbahn		
	120		
	4400		
-1,8	2,6	0,9	2,2
		3,0	1,3
			4,3

Basel Bad Bf - Grenzach			
	GNT und P2B		
	Hauptbahn		
	130 >160 <		
	4000		
-1,8	2,5	2,7	2,4
			2,9

Basel Bad Bf - Riehen			
	P2B		
	Hauptbahn		
	120		
	4400		
-1,8	2,6	0,9	2,2
		3,0	1,3
			4,3

Basel Bad Bf - Grenzach			
	GNT und P2B		
	Hauptbahn		
	130 >160 <		
	4000		
-1,8	2,5	2,7	2,4
			2,9

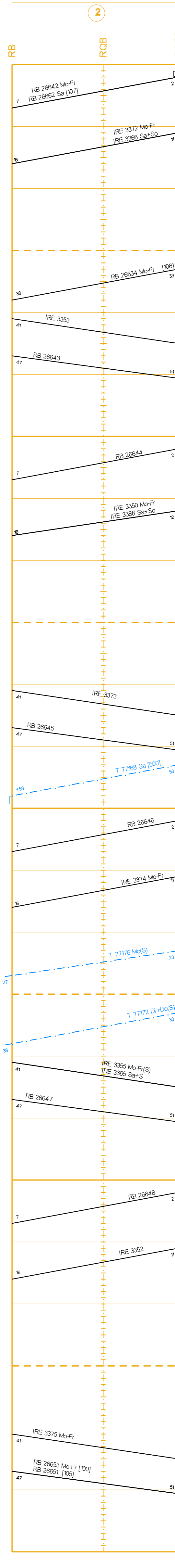
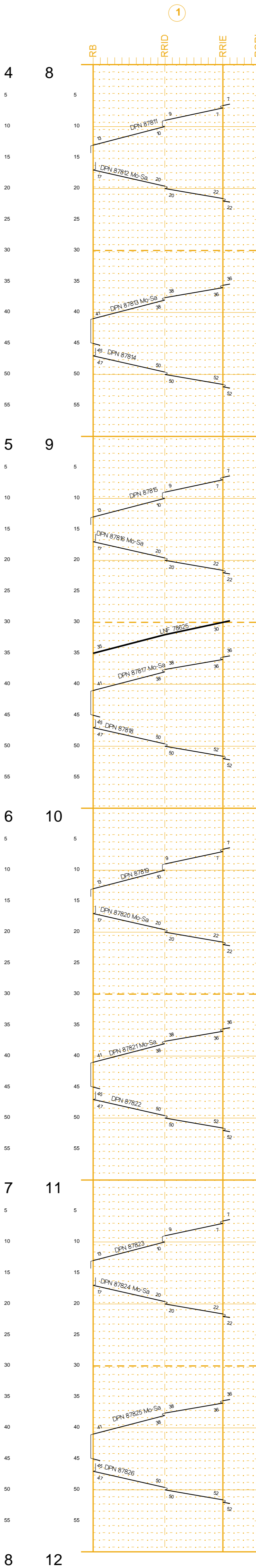
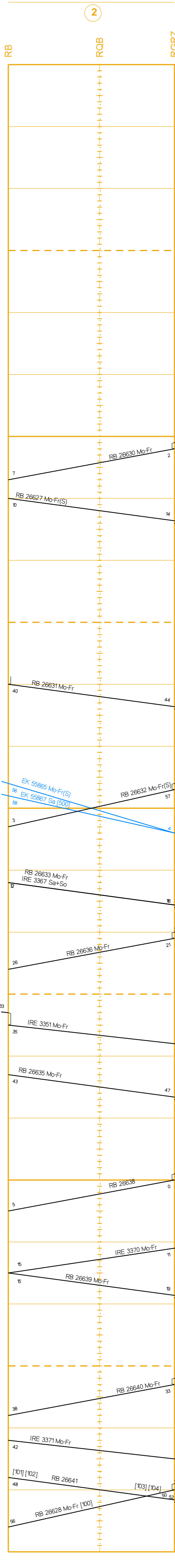
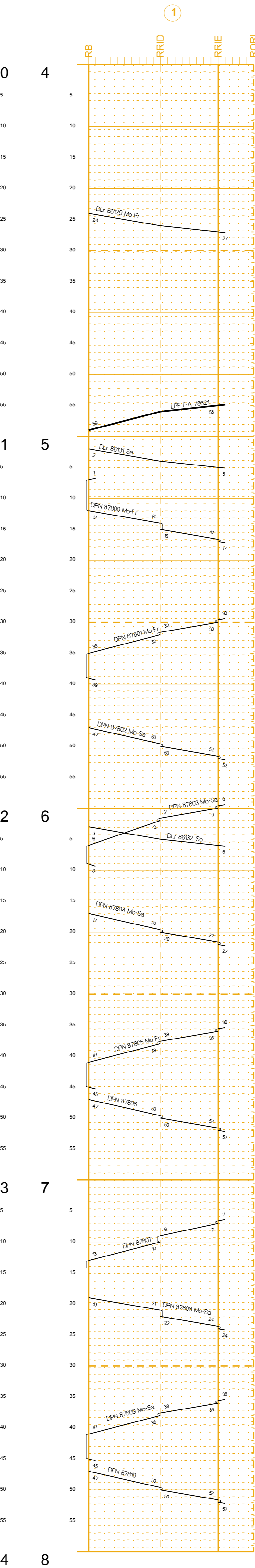
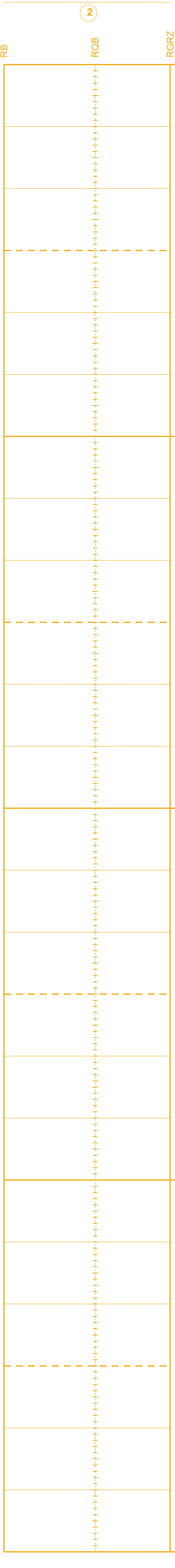
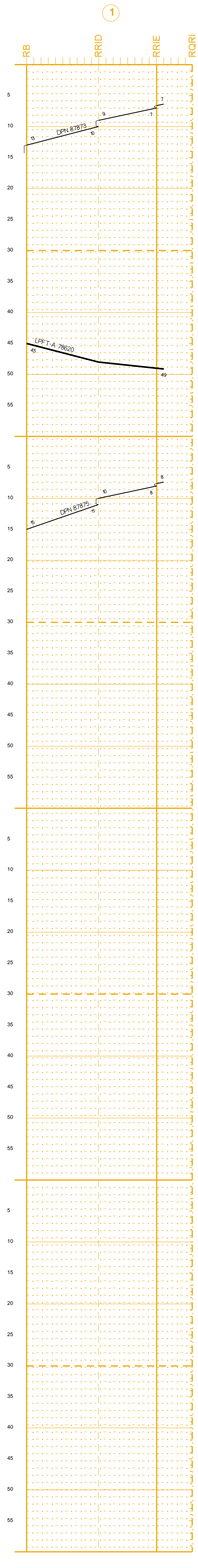

[100] 14.9.15 - 3.10.15 Mo-Fr
[101] <darf schon 7.47 Uhr abfahren>14.12.14 - 12.12.15 Mo-Fr(S)
[102] <darf schon 7.47 Uhr abfahren>14.12.14 - 12.12.15 Sa+S
[103] <darf schon 7.51 Uhr abfahren>14.12.14 - 12.12.15 Mo-Fr(S)
[104] <darf schon 7.51 Uhr abfahren>14.12.14 - 12.12.15 Mo-Fr(S)
[105] 6.9.15 - 13.9.15
19.9.15 - 3.10.15 Sa+So
[106] <darf schon um 8.32 Uhr abfahren>

[107] nicht: 3.10.15
[500] nicht: 3.10.15

[101] [102] RB 26641 [103] [104]
[105] [106] RB 26628 Mo-Fr [100]

[101] [102] RB 26641 [103] [104]
[105] [106] RB 26628 Mo-Fr [100]

[101] [102] RB 26641 [103] [104]
[105] [106] RB 26628 Mo-Fr [100]

[101] [102] RB 26641 [103] [104]
[105] [106] RB 26628 Mo-Fr [100]

[101] [102] RB 26641 [103] [104]
[105] [106] RB 26628 Mo-Fr [100]

Basel Bad Bf - Riehen	
P2B	
Hauptbahn	
120	
4400	
2.6	0.9
2.2	3.0
1.3	4.3

Basel Bad Bf - Grenzach	
GNT und P2B	
Hauptbahn	
130 >160 <	
4400	
2.5	2.4
273.2	275.6

Basel Bad Bf - Riehen	
P2B	
Hauptbahn	
120	
4400	
2.6	0.9
2.2	3.0
1.3	4.3

Basel Bad Bf - Grenzach	
GNT und P2B	
Hauptbahn	
130 >160 <	
4400	
2.5	2.4
273.2	275.6

Basel Bad Bf - Riehen	
P2B	
Hauptbahn	
120	
4400	
2.6	0.9
2.2	3.0
1.3	4.3

Basel Bad Bf - Grenzach	
GNT und P2B	
Hauptbahn	
130 >160 <	
4400	
2.5	2.4
273.2	275.6

BAV 525
 ↓ Basel Bad Bf
 Riehen Niederholz Hp
 ↓ Riehen
 Riehen LGr

BAV 521 / 2
 ↓ Basel Bad Bf
 Basel Bad Bf LGr
 ∇ △ Sbk 9093 / Sbk 9092
 ↓ Grenzach

BAV 525
 ↓ Basel Bad Bf
 Riehen Niederholz Hp
 ↓ Riehen
 Riehen LGr

BAV 521 / 2
 ↓ Basel Bad Bf
 Basel Bad Bf LGr
 ∇ △ Sbk 9093 / Sbk 9092
 ↓ Grenzach

BAV 525
 ↓ Basel Bad Bf
 Riehen Niederholz Hp
 ↓ Riehen
 Riehen LGr

BAV 521 / 2
 ↓ Basel Bad Bf
 Basel Bad Bf LGr
 ∇ △ Sbk 9093 / Sbk 9092
 ↓ Grenzach

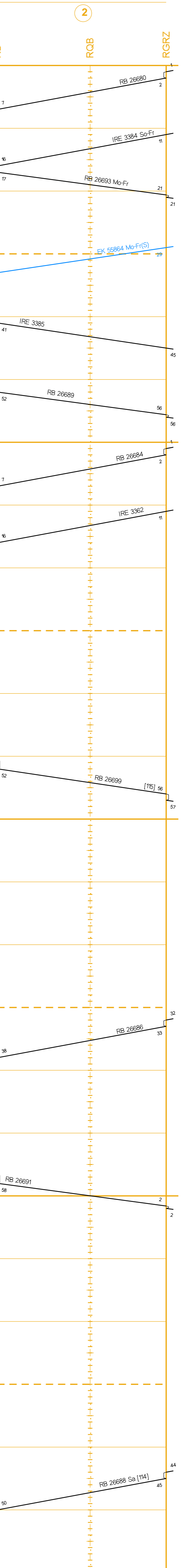
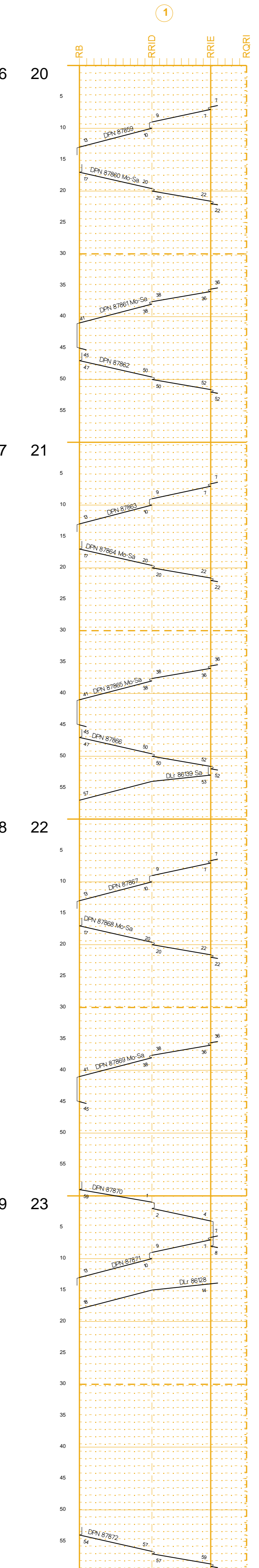
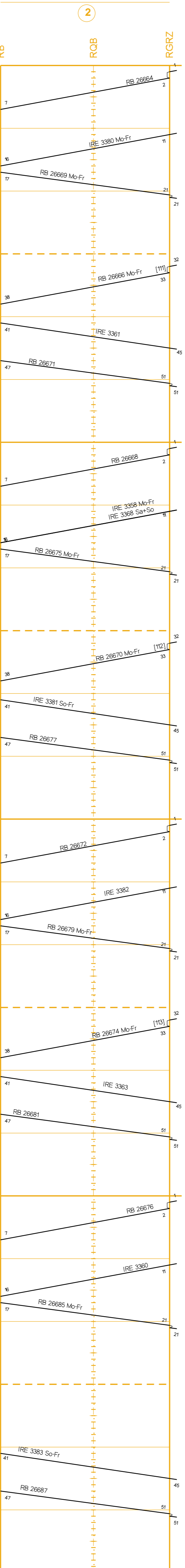
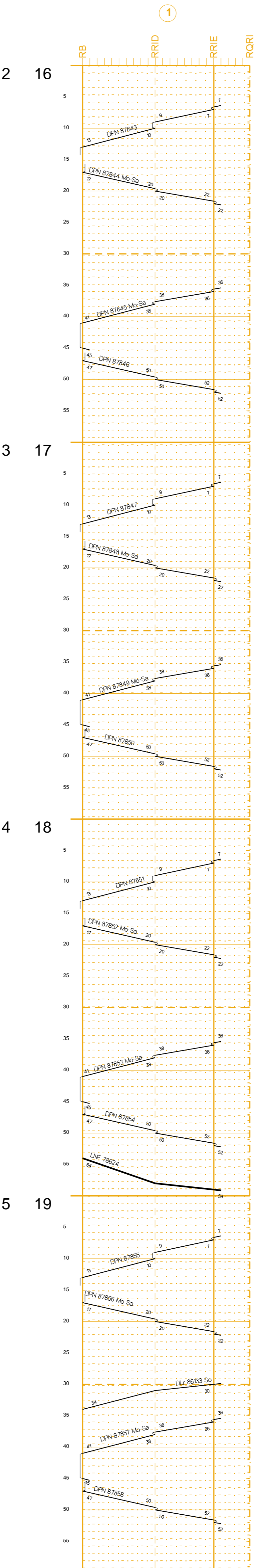
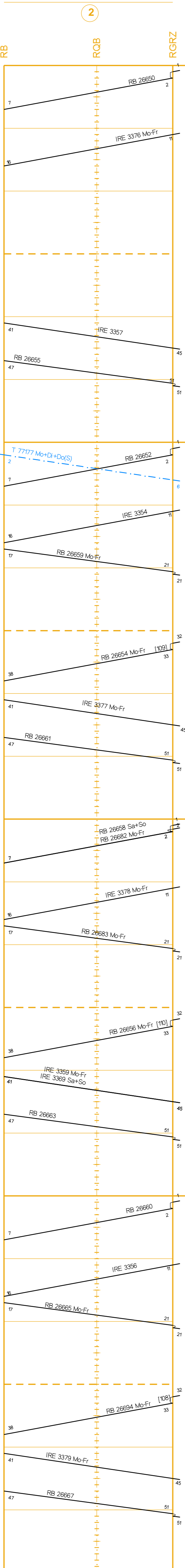
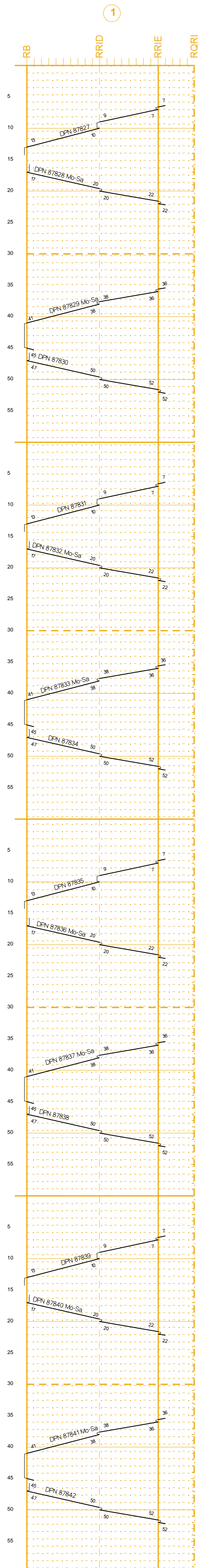

12
 13
 14
 15
 16

13
 14
 15
 16
 20

16
 17
 18
 19
 20

20
 21
 22
 23
 24

21
 22
 23
 24

22
 23
 24

[108] <darf schon um 15.32 Uhr abfahren>
 [109] <darf schon um 13.32 Uhr abfahren>
 [110] <darf schon um 14.32 Uhr abfahren>
 [111] <darf schon um 16.32 Uhr abfahren>
 [112] <darf schon um 17.32 Uhr abfahren>
 [113] <darf schon um 18.32 Uhr abfahren>
 [114] nicht: 3.10.15
 auch: 2.10.15

[115] <darf bereits um 21.56 Uhr abfahren>