

Basel Bad Bf - Riehen	
P2B	
Hauptbahn	
120	
4400	
2.6	0.8
2.2	3.0
1.3	4.3

Basel Bad Bf - Grenzach	
GNT und P2B	
Hauptbahn	
130 > 160 <	
4000	
2.5	2.4
27.2	27.6

Basel Bad Bf - Riehen	
P2B	
Hauptbahn	
120	
4400	
2.6	0.8
2.2	3.0
1.3	4.3

Basel Bad Bf - Grenzach	
GNT und P2B	
Hauptbahn	
130 > 160 <	
4000	
2.5	2.4
27.2	27.6

Basel Bad Bf - Riehen	
P2B	
Hauptbahn	
120	
4400	
2.6	0.8
2.2	3.0
1.3	4.3

Basel Bad Bf - Grenzach	
GNT und P2B	
Hauptbahn	
130 > 160 <	
4000	
2.5	2.4
27.2	27.6

BAV 525
Basel Bad Bf
Riehen Niederholz Hp
Riehen
Riehen LGR

BAV 521 / 2
Basel Bad Bf
Basel Bad Bf LGR
Sbk 9093 / Sbk 9092
Grenzach

BAV 525
Basel Bad Bf
Riehen Niederholz Hp
Riehen
Riehen LGR

BAV 521 / 2
Basel Bad Bf
Basel Bad Bf LGR
Sbk 9093 / Sbk 9092
Grenzach

BAV 525
Basel Bad Bf
Riehen Niederholz Hp
Riehen
Riehen LGR

BAV 521 / 2
Basel Bad Bf
Basel Bad Bf LGR
Sbk 9093 / Sbk 9092
Grenzach

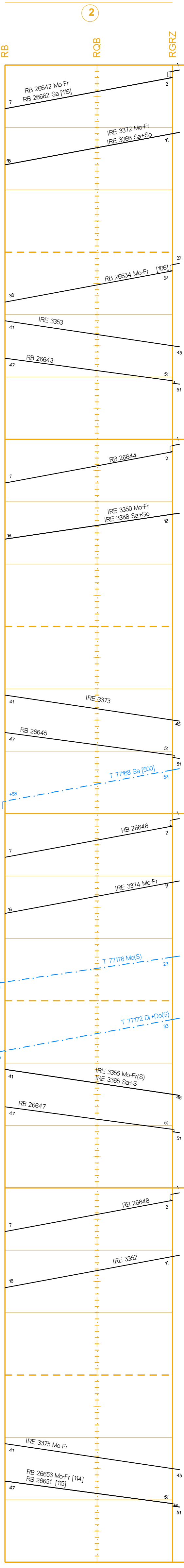
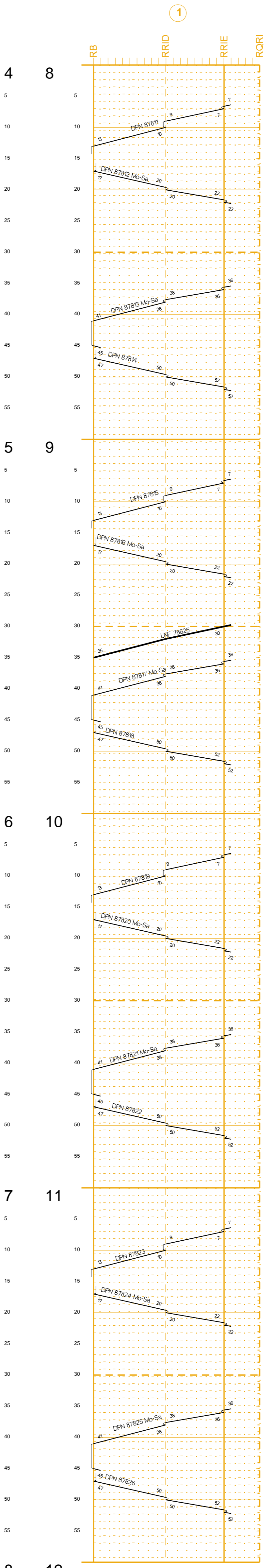
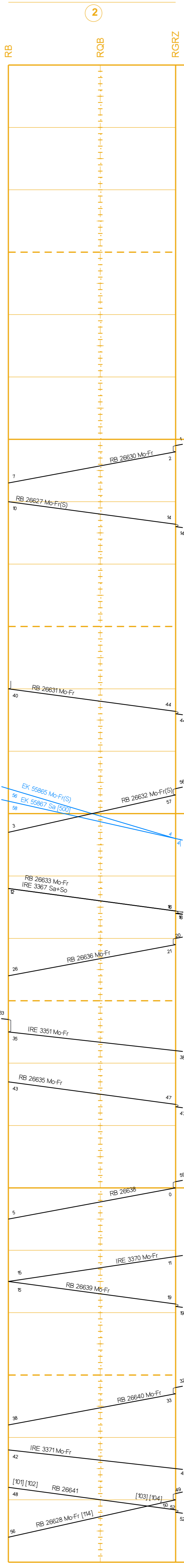
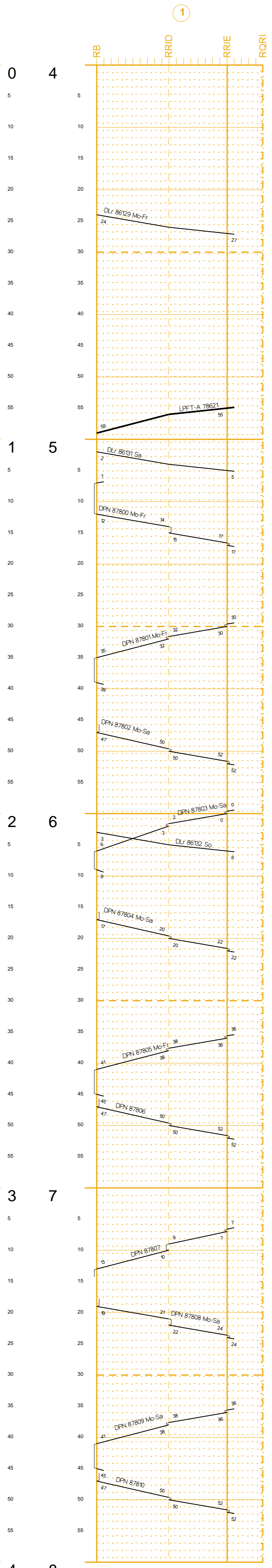
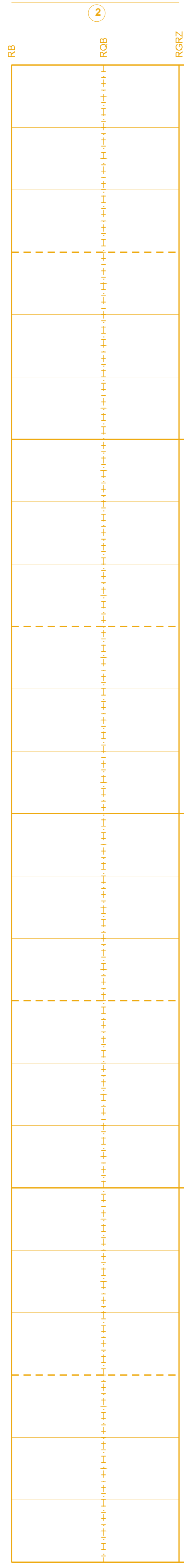
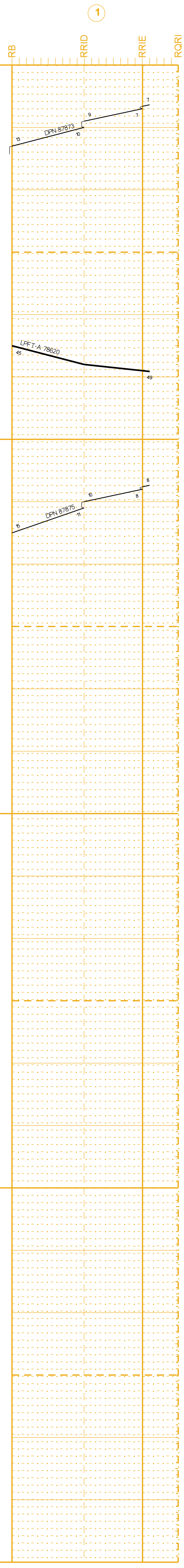

[101] <darf schon 7.47 Uhr abfahren>14.12.14 - 12.12.15 Mo-Fr(S) [116] nicht: 3.10.15
 [102] <darf schon 7.47 Uhr abfahren>14.12.14 - 12.12.15 Sa+S
 [103] <darf schon 7.51 Uhr abfahren>14.12.14 - 12.12.15 Sa+S
 [104] <darf schon 7.51 Uhr abfahren>14.12.14 - 12.12.15 Mo-Fr(S)
 [106] <darf schon um 8.32 Uhr abfahren>
 [114] 14.9.15 - 3.10.15 Mo-Fr
 [115] 2.8.15 - 13.9.15
 19.9.15 - 3.10.15 Sa+So

[500] nicht: 3.10.15

