

Altitude au dessus de la mer
RPN = 373.60

Profil en long

Pente maximum

Rampe maximum

0/00

Situation des stations, bifurcations, plus longues voies d'évitement

Stations de block

d/p Renens

Distance de stat. à stat.

Kilométrage de la voie

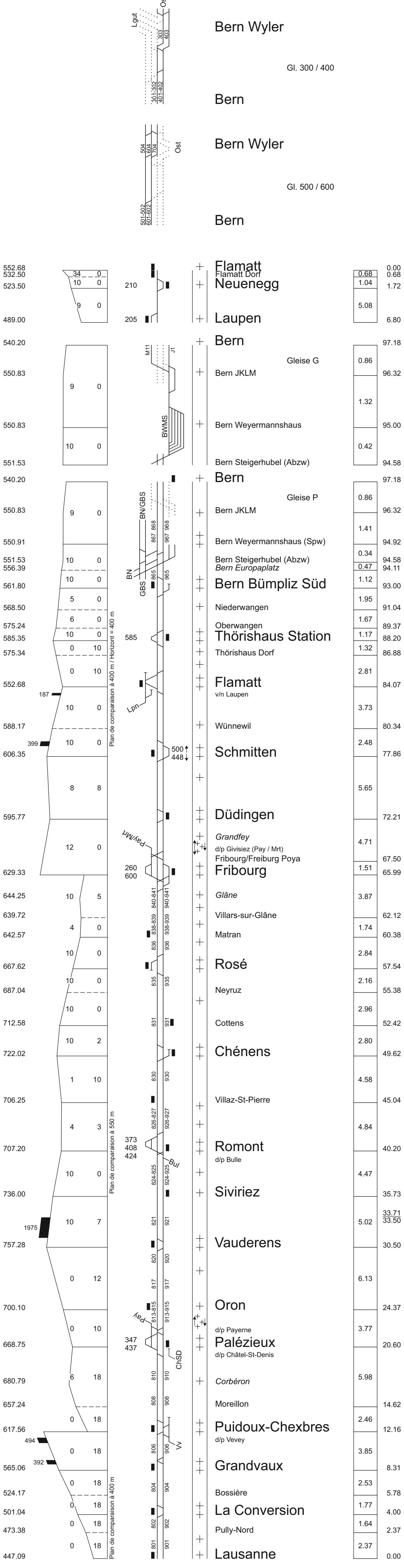

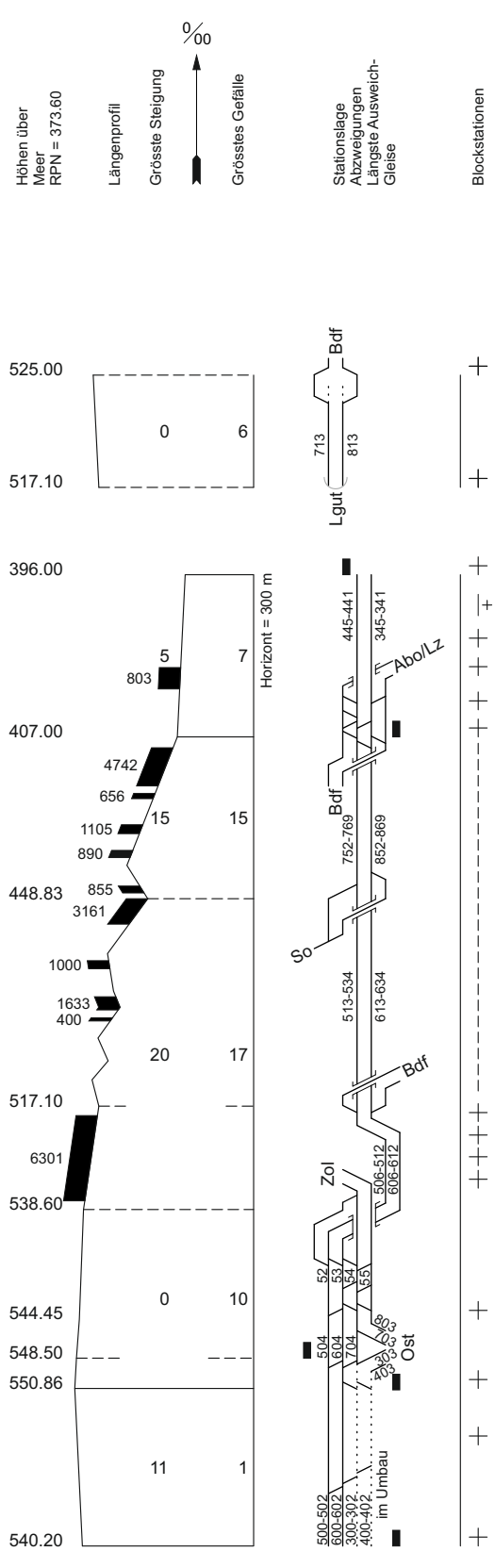
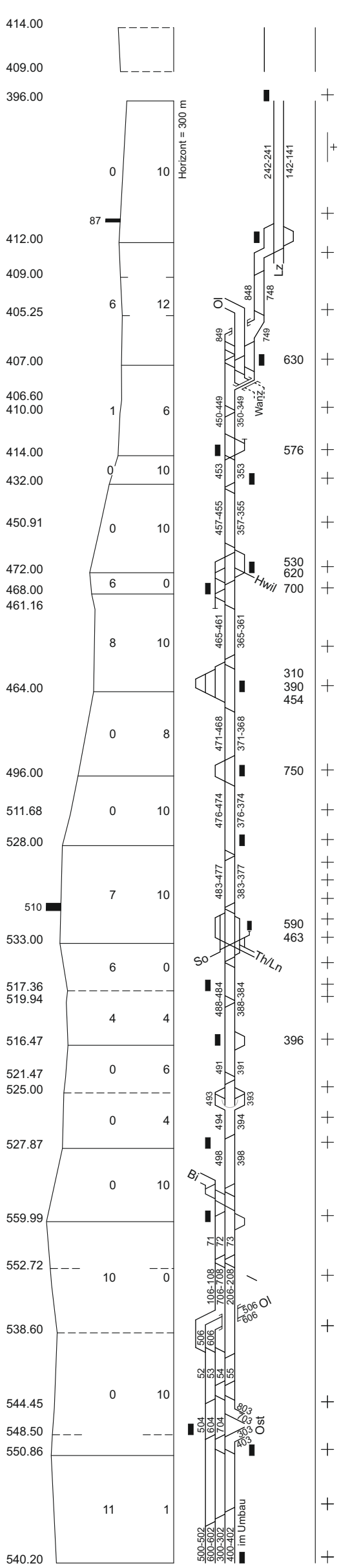

Station	Kilometer	Abzweig
Aarburg-Oftringen Süd (Abzw)	00.83	
Aarburg-Oftringen West (Abzw)	00.00	0.83
Olten	39.29	3.71
Aarburg-Oftringen	43.01	0.97
Aarburg-Oftringen West (Abzw)	43.97	0.89
Bifang AG (Spw)	44.86	1.34
Rothrist	46.20	2.87
Rothrist Hungerzelg Rank (Spw)	49.07	3.15
Murgenthal	52.22	2.27
Roggwil-Wynau	54.49	4.62
Langenthal	59.11	
Langenthal GB	59.19	1.18
Langenthal West (Abzw)	60.38	0.88
Langenthal West (Abzw)	61.26	
Herzogenbuchsee	66.42	5.46
Herzogenbuchsee	66.50	
Herzogenbuchsee	66.79	
Riedtwil	72.33	5.54
Lochmatt	76.93	4.60
Wynigen	76.93	
v/n Solothurn	83.39	6.46
Burgdorf	83.39	
v/n Hasle-Rüegsau	87.20	3.15
Lyssach Sandacher (Spw)	86.54	0.66
Lyssach Sandacher (Spw)	87.20	
Hindelbank	89.73	2.53
Hardfeld (Spw)	91.66	1.93
Mattstetten (Abzw)	91.98	0.32
Schönbühl SBB	94.91	2.93
v/n Biel/Bienne	98.81	3.89
Zollikofen	98.81	
Zollikofen West (Spw)	99.86	1.05
Zollikofen West (Spw)	99.88	
Löchligut	101.28	1.40
Löchligut	101.28	1.22
Löchligut Süd (Abzw)	102.50	
Bern Wankdorf	102.94	0.44
Bern Wyler	103.33	0.39
Bern Wyler	103.33	
Bern	106.13	2.80

Station	Kilometer	Abzweig
Bern JKLM		
Bern		
Bern JKLM		
Bern JKLM		
Bern Weyermannshaus		
Mattstetten (Abzw)	92.09	0.68
Mattstetten (Abzw)	92.09	
Aespli	92.77	12.28
Aespli	92.77	
Olten Nord-Ost (Abzw)	39.29	5.86
Olten	39.29	
Rothrist	45.15	
v/n Burgdorf	46.20	
Rothrist	47.35	
Rothrist	55.29	
Rothrist	19.39	
Wanzwil (Abzw)	36.98	
v/n Solothurn	24.71	
v/n Burgdorf	12.28	
Aespli	12.28	
Löchligut	7.43	
Löchligut	4.85	101.28
Löchligut	101.28	1.22
Löchligut Süd (Abzw)	102.50	
Bern Wankdorf	102.94	0.44
Bern Wyler	103.33	0.39
Bern Wyler	103.33	
Bern	106.13	2.80

Gleise P (J2,J7,J8)
Gleise G (J1,M11)
Einf. von Stat. zu Stat.
Kilometrierung der Bahn



I-FN-FPA-RME

Ausgabe von 11.12.2016

352.2
351.9
355.0
353.8
373.7
383.3
383.3
374.0

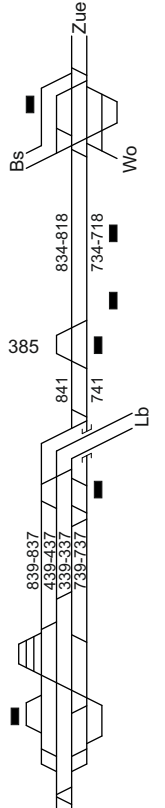
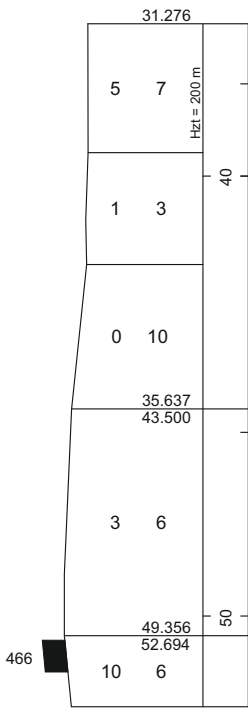

v. u. n. Zürich

BRUGG (AG)

Schinznach Bad

Holderbank AG

Wildeg

Rupperswil

Rohr (Spw)

AARAU

GB
PB

Wöschnau (Spw)

12.23
4.87
7.36
2.61
4.75
1.66
3.09
3.09
0.00
19.25
4.65
14.60
1.20
13.40
1.53
11.87

Meter
Höhen über Meer
RPN = 373.60

Längenprofil
Grösste Steigung ‰
Grösstes Gefälle
Kilometrierung

Stationslage
Abzweigungen
Längste Ausweichgleise

Blockstationen bzw. Blockstellen

Entf. von Stat. zu Stat.

Entf. vom Ausgangspunkt

394.0
393.1
401.5
397.0
396.5
416.1
419.2
424.6
406.4
373.7
383.3
383.3
374.0
378.8
381.6
394.1
397.0
396.4

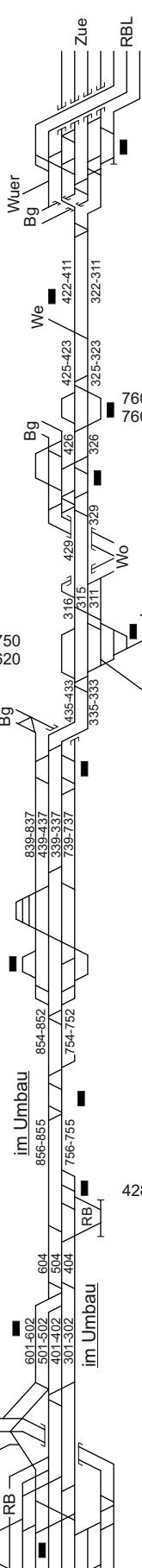
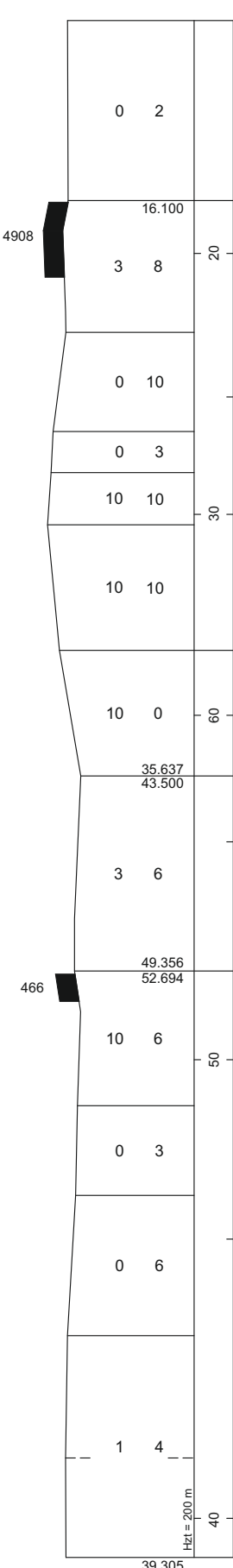

RB Limmattal

Gr. A
Gr. U
Gr. E

Killwangen-Spreitenbach

Langacher (Spw)

Mellingen Heitersberg
v. u. n. Wettingen
Grüemet (Abzw)

Mägenwil

Othmarsingen

Gexi

Lenzburg

v. u. n. Suhr

Rupperswil

Rohr (Spw)

AARAU

GB
PB

Wöschnau (Spw)

Schönenwerd Ost (Spw.)
Schönenwerd

Däniken

Dulliken

Olten Ost (Abzw)

Verbindungsline
v. u. n. Basel
OLTEN PB

v. u. n. Bern

Gleise
353
354
355

Gleise
601
501
301

3.88
1.30
38.70
37.40
5.61
31.79
2.90
28.89
1.77
27.12
2.29
24.83
1.98
22.85
3.60
19.25
4.65
14.60
1.20
13.40
1.53
11.87
3.03
8.84
2.46
6.38
2.75
3.63
3.63

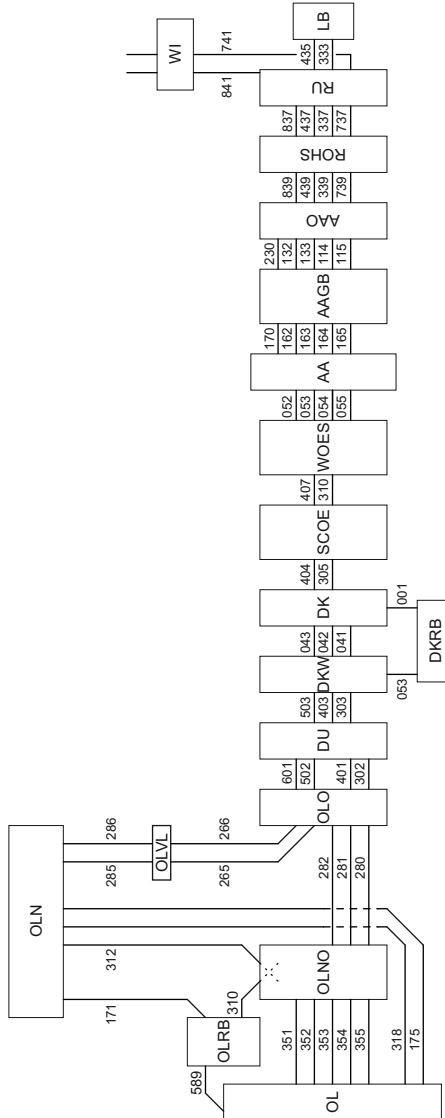



SBB 16 A

I-FN-FPA-ROT

Ausgabe von 11.12.2016

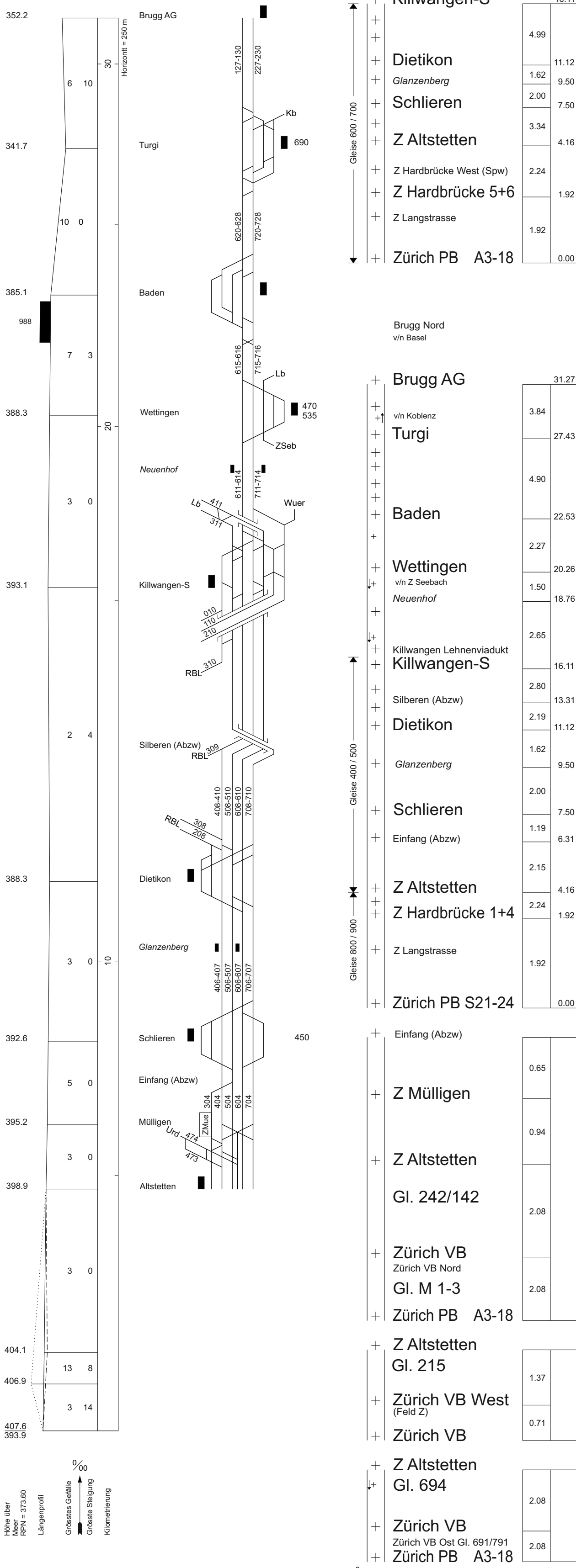

Höhe über Meer RPN = 373.60
 Längenprofil
 Grösstes Gefälle
 Grösste Steigung
 Kilometrierung

+	Killwangen-S	16.11
+		4.99
+	Dietikon	11.12
+	Glanzenberg	1.62
+	Schlieren	2.00
+		3.34
+	Z Altstetten	4.16
+	Z Hardbrücke West (Spw)	2.24
+	Z Hardbrücke 5+6	1.92
+	Z Langstrasse	1.92
+	Zürich PB A3-18	0.00

+	Brugg Nord v/n Basel	
+	Brugg AG	31.27
+	v/n Koblenz	3.84
+	Turgi	27.43
+		4.90
+	Baden	22.53
+		2.27
+	Wettingen	20.26
+	v/n Z Seebach	1.50
+	Neuenhof	18.76
+		2.65
+	Killwangen Lehnviadukt	
+	Killwangen-S	16.11
+		2.80
+	Silbernen (Abzw)	13.31
+	Dietikon	2.19
+	Glanzenberg	1.62
+		2.00
+	Schlieren	7.50
+	Einfang (Abzw)	1.19
+		2.15
+	Z Altstetten	4.16
+	Z Hardbrücke 1+4	2.24
+		1.92
+	Z Langstrasse	1.92
+	Zürich PB S21-24	0.00

+	Einfang (Abzw)	0.65
+	Z Mülligen	0.94
+	Z Altstetten	
+	Gl. 242/142	2.08
+	Zürich VB	
+	Zürich VB Nord	
+	Gl. M 1-3	2.08
+	Zürich PB A3-18	

+	Z Altstetten	
+	Gl. 215	1.37
+	Zürich VB West (Feld Z)	0.71
+	Zürich VB	
+	Z Altstetten	
+	Gl. 694	2.08
+	Zürich VB	
+	Zürich VB Ost Gl. 691/791	2.08
+	Zürich PB A3-18	

+	Urdorf	
+	v/n Zug	4.41
+	Z Altstetten	2.35
+	Hard Käferberg (Abzw)	
+		3.08
+	Z Oerlikon	



I-FN-FPA-ROT

Ausgabe von 11.12.2016

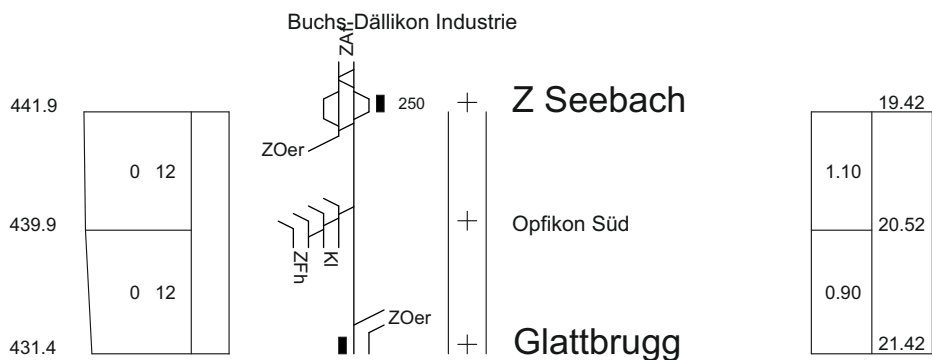
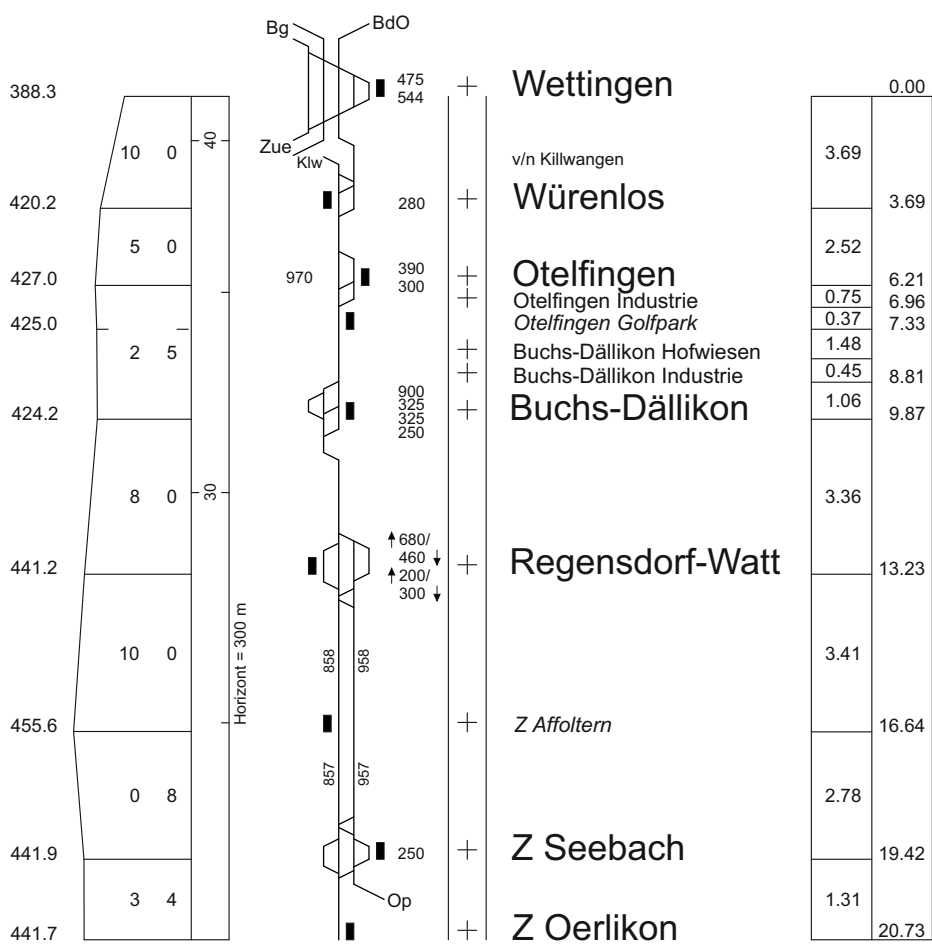
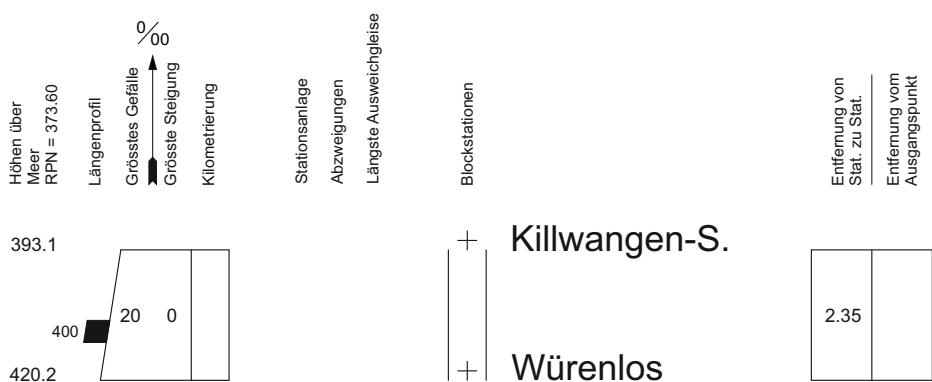



SBB

I-FN-FPA-ROT

RBL 18

Ausgabe von 11.12.2016

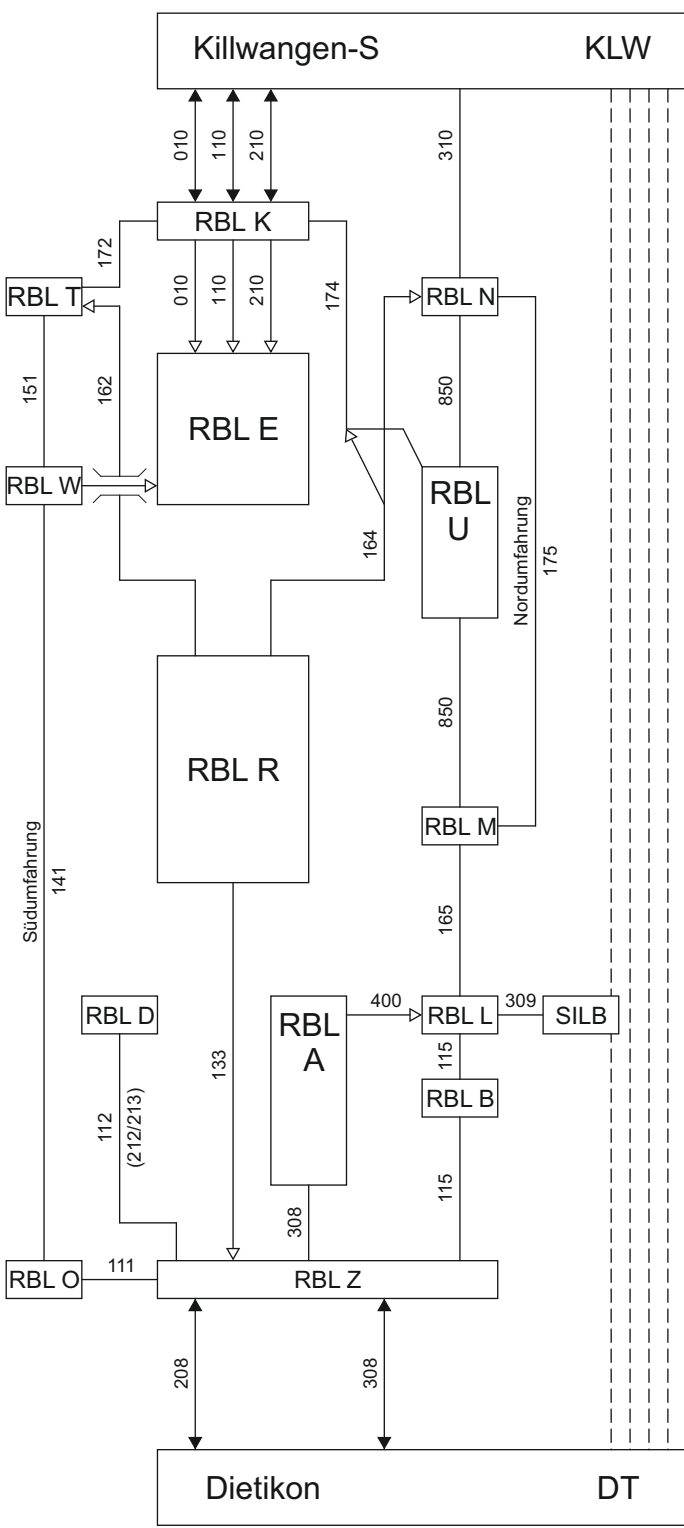

- \longleftrightarrow Wechselbetrieb
- $\longleftarrow \longrightarrow$ Obligatorische Fahrrichtung

© Infrastruktur - Fahrplan und Netzdesign, Bern

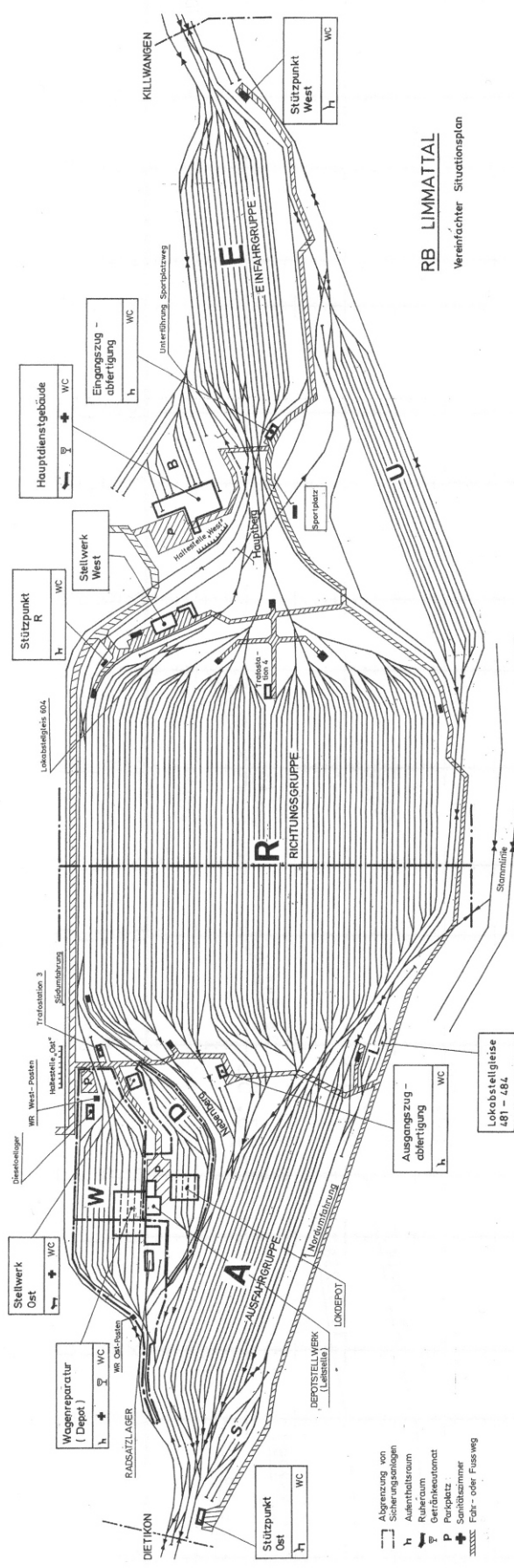

- \cdots Abgrenzung von Anlagen
- h Außenhaltungsraum
- h Ruheplatz
- P Getränkeautomat
- P Parkplatz
- $+$ Sanitätszimmer
- \times Fahr- oder Fußweg

RB LIMMATTAL
Vereinfachter Situationsplan

Lokabstellgleise 481 - 484



Stützpunkt
Ost
h WC

Dietikon

WR Ost Posten

Wagenreparatur

Depot

Neuherrng

Wagenrep. West

RB Limmatal Ost

Richtungsgruppe

V-Gruppe

Umspanngruppe

Hauptberg

Einfahrgruppe

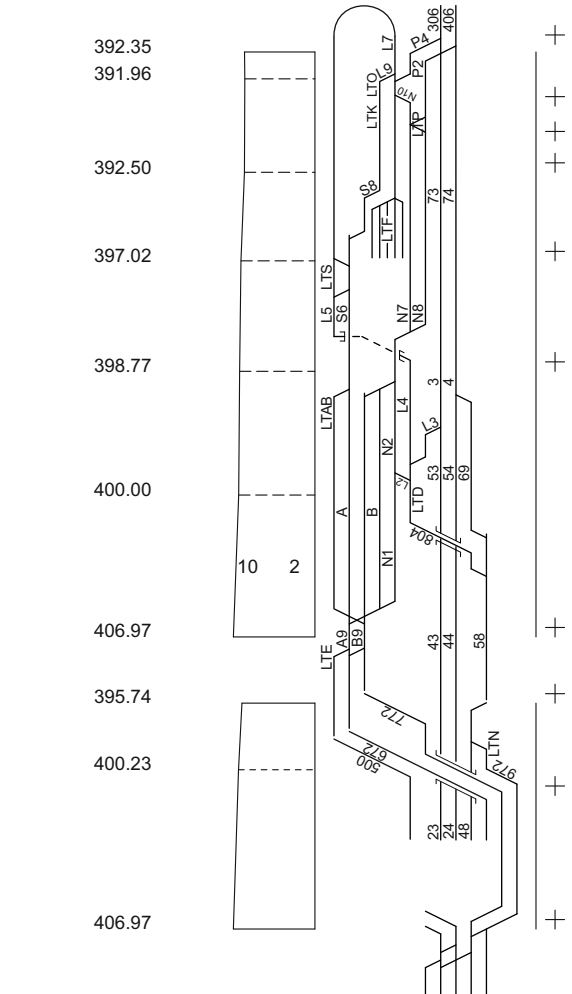
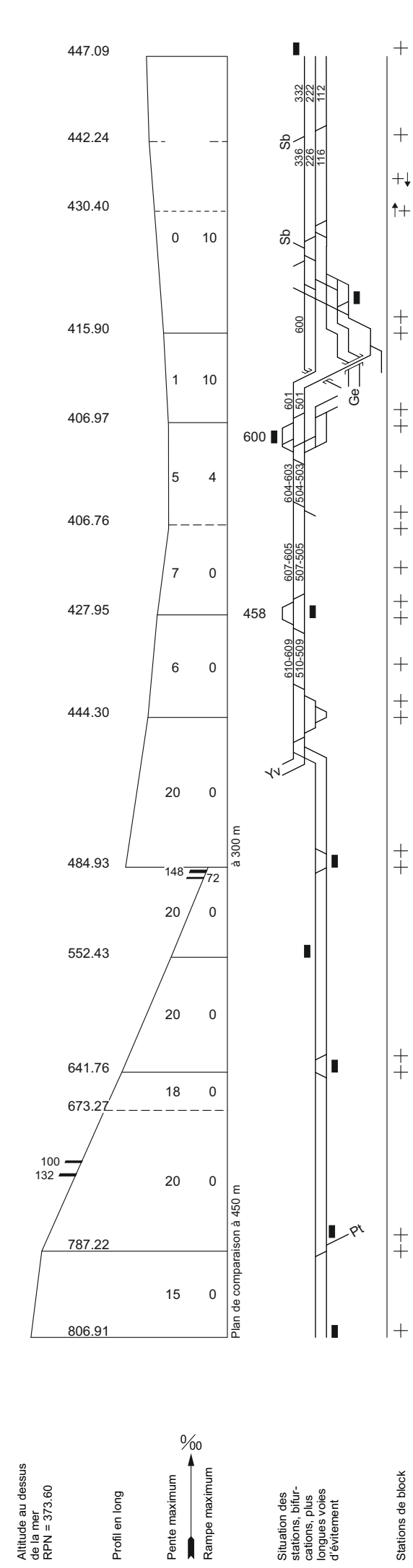
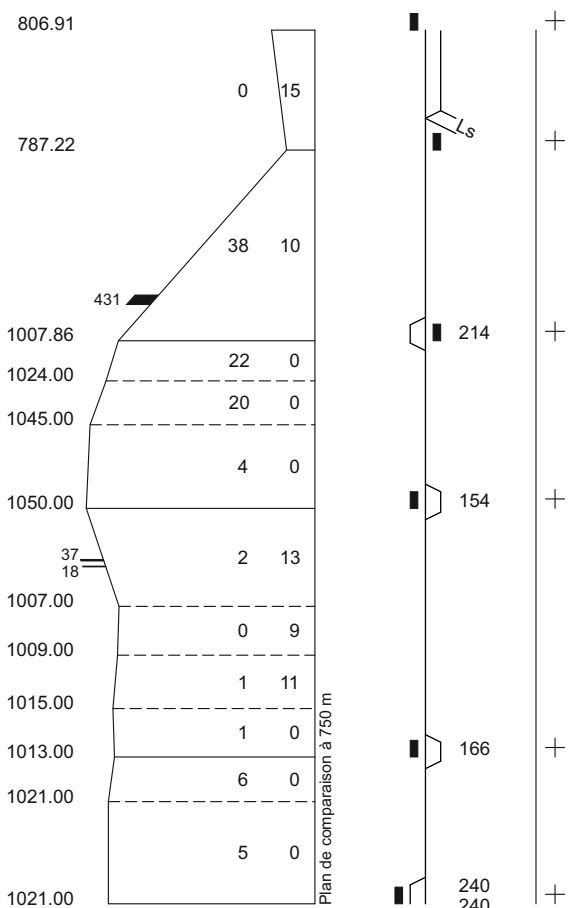

Station	Distance de stat. à stat.	Kilométrage de la voie
Vallorbe	46.31	0.00
Le Day	43.28	3.03
Le Pont	11.63	11.28
Le Lieu	2.45	15.45
Sentier-Orient	1.15	21.65
Le Brassus	1.68	24.40

Station	Distance de stat. à stat.	Kilométrage de la voie
Lausanne	1.13	0.00
Prilly-Malley	1.22	2.35
Renens VD	0.76	4.51
Bussigny	1.43	6.93
Cossonay	3.51	14.49
Dailens	4.34	18.41
La Sarraz	4.82	22.75
Vallorbe	46.31	461.60

Station	Distance de stat. à stat.	Kilométrage de la voie
Bussigny	14.92	14.92
Lausanne-Triage Nord	13.84	13.84
Lausanne-Triage D	12.85	12.85
Lausanne-Triage Sud	11.48	11.48
Lausanne-Triage F	9.30	9.30

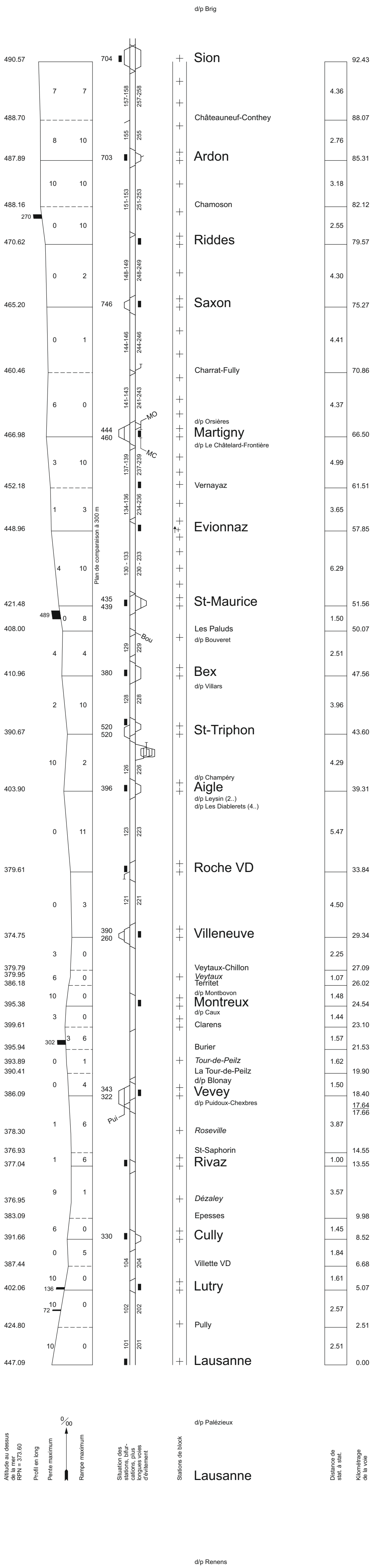

d/p Brig

d/p Palézieux

d/p Renens

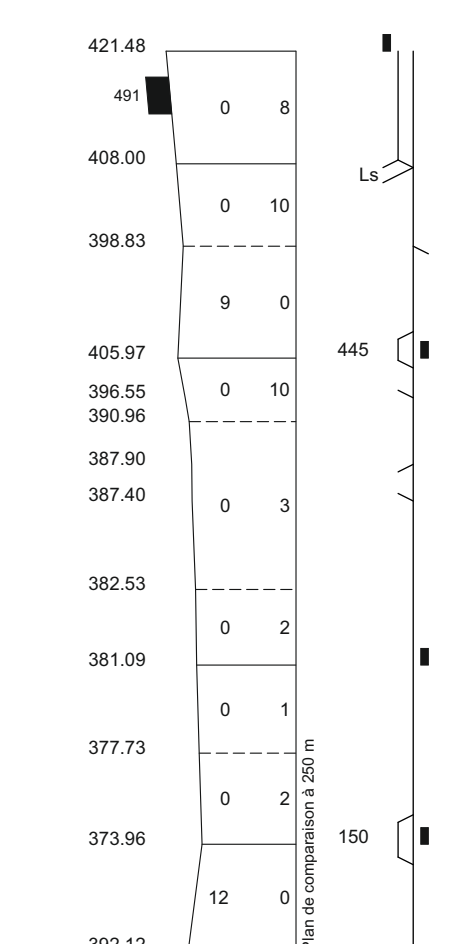

Station	Distance de stat. à stat.	Kilométrage de la voie
d/p Sion		
St-Maurice	51.56	
1.50		
Les Paluds		
d/p Lausanne	50.07	1.47
1.73		
Massongex		
2.85		
Monthey	6.05	
1.16		
Monthey Giovanola (embr)	7.21	
Collombey	0.70	7.91
1.18		
Monthey centre agr Bas-Valais (embr)	9.09	
Monthey AGIP (embr)	1.00	10.09
3.30		
Vionnaz		
2.87		
Vouvry	16.25	
3.27		
Les Evouettes		
19.53		
3.39		
Bouveret	22.91	
3.89		
26.80		
St-Gingolph (Suisse)		

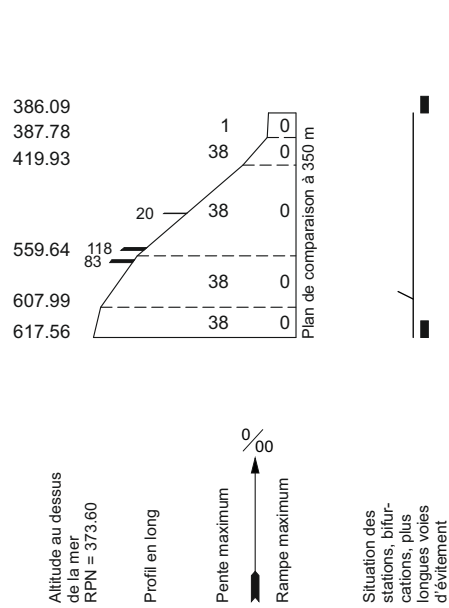

Station	Distance de stat. à stat.	Kilométrage de la voie
d/p Lausanne		
d/p Sion		
Vevey	0.00	
0.85		0.85
Vevey-Funi		
0.90		1.75
Corseaux-Cornalles		
3.86		
Chexbres-Village		
5.61		
1.49		
Le Verney (embr)	7.10	
Puidoux-Chexbres	7.83	
0.73		
d/p Lausanne		
d/p Palézieux		

Altitude au dessus de la mer
RPN = 373.60

Profil en long

Pente maximum

Rampe maximum

Situation des stations, bifurcations, plus longues voies d'évitement

Stations de block

Distance de stat. à stat.

Kilométrage de la voie

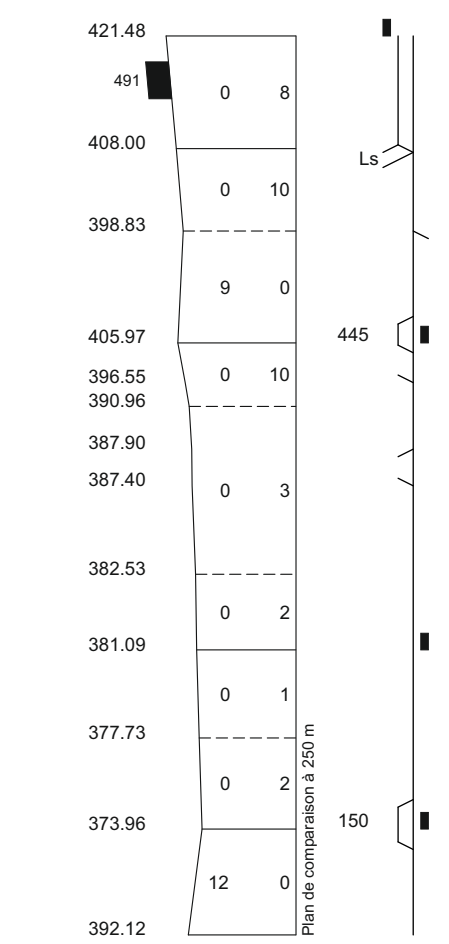

Station	Distance de stat. à stat.	Kilométrage de la voie
d/p Sion		
St-Maurice	51.56	
1.50		
Les Paluds		
d/p Lausanne	50.07	1.47
1.73		
Massongex		
2.85		
Monthey	6.05	
1.16		
Monthey Giovanola (embr)	7.21	
Collombey	0.70	7.91
1.18		
Monthey centre agr Bas-Valais (embr)	9.09	
Monthey AGIP (embr)	1.00	10.09
3.30		
Vionnaz		
2.87		
Vouvry	16.25	
3.27		
Les Evouettes		
19.53		
3.39		
Bouveret	22.91	
3.89		
26.80		
St-Gingolph (Suisse)		

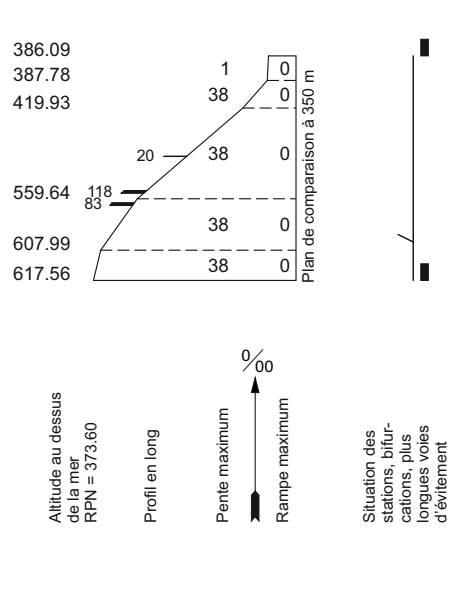

Station	Distance de stat. à stat.	Kilométrage de la voie
d/p Lausanne		
d/p Sion		
Vevey	0.00	
0.85		0.85
Vevey-Funi		
0.90		1.75
Corseaux-Cornalles		
3.86		
Chexbres-Village		
5.61		
1.49		
Le Verney (embr)	7.10	
Puidoux-Chexbres	7.83	
0.73		
d/p Lausanne		
d/p Palézieux		

Altitude au dessus de la mer
RPN = 373.60

Profil en long

Pente maximum

Rampe maximum

Situation des stations, bifurcations, plus longues voies d'évitement

Stations de block

Distance de stat. à stat.

Kilométrage de la voie

Puidoux-Chexbres

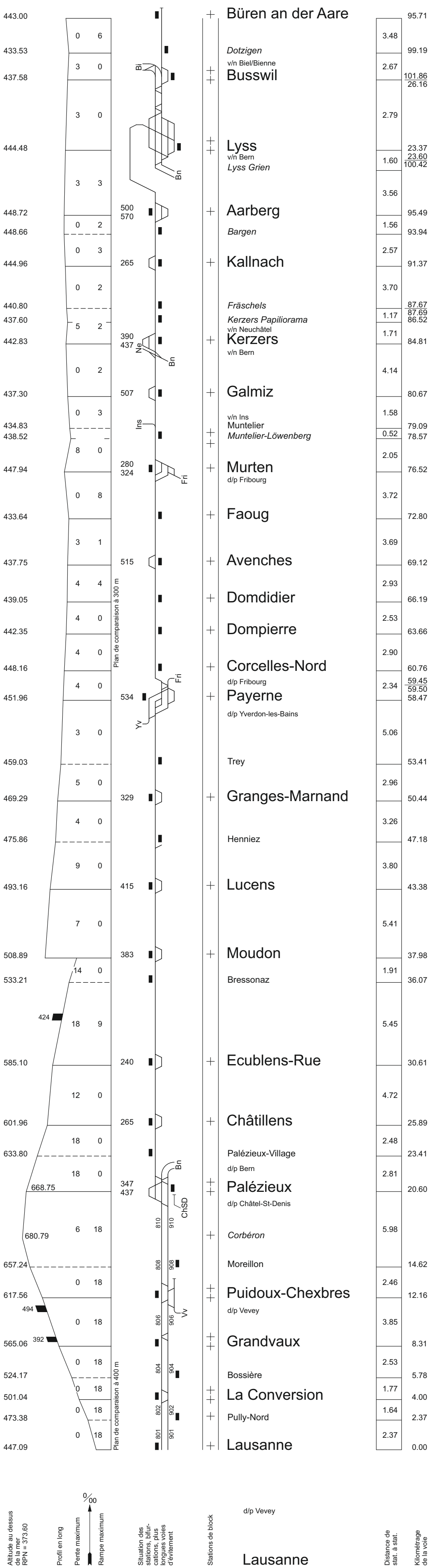

Altitude au dessus de la mer = RPN = 373.60

Profil en long
Pente maximum
Rampe maximum

Situation des stations, bifurcations, plus longues voies d'évitement

Stations de block

d/p Vevey

Lausanne

d/p Renens

Distance de stat. à stat.

Kilométrage de la voie

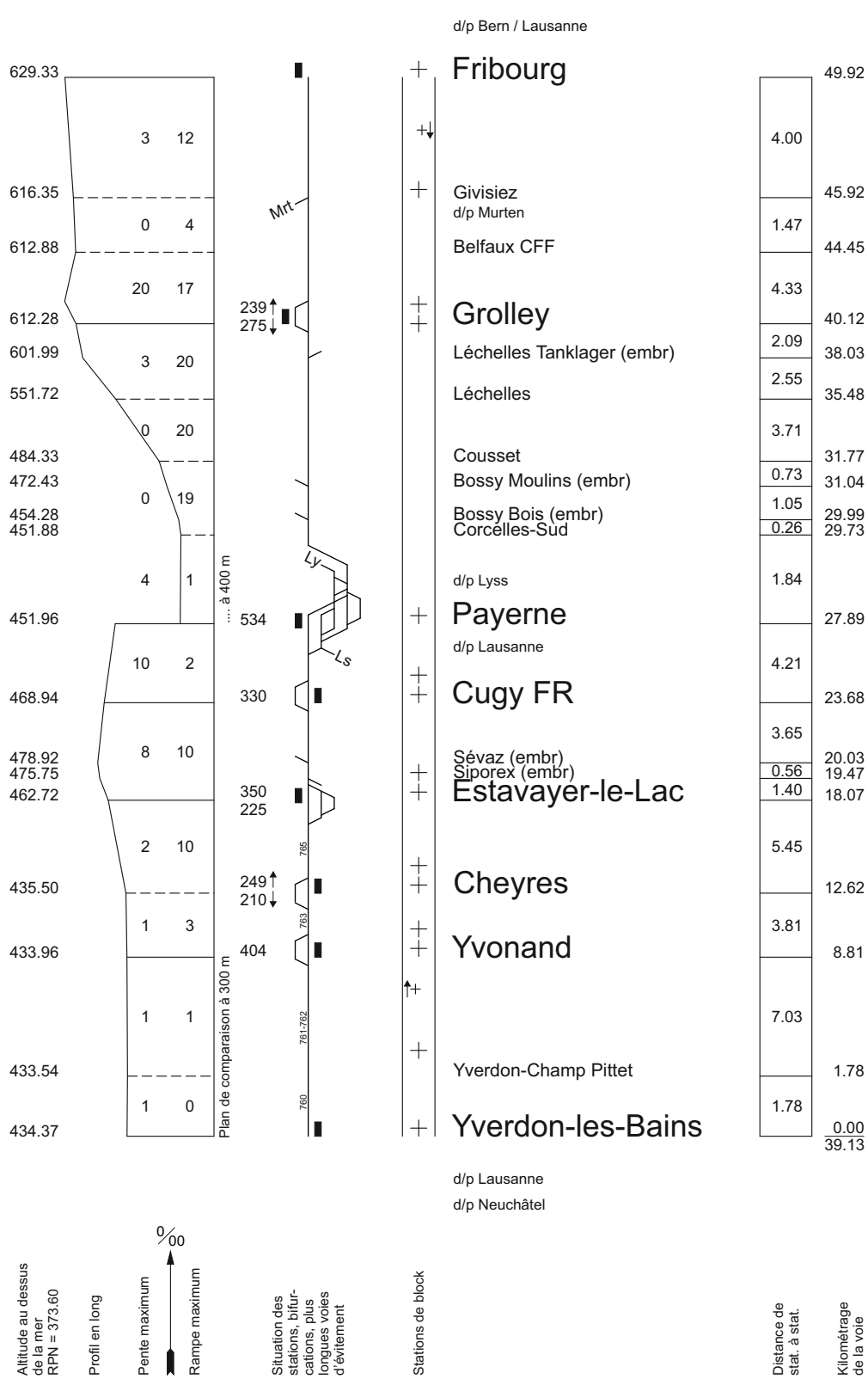

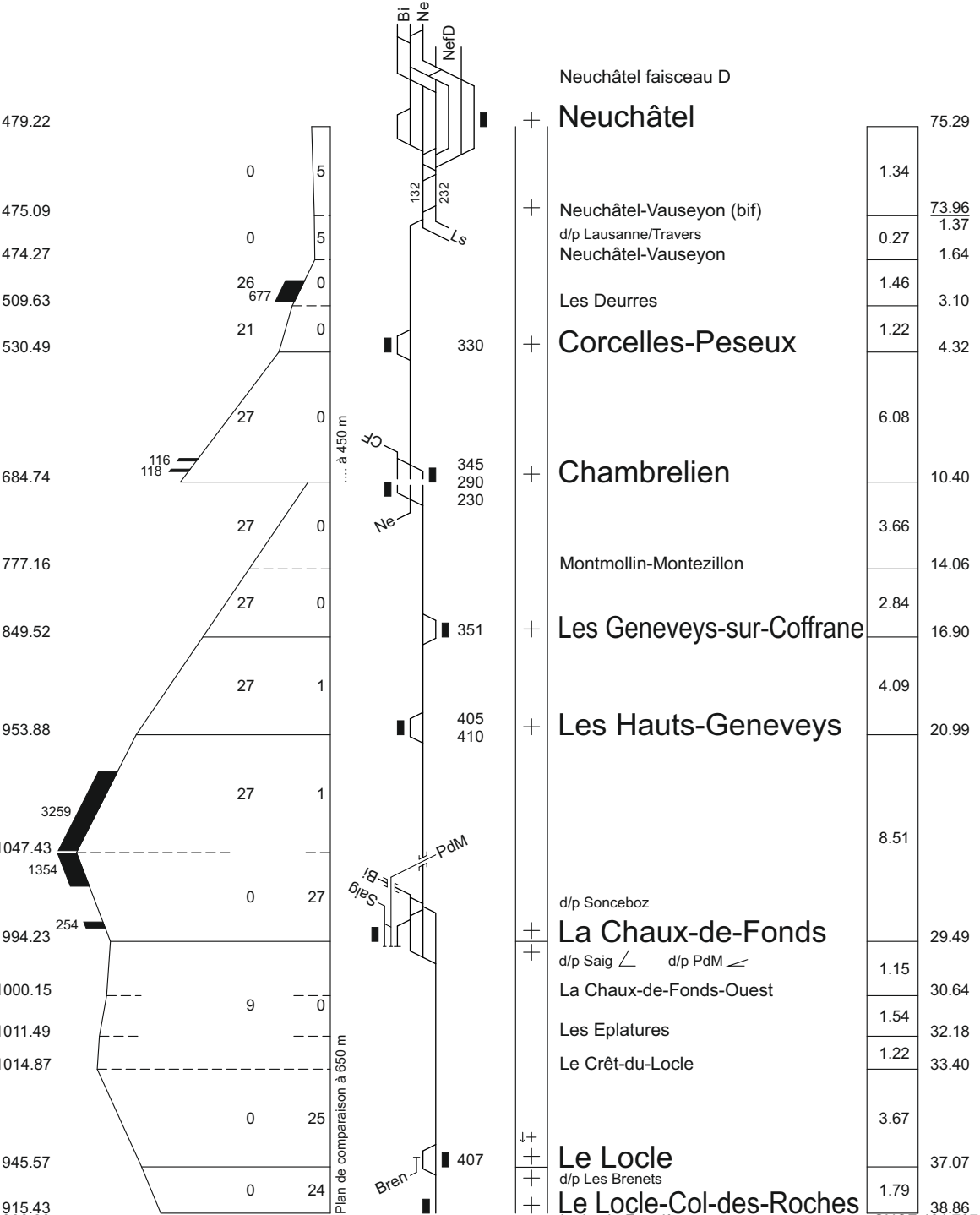
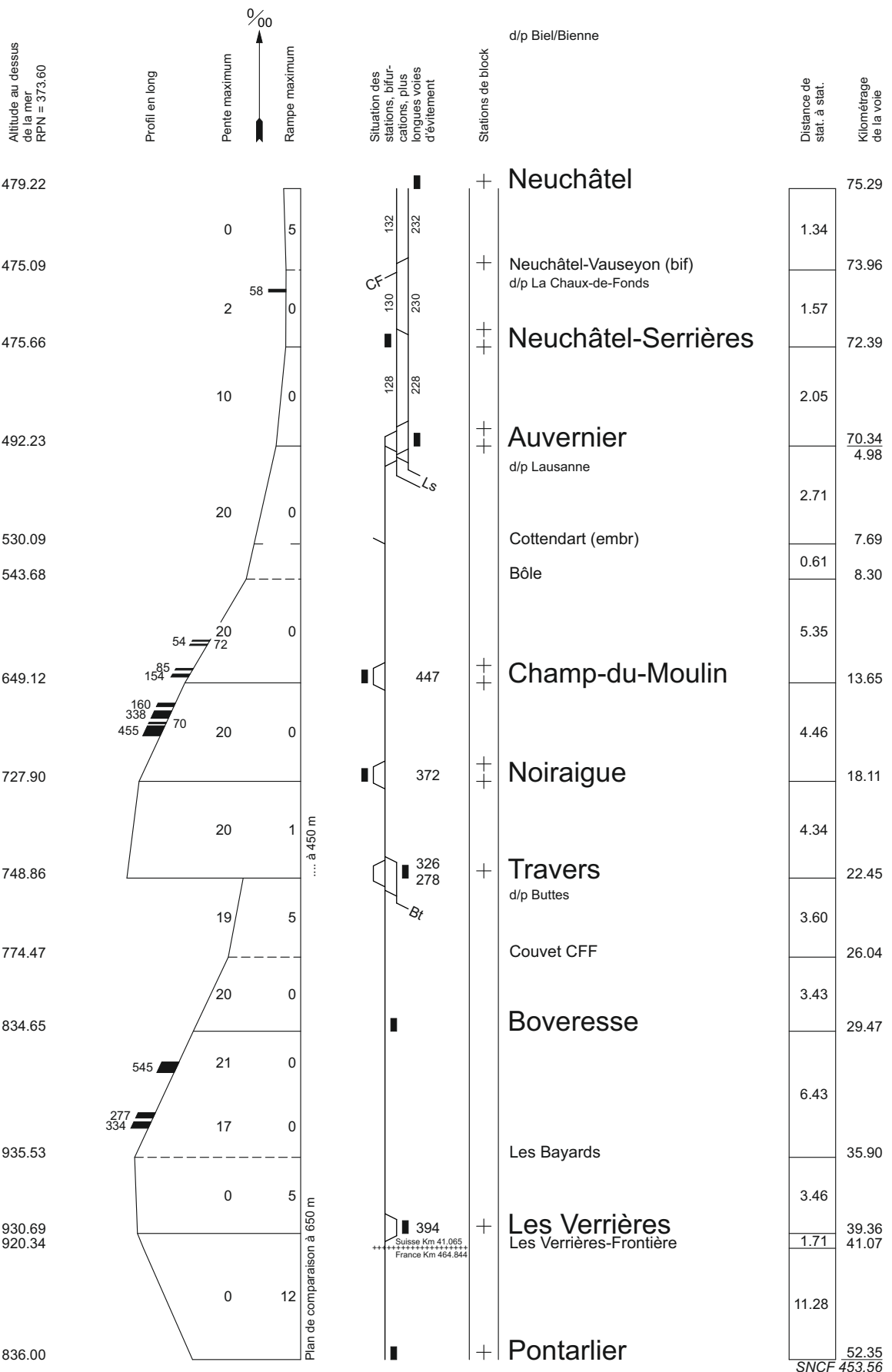

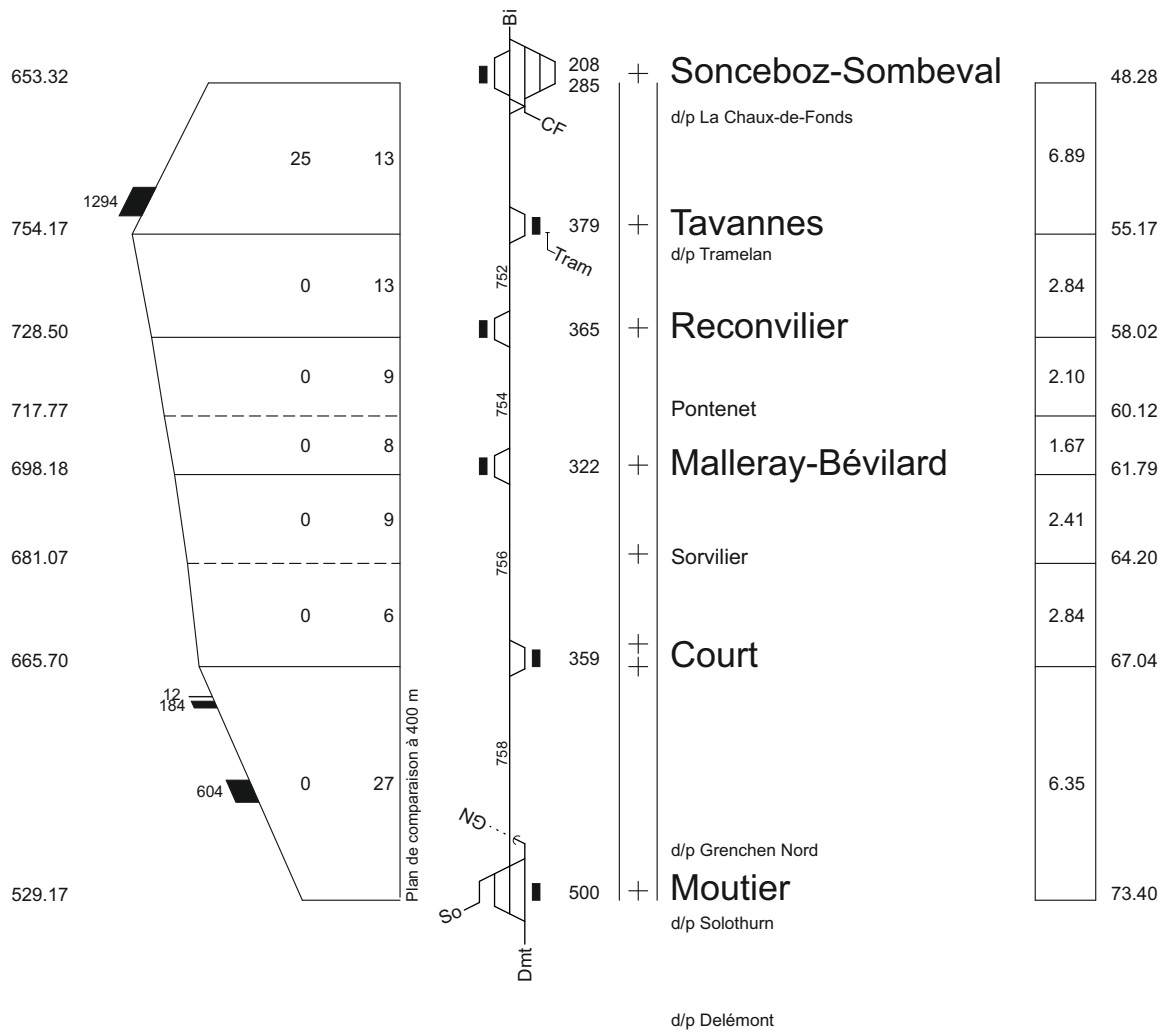
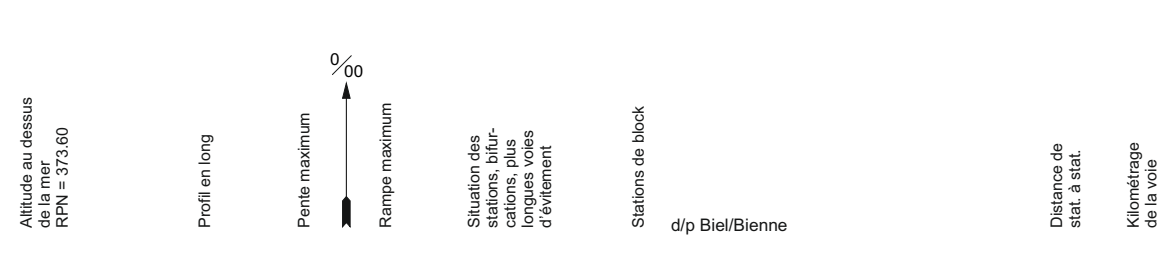
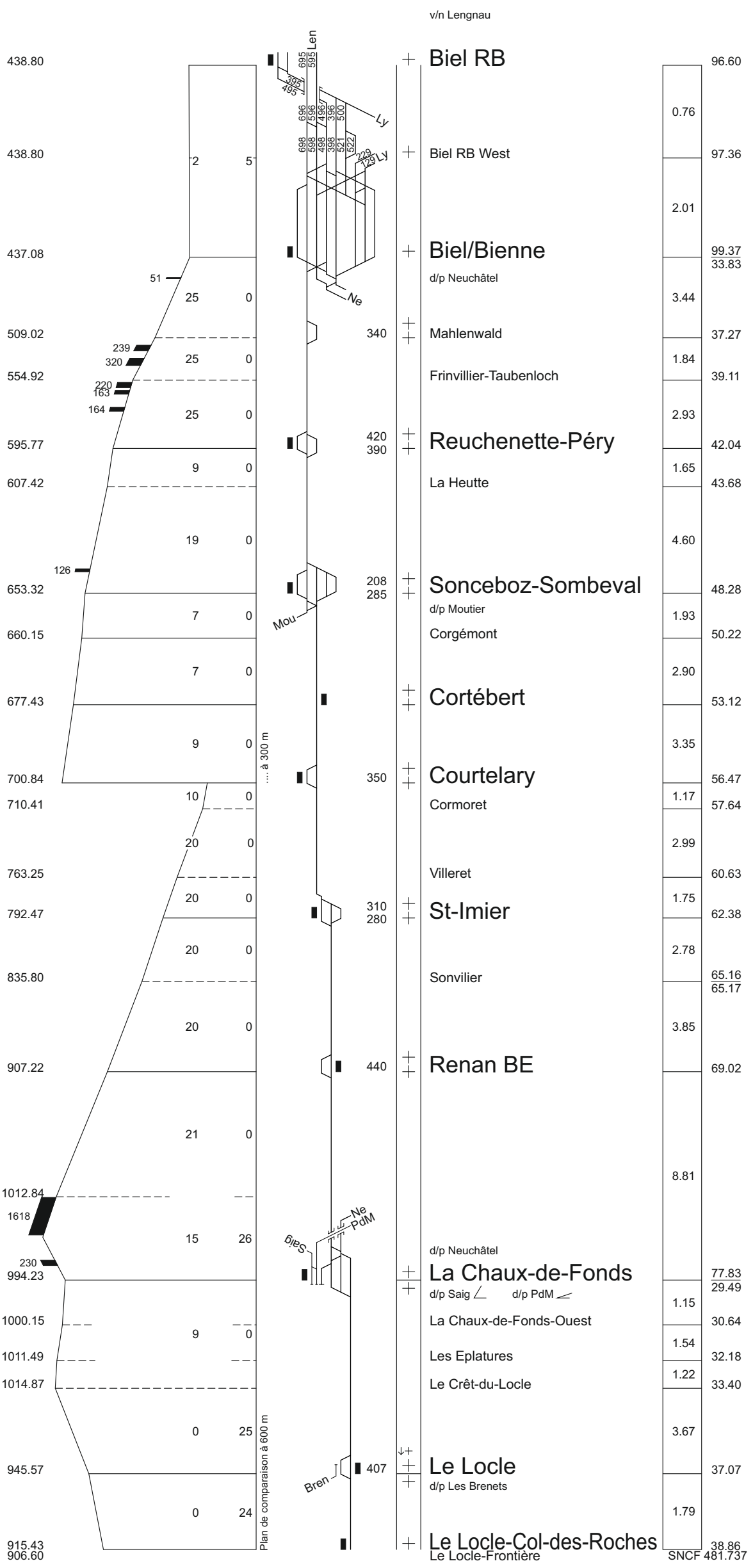

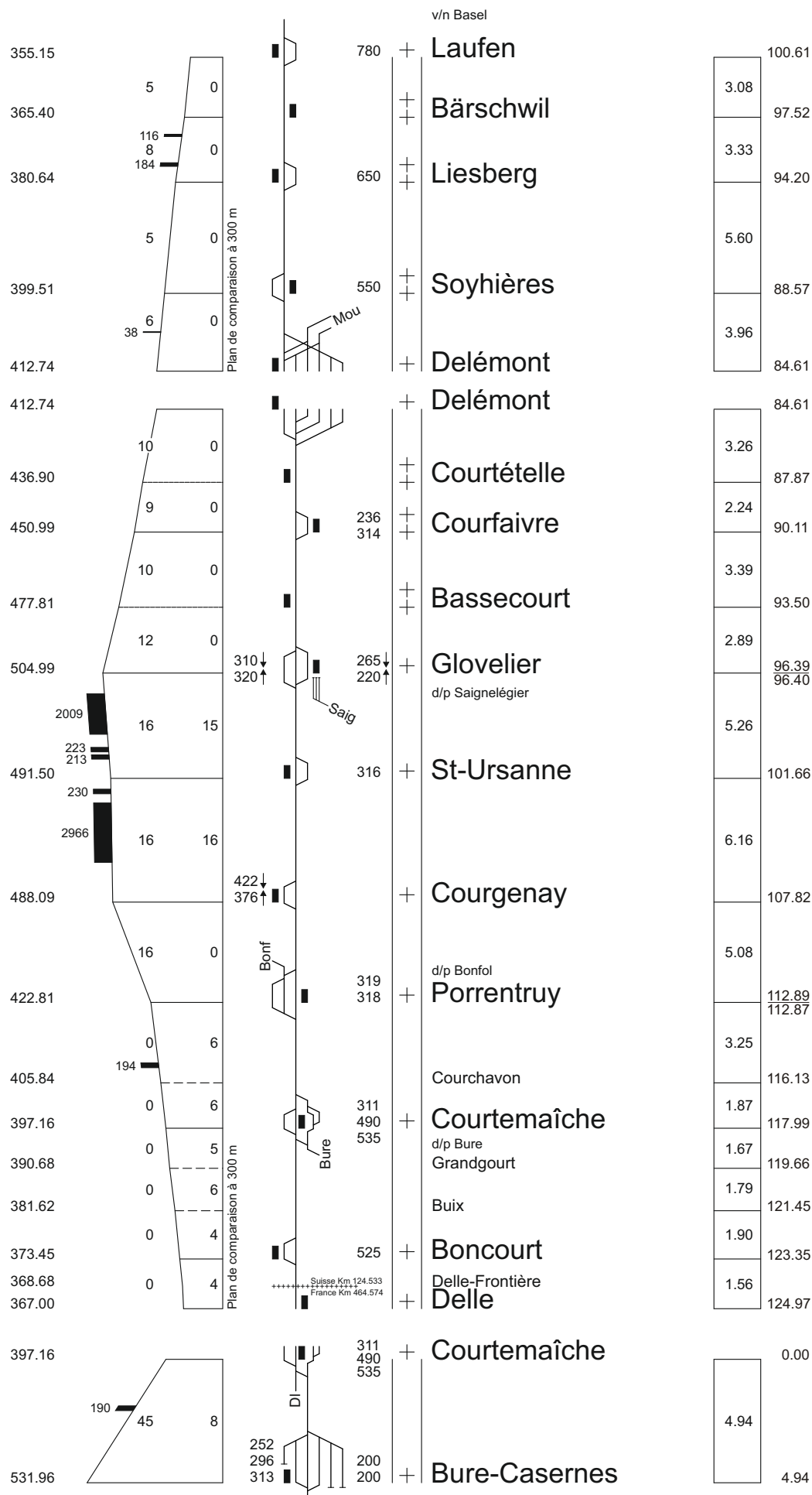
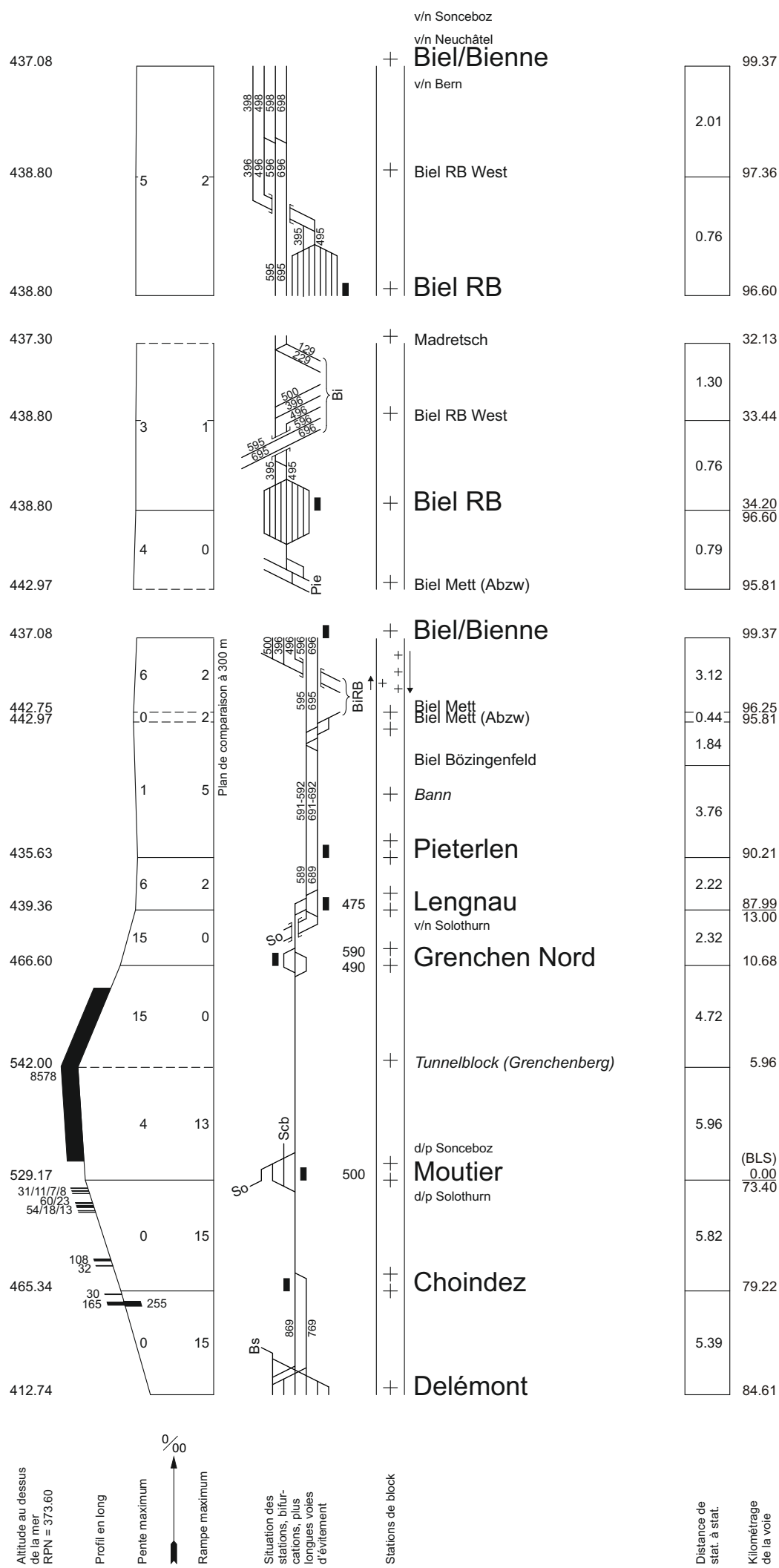

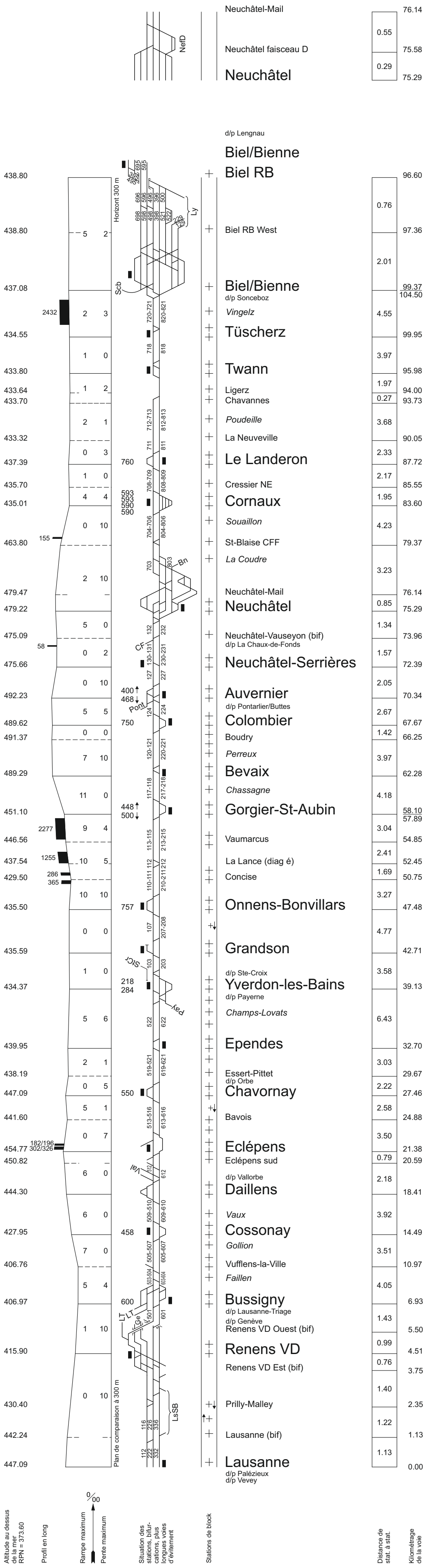



I-FN-FPA-RME

Ausgabe von 11.12.2016

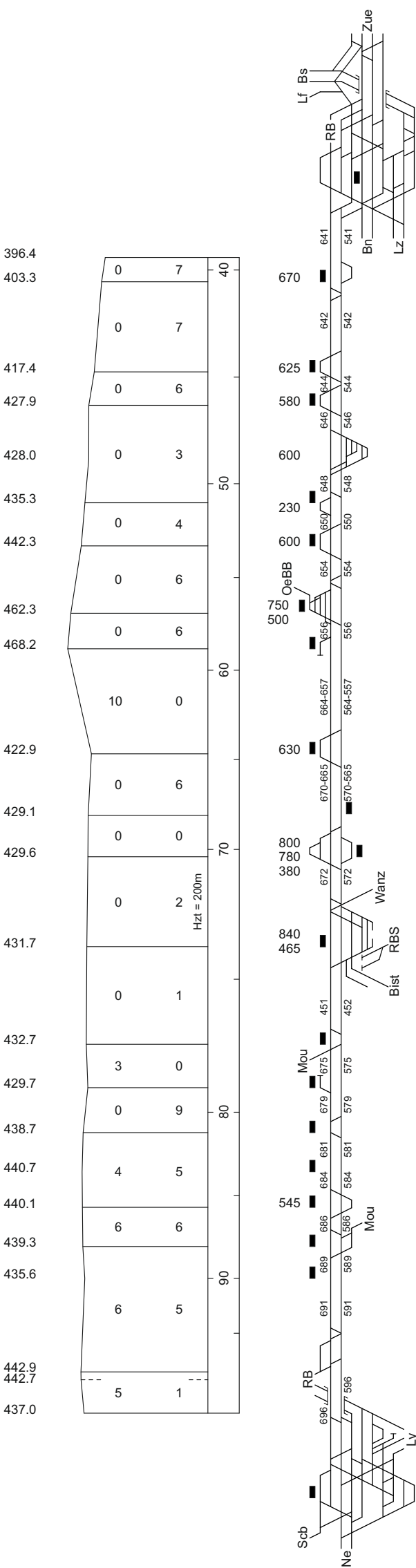
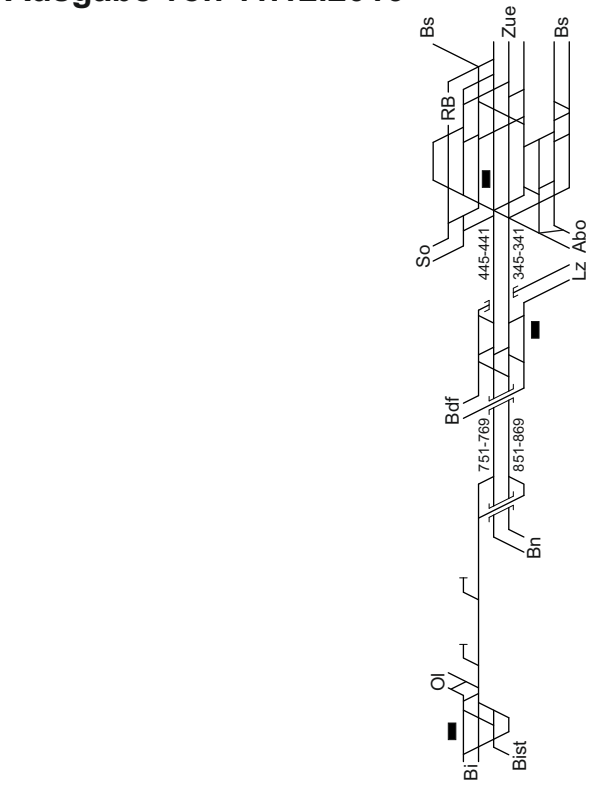

Meter
 Höhen über Meer
 RPN=373.60
 Längenprofil
 Grösste Steigung
 Grösstes Gefälle
 Kilometrierung
 Stationslage
 Abzweigungen
 Längste Ausweichgleise

v. u. n. Basel		
v. u. n. Aarau		
OLTEN PB		37.30
v. u. n. Luzern/Bern via ABO	5.86	
Rothrist		31.44
	19.39	
Wanzwil (Abzw)		12.05
Inkwil (Verzw)	6.56	
Subingen		5.49
Derendingen	2.45	3.04
SOLOTHURN	3.04	0.00

v. u. n. Aarau		
v. u. n. Basel		
OLTEN		
Olten Hammer	1.33	60.07
	2.42	58.74
Wangen bei Olten		56.32
Hägendorf	2.26	54.06
	2.14	51.92
Härkingen Paketpost		51.92
Egerkingen	1.66	50.26
Oberbuchsiten	2.32	47.94
v. u. n. Balsthal	5.21	
Oensingen		42.73
Niederbipp	1.98	40.75
	5.69	
Wangen a.d. Aare		35.06
	3.30	
Deitingen		31.76
Luterbach-Attisholz	2.75	29.01
v. u. n. Wanzwil	3.46	
SOLOTHURN		25.55
	0.96	
Solothurn West v. u. n. Moutier	0.88	24.59
Solothurn Allmend Bellach	2.00	21.71
Bellach Industrie	3.04	18.67
Selzach		16.48
Bettlach	2.19	16.48
Grenchen Süd v. u. n. Moutier	2.39	14.09
Lengnau	2.72	11.37
Pieterlen	2.22	9.15
	1.98	
Biel/Bienne Bözingenfeld/ Champs-de-Boujean	1.78	7.17
Biel Mett (Abzw)	1.83	5.39
Biel Mett	0.44	3.56
BIEL PB	3.12	0.00
v. u. n. Bern		
v. u. n. La Chaux-de-Fonds		
v. u. n. Neuchâtel		

Blockstationen bzw. Blockstellen
 Entf. von Stat. zu Stat.
 Entf. vom Ausgangspunkt

Höhen über Meer
RPN = 373.60

Längenprofil
Grösstes Gefälle
Grösste Steigung

Stationslage
Abzweigungen
Längste Ausweiche
Gleise

Blockstationen

Entf. von Stat. zu Stat.
Kilometrierung der Bahn

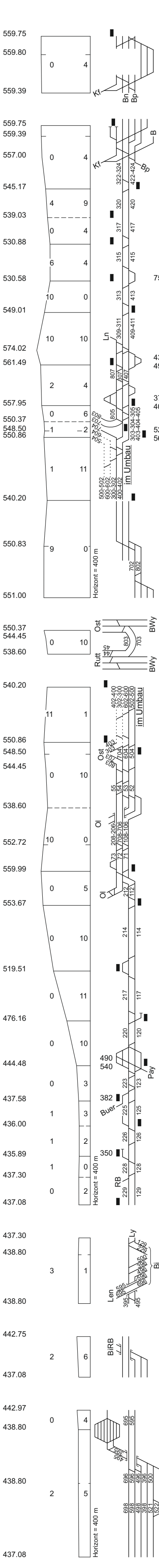

Thun Schadau (Abzw)			
+	Thun		137.02
	Thun Gruppe B	0.29	136.73
		0.58	
	Thun (Abzw)		136.15
+	Thun		137.02
	Thun (Abzw)	0.87	136.15
		1.52	134.63
		3.53	
	Uttigen		131.10
	<i>Kiesen</i>	2.79	
		2.57	
	Wichtrach		125.73
		3.60	
	Münsingen		122.13
		3.09	
	Rubigen		119.04
		3.67	
	v/n Langnau Gümligen Süd (Abzw)		115.37
	Gümligen	1.41	113.96
		3.19	
	Ostermundigen		110.77
	Wankdorf (Abzw)	1.28	109.48
	Bern Wankdorf	0.51	108.97
	Bern Wyler	0.39	108.58
			103.33
		2.80	
	Bern		106.16
			97.10
		0.78	
	Bern JKLM		96.32
		1.32	
	Bern Weyermannshaus		95.00
+	Wankdorf (Abzw)		103.17
	Löchligut Süd (Abzw)	0.67	102.50
	Löchligut	1.22	101.28
+	Bern		106.16
		2.83	
	Bern Wyler		103.33
	Bern Wankdorf	0.38	102.95
	Löchligut Süd (Abzw)	0.45	102.50
		1.22	
	Löchligut v/n Olten		101.28
		1.40	
	Zollikofen West (Spw)		99.88
			99.86
	Zollikofen		98.81
	v/n Olten		(7.46)
		2.66	
	Münchenbuchsee		10.12
		5.57	
	Schüpfen		15.69
		4.23	
	Suberg-Grossaffoltern		19.92
		3.44	
	Lyss		23.37
	v/n Payeme		
		2.79	
	Busswil		26.16
	v/n Büren a. d. Aare		
	v/n Studen Auto Studen BE		1.96
			28.12
		2.39	
	Brügg BE		30.51
		1.62	
	Madretsch v/n Biel RB		32.13
			33.07
	Biel/Bienne	1.46	98.84
			99.37
	Madretsch		32.13
	Biel RB West	1.30	33.44
			97.36
		0.76	
	Biel RB		96.60
	Biel Mett		96.25
		3.12	
	Biel/Bienne		99.37
	Biel Mett (Abzw)		95.81
	Biel RB	0.79	96.60
		0.76	
	Biel RB West		97.36
		2.01	
	Biel/Bienne		99.37

v/n Neuchâtel

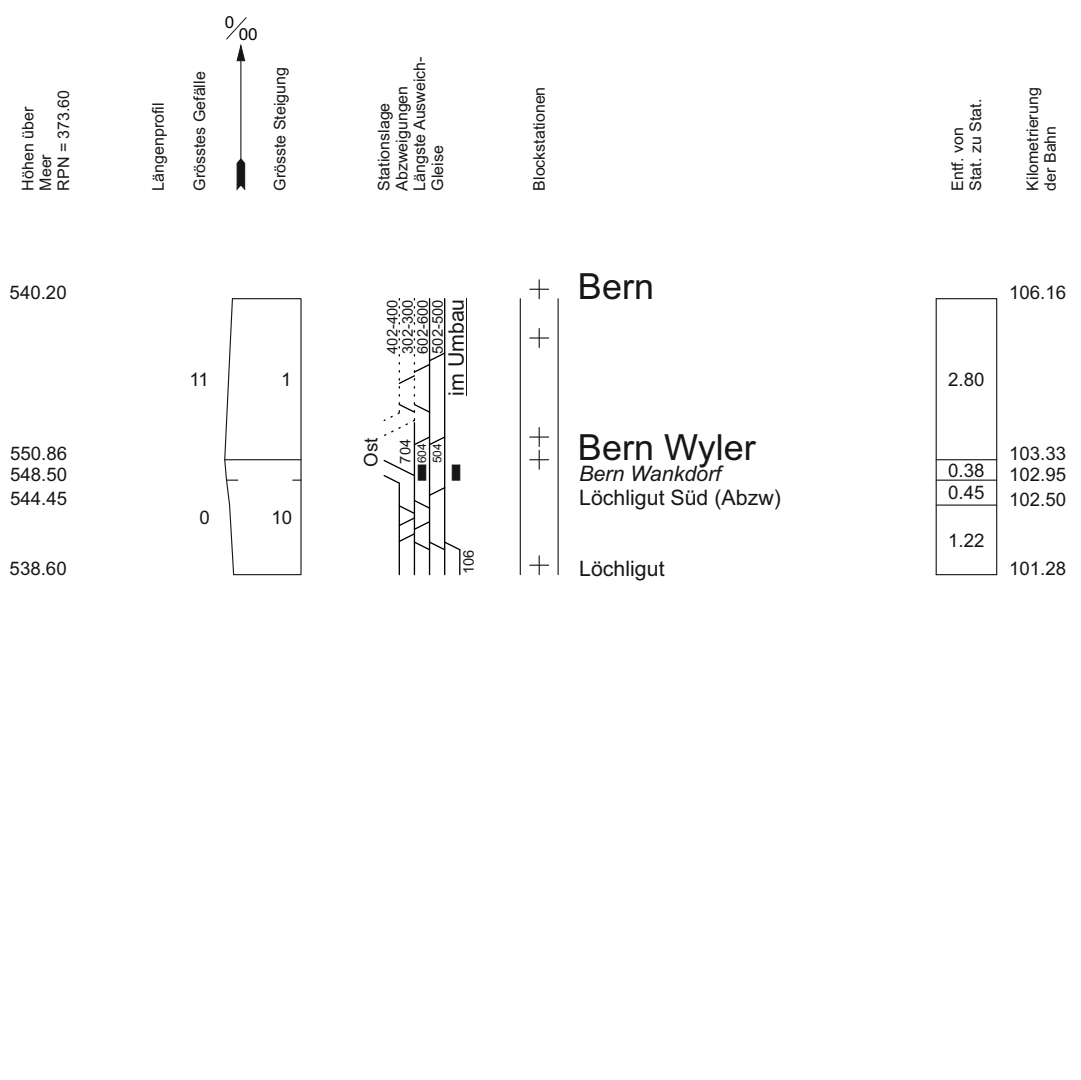
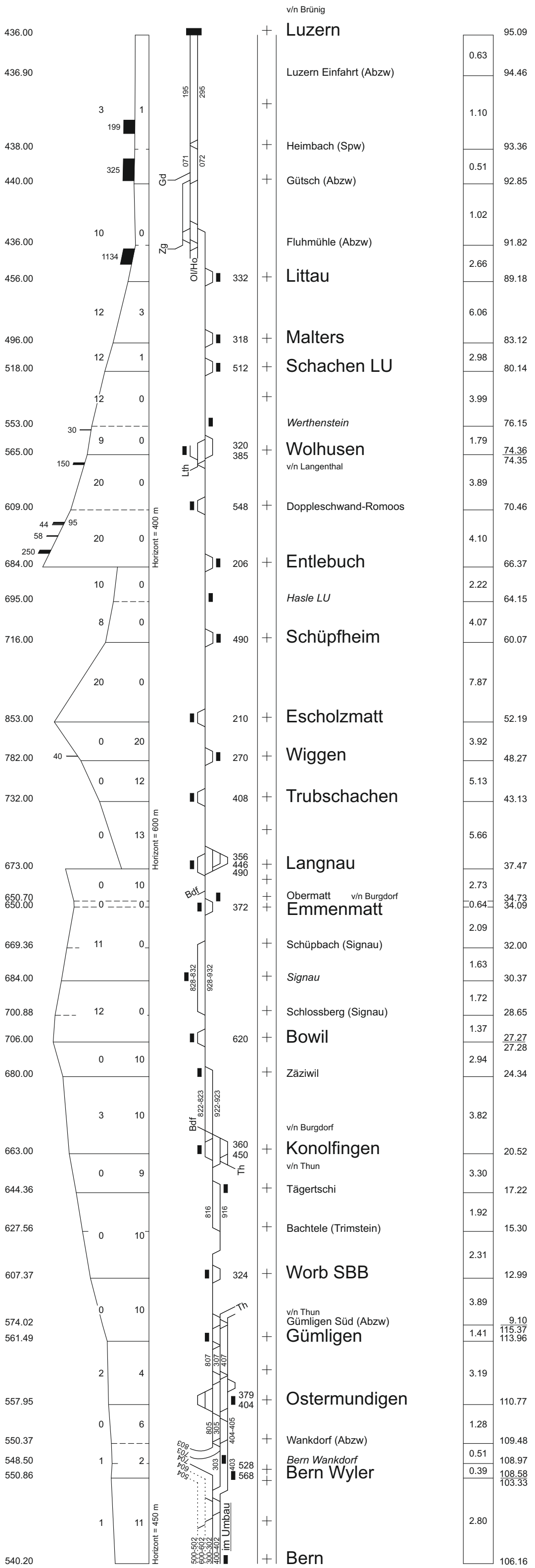

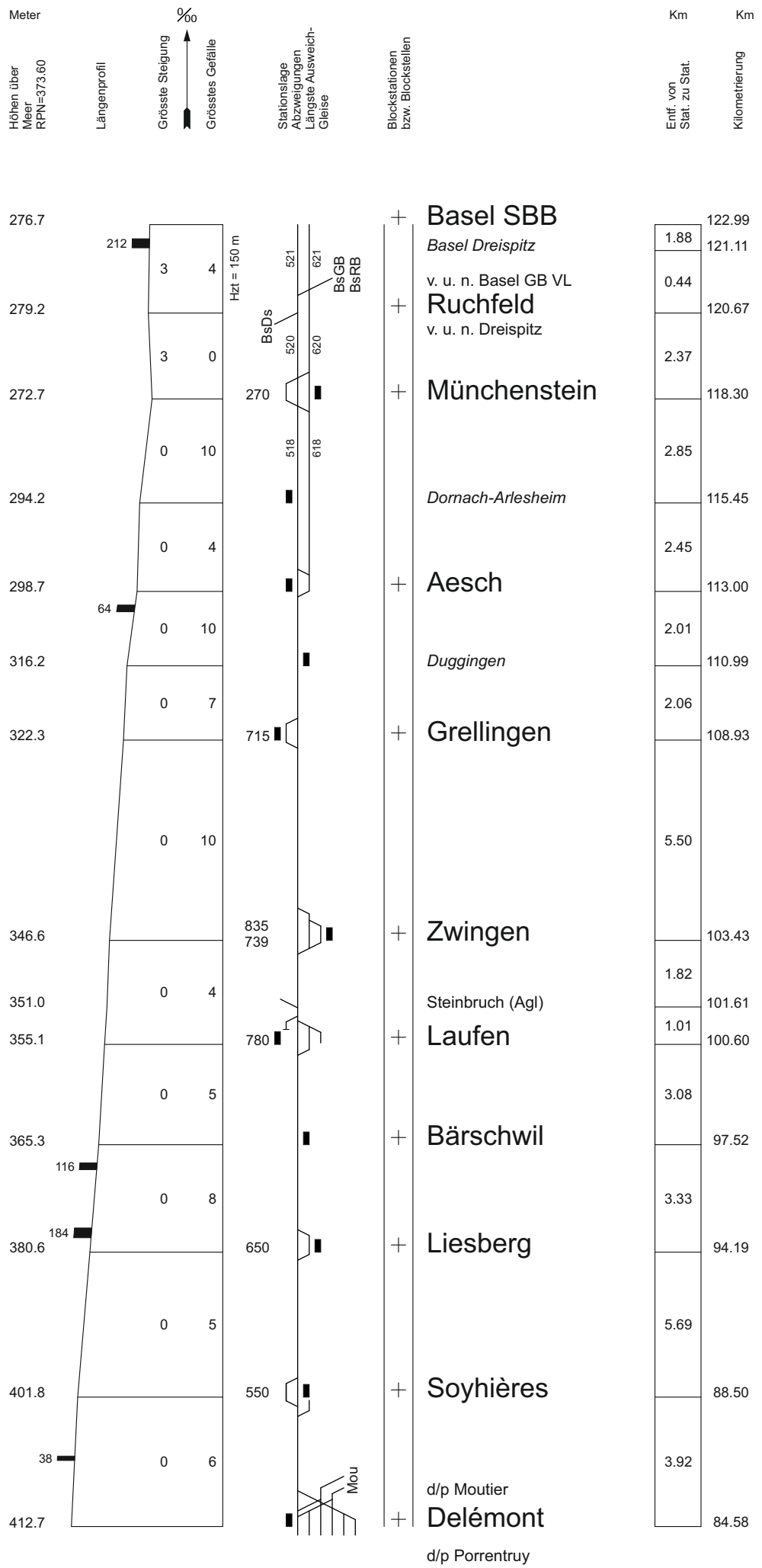

35 A

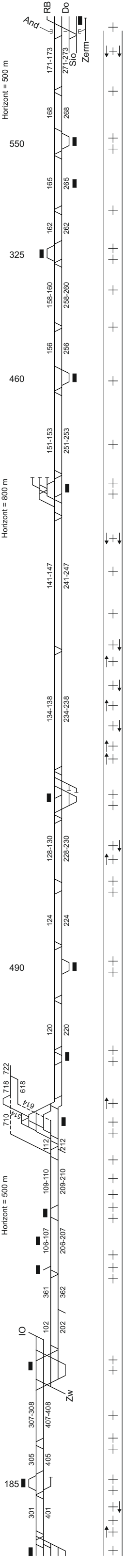
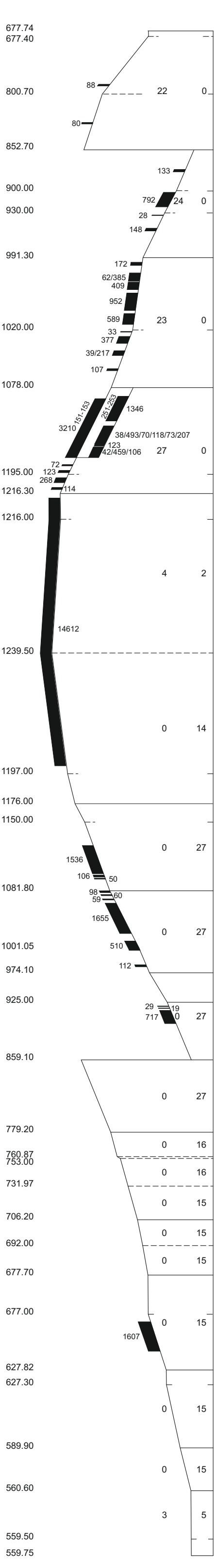

Station	Entf. von Stat. zu Stat.	Kilometrierung der Bahn
Brig		73.81
Brig-Lötschberg (Abzw)	-0.30	73.51
Mundbach (Spw)	3.16	70.35
Lalden	3.06	67.29
Eggerberg	2.29	64.99
Viktoria (Spw)	1.30	63.70
Ausserberg	2.43	61.27
Rarnerkumme (Spw)	3.98	61.28
Hohtenn	3.11	57.30
Stockgraben (Spw)	3.11	54.19
Goppenstein	4.73	49.46
Goppenstein Lötschberg (Spw)	1.02	48.44
Tunnelstation Lötschberg (Spw)	1.41	47.03
Eggenschwand (Spw)	7.27	39.76
Kandersteg	6.51	33.26
Bühl (Spw)	1.69	31.57
Felsenburg	1.07	30.50
Fürten (Spw)	3.72	26.78
Blausee-Mitholz	3.11	23.68
Grubi (Spw)	1.33	22.35
Kandergrund	1.70	20.65
Frutigen	3.20	17.45
Winklen (Spw)	3.92	13.54
Wengi (AnG)	1.51	12.03
Wengi-Ey (Abzw)	0.16	11.87
Reichenbach im Kandertal	1.59	10.28
Mülenen	1.93	9.97
Heustrich-Emdthal	1.44	9.97
Hondrich Süd (AnG)	1.44	8.29
Spiez	1.68	6.85
Spiez (Abzw)	2.17	5.16
Einigen	2.17	2.99
Gwatt	3.00	2.90
Thun Schadau (Abzw)	0.06	0.00
Thun	137.59	-0.106
Thun Gruppe B	1.00	9.78
Thun (Abzw)		8.90
Lerchenfeld		5.44
v/n Bern		3.10
		2.33
		2.62
		3.46
		0.89
		3.00
		2.99
		2.90
		2.17
		1.68
		1.44
		1.93
		1.59
		0.16
		1.51
		3.92
		17.45
		20.65
		22.35
		23.68
		26.78
		30.50
		31.57
		33.26
		39.76
		47.03
		48.44
		49.46
		54.19
		57.30
		61.27
		61.28
		63.70
		64.99
		67.29
		70.35
		73.51
		73.81

Wichtiger Hinweis:
Um die Lesbarkeit des Fahrplanes zu erhöhen, wurde auf die Darstellung der Verkehrsperioden (VP) bei den Zügen der Seite 28000-28999 verzichtet.

Höhen über Meer
RPN = 373.60

Längenprofil

Grösstes Gefälle
Grösste Steigung

Stationslage
Abzweigungen
Längste Ausweichgleise

Blockstationen

Entf. von Stat. zu Stat.
Kilometrierung der Bahn

Höhen über Meer
RPN = 373.60

Längenprofil
Grösstes Gefälle
Grösste Steigung

0/00

Stationslage
Abzweigungen
Längste Ausweichgleise

Blockstationen

Entf. von Stat. zu Stat.
Kilometerierung der Bahn

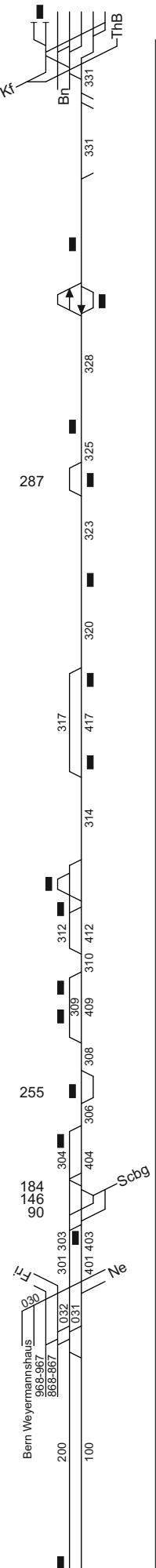
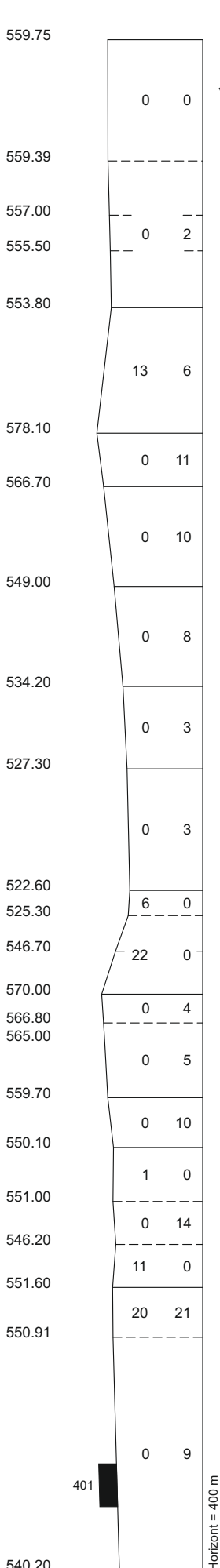

Station	Entf. von Stat. zu Stat.	Kilometerierung der Bahn
Bern	0.86	97.18
Bern JKLM		96.32
Bern Weyermannshaus (Spw)	1.41	94.92
Bern Holligen	0.48	2.71
Bern Ausserholligen GBS	0.41	3.12
Bern Fischermätteli (Abzw)	0.40	3.52
Köniz Liebefeld	0.72	5.00
Köniz	2.08	5.71
Moos	1.08	7.80
Mittelhäusern	1.83	12.82
Schwarzwasserbrücke	3.18	14.66
Lanzenhäusern	3.04	17.83
Schwarzenburg	3.04	20.87
Bern	0.86	97.18
Bern Weyermannshaus (Spw)	2.23	94.92
Bern Holligen	0.41	2.71
Bern Europaplatz	0.40	3.12
Bern Fischermätteli (Abzw)	1.57	3.52
Bern Weissenbühl	1.48	5.09
Wabern bei Bern	1.70	6.57
Breitenacker (Spw)	0.51	8.27
Kehrsatz Nord	0.89	8.77
Kehrsatz	1.21	9.67
Falkenhaus (Spw)	1.05	10.87
Belp Steinbach	0.78	11.92
Belp	3.43	16.13
Toffen	2.34	18.47
Kaufdorf	2.88	21.34
Thurnen	2.86	24.20
Burgstein-Wattenwil	1.52	25.72
Seftigen	3.58	29.30
Uetendorf	1.70	30.99
Uetendorf Allmend	1.08	32.08
Lerchenfeld	1.53	33.61
Thun (Abzw)	0.87	34.48
Thun		34.48

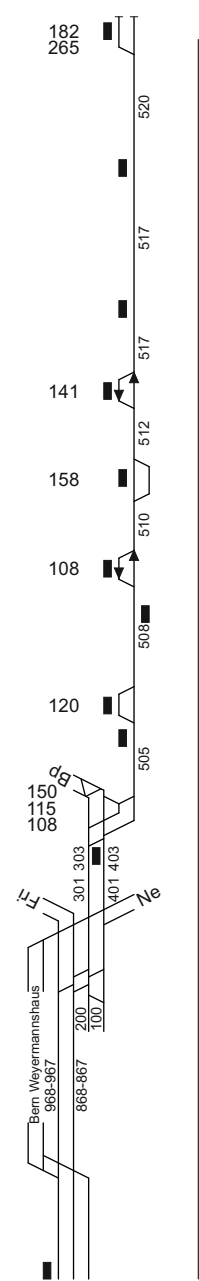
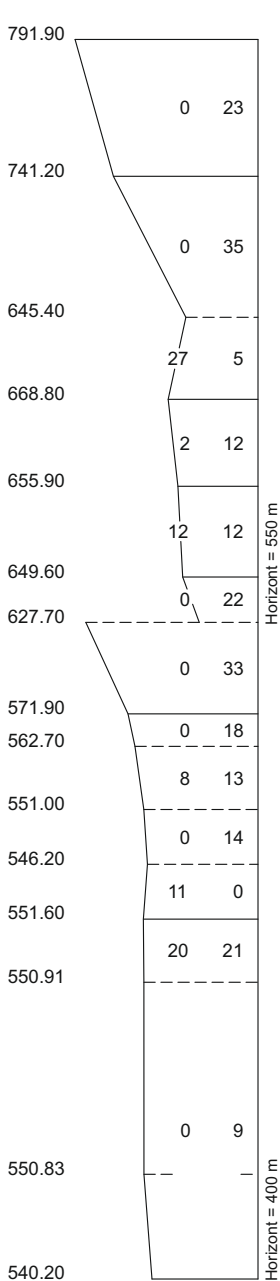

Station	Entf. von Stat. zu Stat.	Kilometerierung der Bahn
Bern	0.86	97.18
Bern JKLM		96.32
Bern Weyermannshaus (Spw)	2.23	94.92
Bern Holligen	0.41	2.71
Bern Ausserholligen GBS	0.40	3.12
Bern Fischermätteli (Abzw)	1.47	3.52
Köniz Liebefeld	0.72	5.00
Köniz	2.08	5.71
Moos	1.08	7.80
Mittelhäusern	1.83	12.82
Schwarzwasserbrücke	3.18	14.66
Lanzenhäusern	3.04	17.83
Schwarzenburg	3.04	20.87

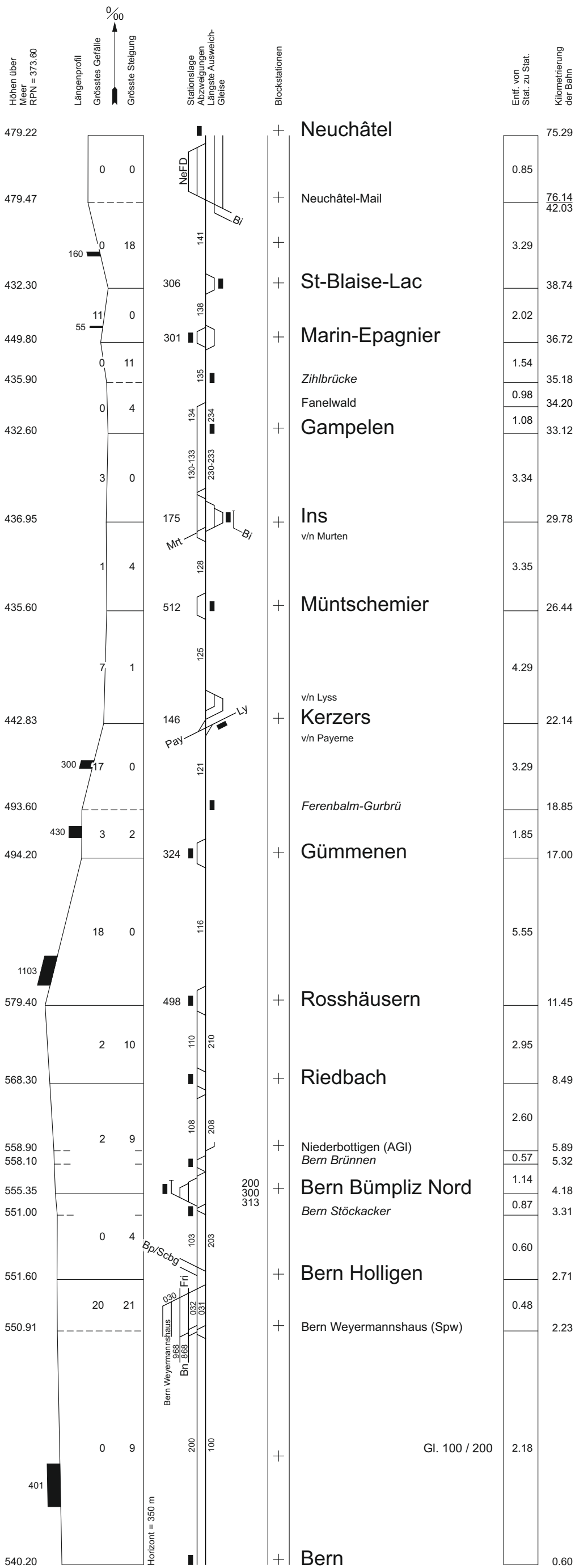

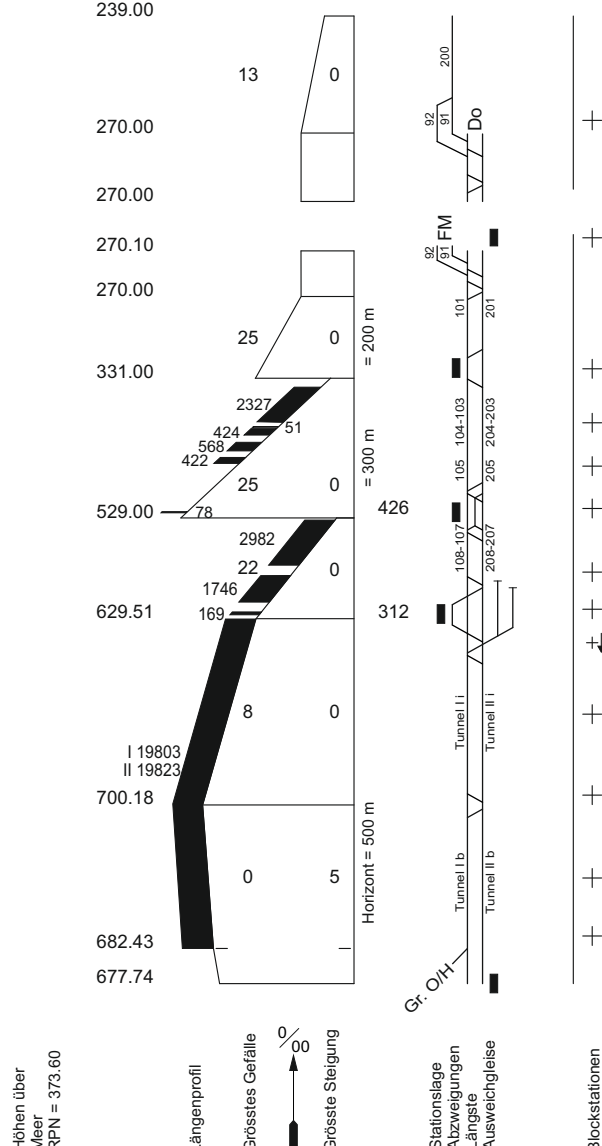

Höhen über Meer RPN = 373.60
Längenprofil
Grösstes Gefälle
Grösste Steigung
Horizont = 500 m
Horizont = 300 m
Horizont = 200 m
Stationslage
Abzweigungen
Längste Auswechseleise
Blockstationen

Domodossola II	191.34
Domodossola FM	186.12
Domodossola (bif)	185.04
Domodossola	186.28
Domodossola (bif)	185.04
Preglia	182.45
Varzo	173.75
Iselle di Trasquera	167.48
Staz. della Galleria Sempione	156.35
Brig Tunnel	147.15
Brig	145.55

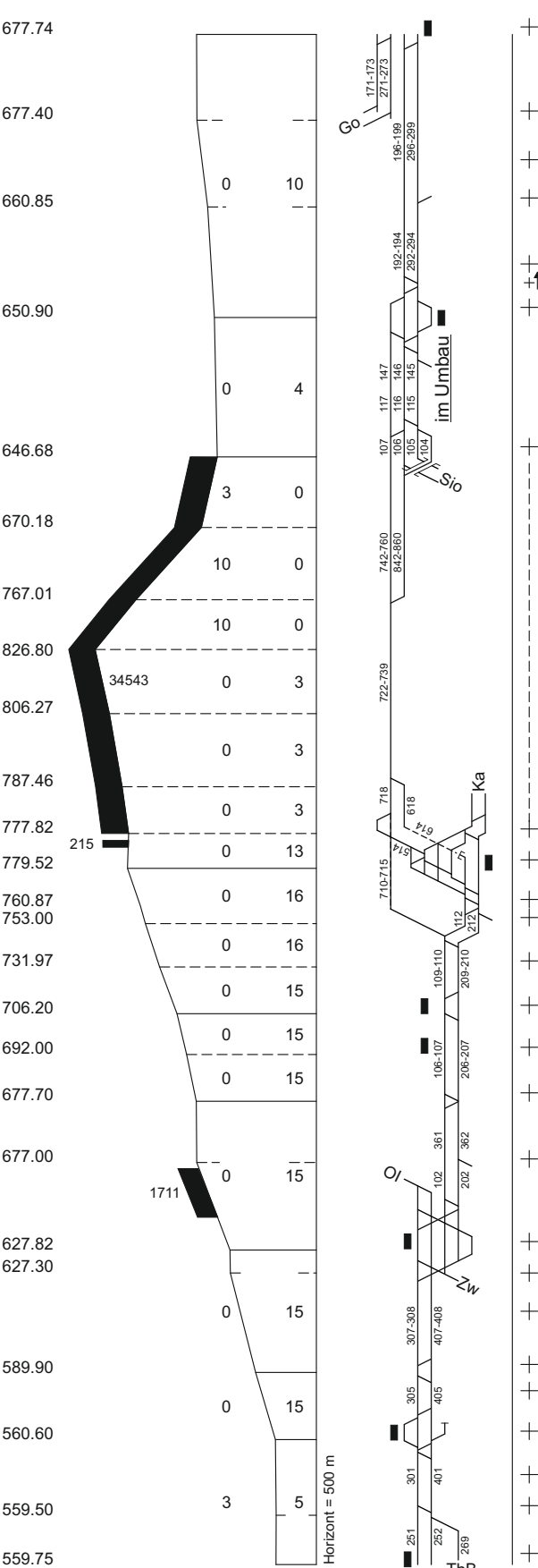

Höhen über Meer RPN = 373.60
Längenprofil
Grösstes Gefälle
Grösste Steigung
Horizont = 500 m
Horizont = 400 m
Stationslage
Abzweigungen
Längste Auswechseleise
Blockstationen

Brig	145.55
Brig Lötschberg (Abzw)	145.25
Gamsen SBB	141.44
Visp	136.73
Visp West (Spw)	135.90
St. German (Abzw)	133.40
Lötschen	43.84
Ferden (Spw)	35.22
Mitholz	22.02
Adelrain (Abzw)	15.76
Frutigen Nordportal (Abzw)	14.65
Frutigen	13.54
Winklen (Spw)	12.03
Wengi (AGI)	11.87
Wengi-Ey (Abzw)	10.28
Reichenbach i/K.	8.29
Mülenen	6.85
Heustrich-Emdthal	5.16
Hondrich Süd (AGI)	2.99
Spiez	0.00
Spiez (Abzw)	8.90
Einigen	5.44
Gwatt	3.10
Thun Schadau (Abzw)	0.49
Thun	137.59

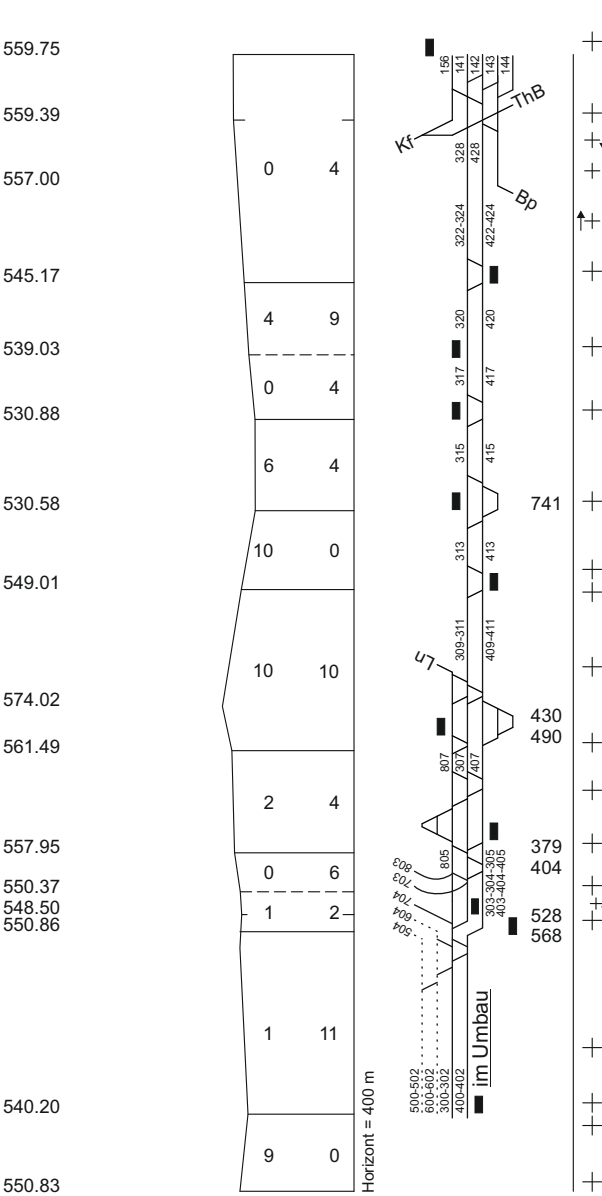

Höhen über Meer RPN = 373.60
Längenprofil
Grösstes Gefälle
Grösste Steigung
Horizont = 400 m
Stationslage
Abzweigungen
Längste Auswechseleise
Blockstationen

Thun	137.02
Thun (Abzw)	136.15
Uttigen	134.63
Kiesen	128.30
Wichtrach	125.73
Münsingen	122.13
Rubigen	119.04
Allmendingen	115.37
Gümligen Süd (Abzw)	113.96
Gümligen	110.77
Ostermundigen	109.48
Wankdorf (Abzw)	108.97
Bern Wankdorf	108.58
Bern Wyler	103.33
Bern	106.16
Bern JKLM	96.32

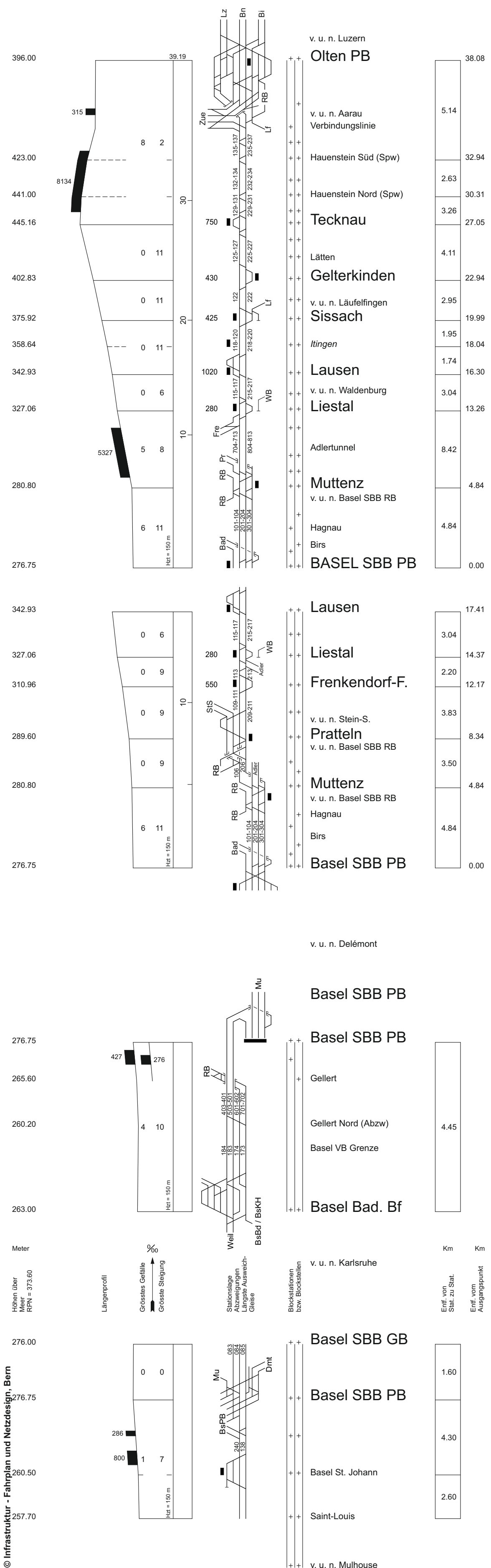

v. u. n. Brünig

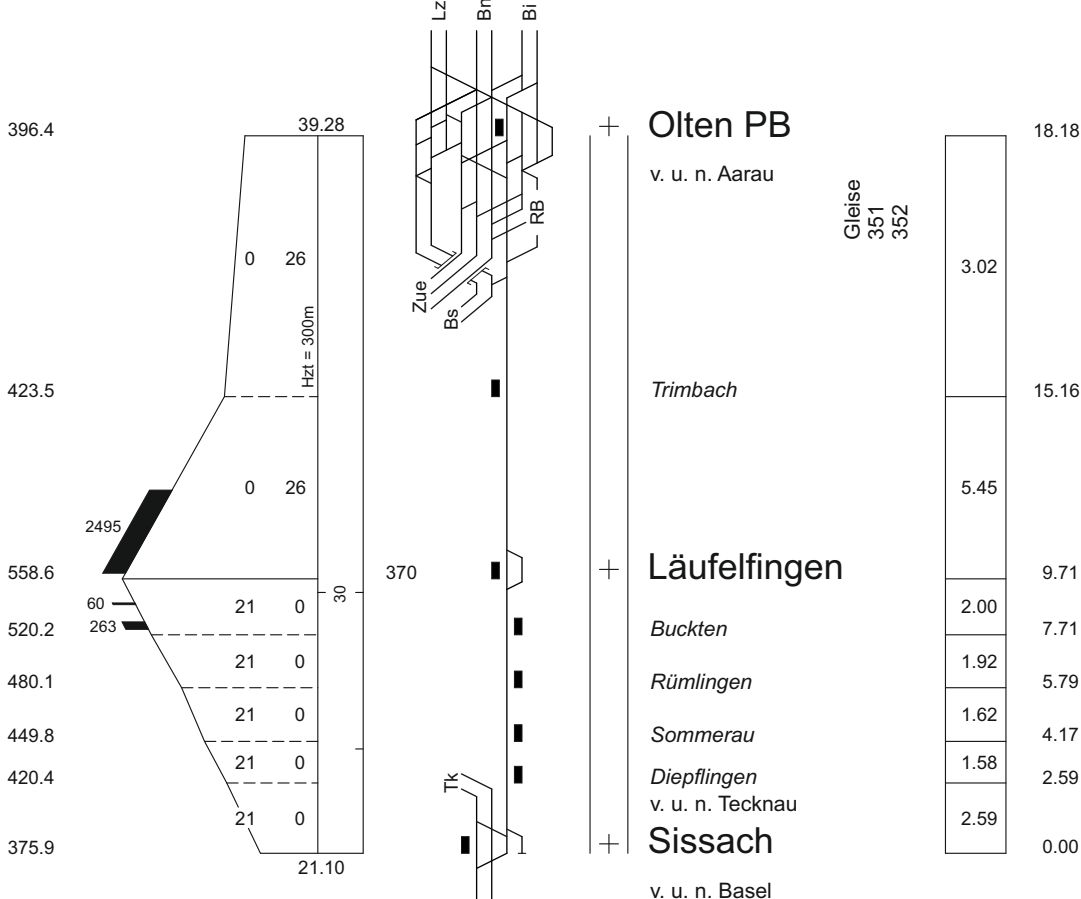
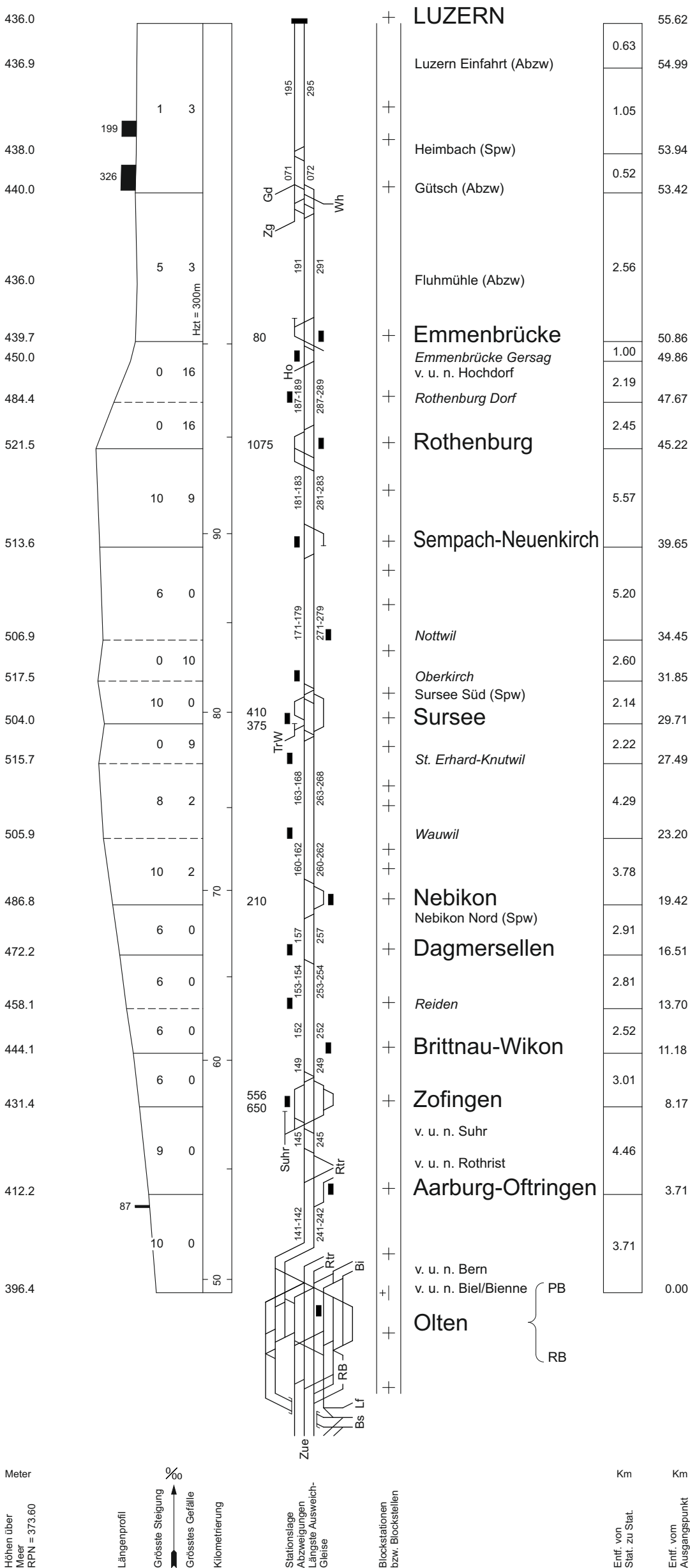

v. u. n. Brünig

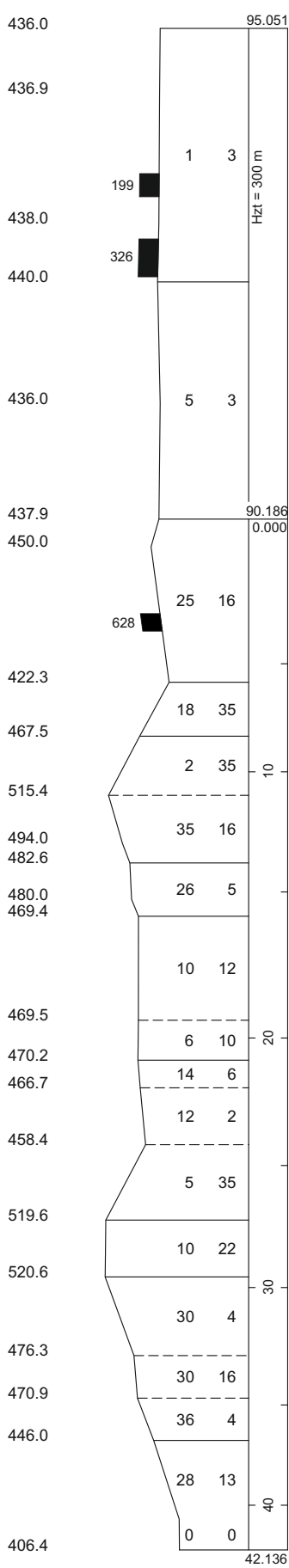

Station	Entf. von Stat. zu Stat. (km)	Entf. vom Ausgangspunkt (km)
LUZERN	46.91	
Luzern Einfahrt (Abzw)	0.63	46.28
Heimbach (Spw)	1.05	45.23
Gütsch (Abzw)	0.52	44.71
Fluhmühle (Abzw)	2.56	
Emmenbrücke	42.15	
Emmenbrücke Gersag v. u. n. Olten	1.00	41.15
Waldibrücke	4.86	36.29
Eschenbach	2.72	33.57
Ballwil	2.42	31.15
Hochdorf Schönau	1.89	29.26
HOCHDORF	0.84	28.42
Baldegg Kloster	1.63	26.79
Baldegg	0.57	26.22
Gelfingen	3.44	22.78
Hitzkirch	1.43	21.35
Ermensee	1.08	20.27
Mosen	2.27	18.00
BEINWIL am See	3.06	14.94
Birrwil	2.31	12.63
Boniswil	3.57	9.06
Hallwil	1.53	7.53
Seon	2.25	5.28
LENZBURG	5.28	0.00

Meter
Höhen über Meer
RPN = 373.60

Längenprofil
Grösste Steigung
Grösstes Gefälle
Kilometrierung

Stationslage
Abzweigungen
Langste Ausweichgleise

Blockstationen bzw. Blockstellen

Km
Entf. von Stat. zu Stat.
Entf. vom Ausgangspunkt

Rupperswil

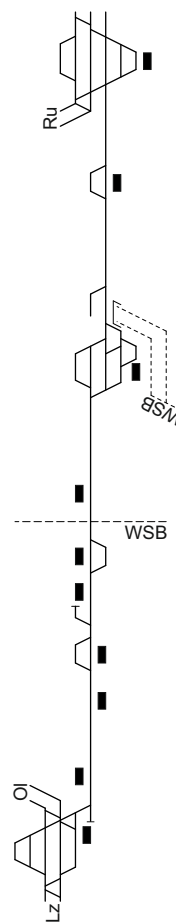
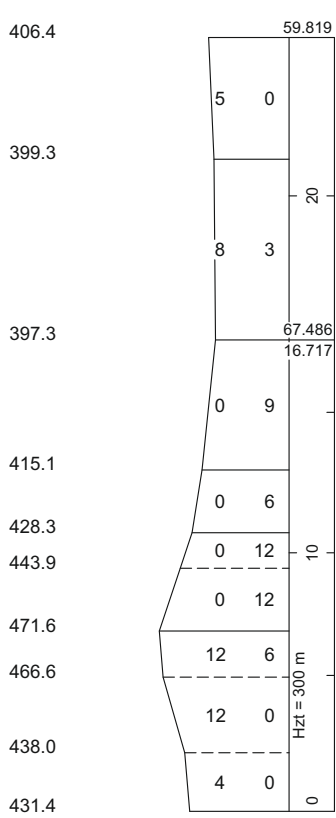

Station	Entf. von Stat. zu Stat. (km)	Entf. vom Ausgangspunkt (km)
LENZBURG	24.38	
Hunzenschwil	3.44	20.94
Suhr Migros	3.20	17.74
Suhr	1.02	16.72
Oberentfelden	3.09	13.63
Kölliken	2.74	10.89
Kölliken Oberdorf	1.61	9.28
Kölliken Sondermülldeponie	2.72	
Safenwil	2.72	6.56
Walterswil-Striegel	1.62	4.94
Küngoldingen v. u. n. Olten	2.65	2.29
ZOFINGEN	2.29	0.00

v. u. n. Luzern

Ausgabe von 11.12.2016

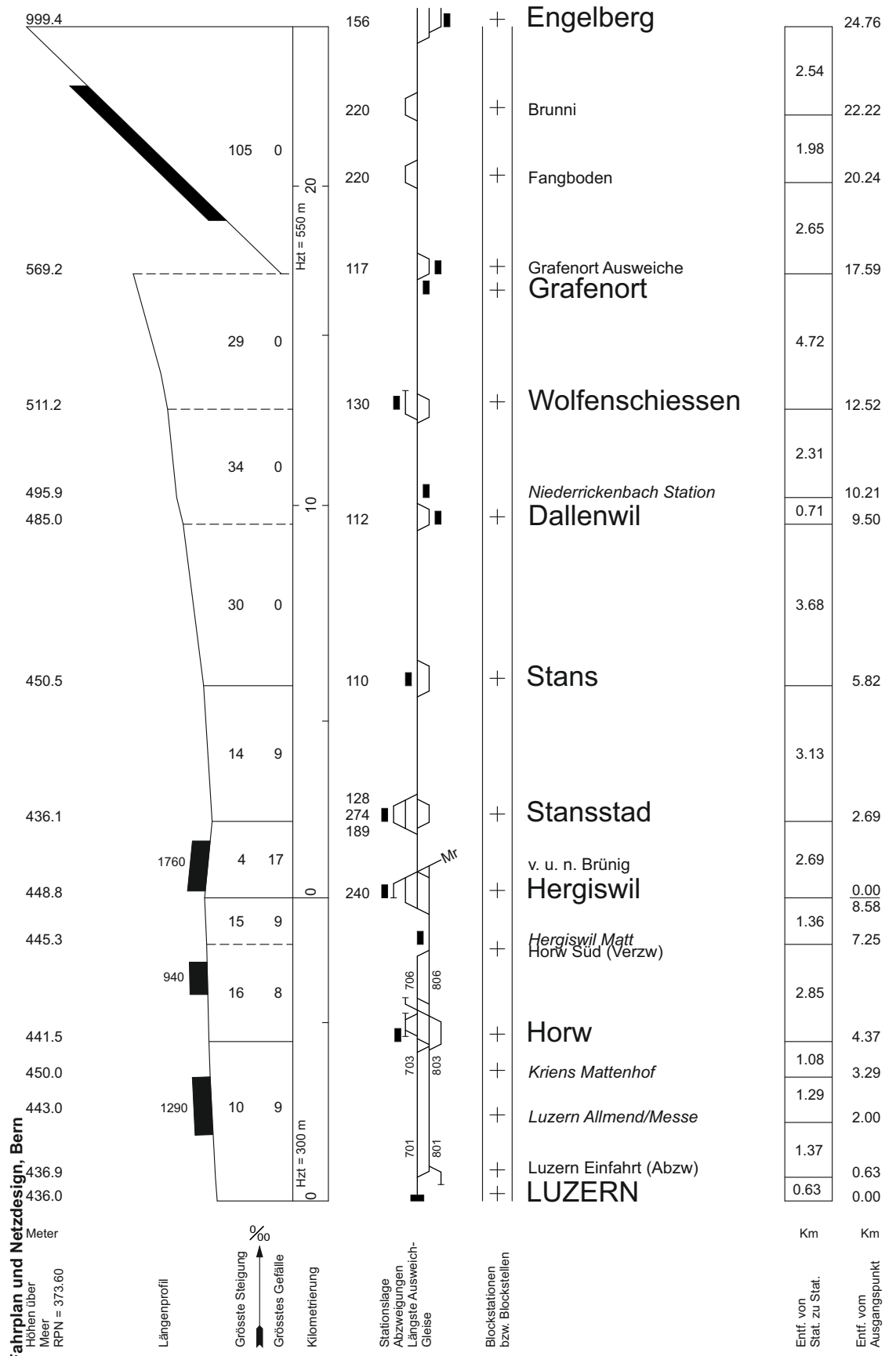

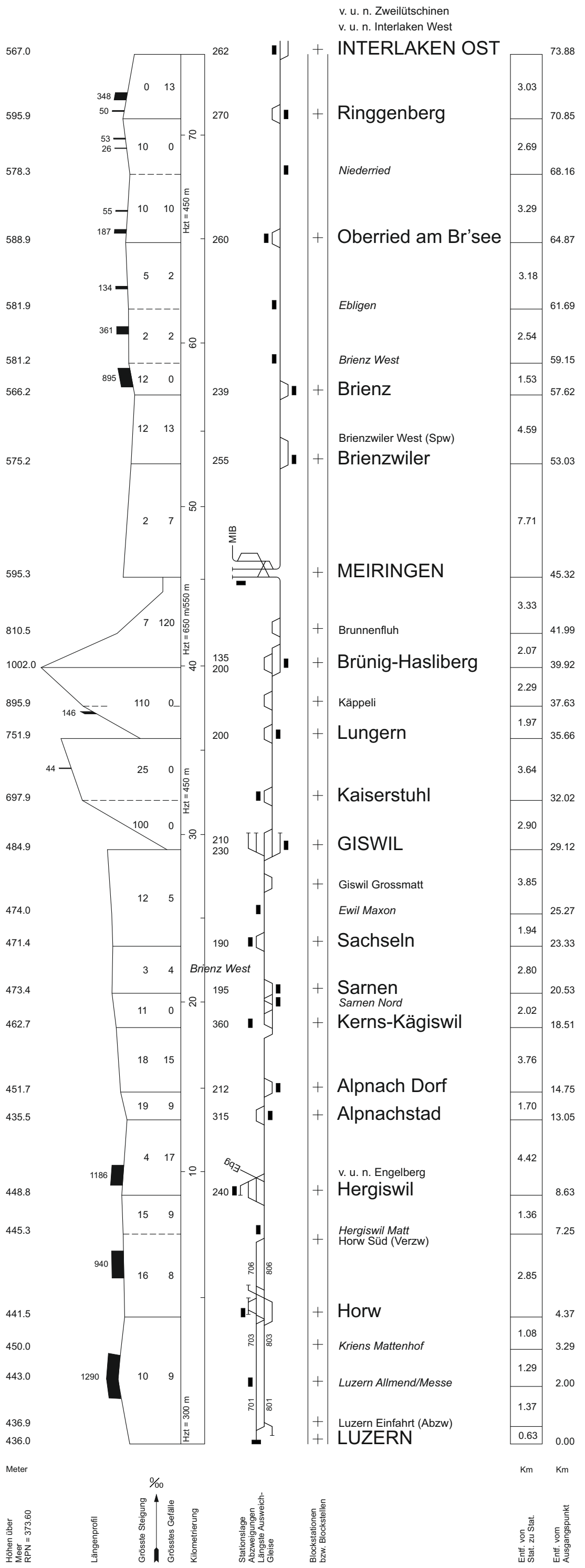

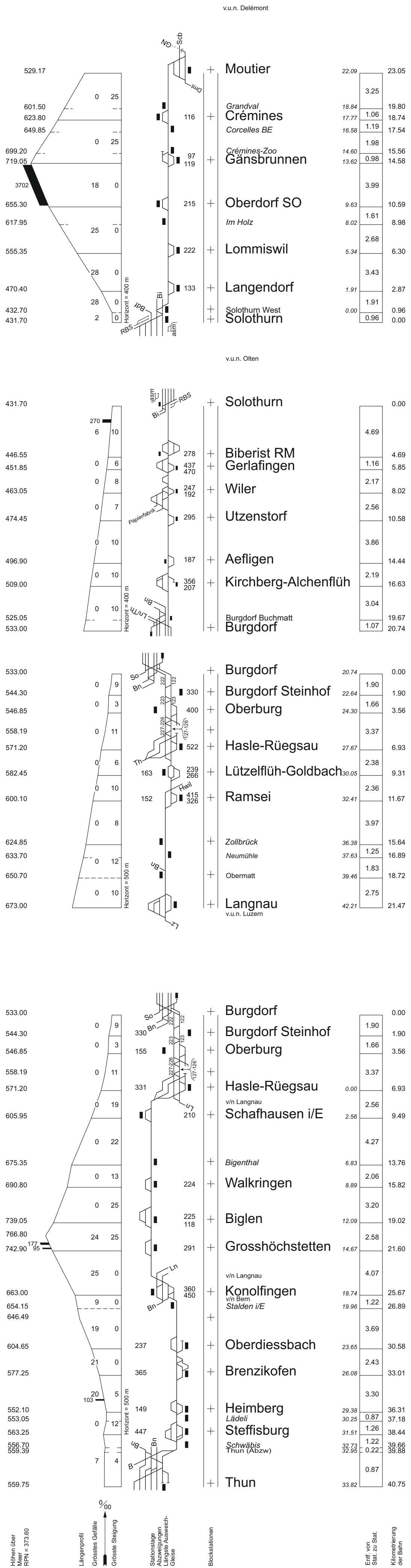

v.u.n. Delémont

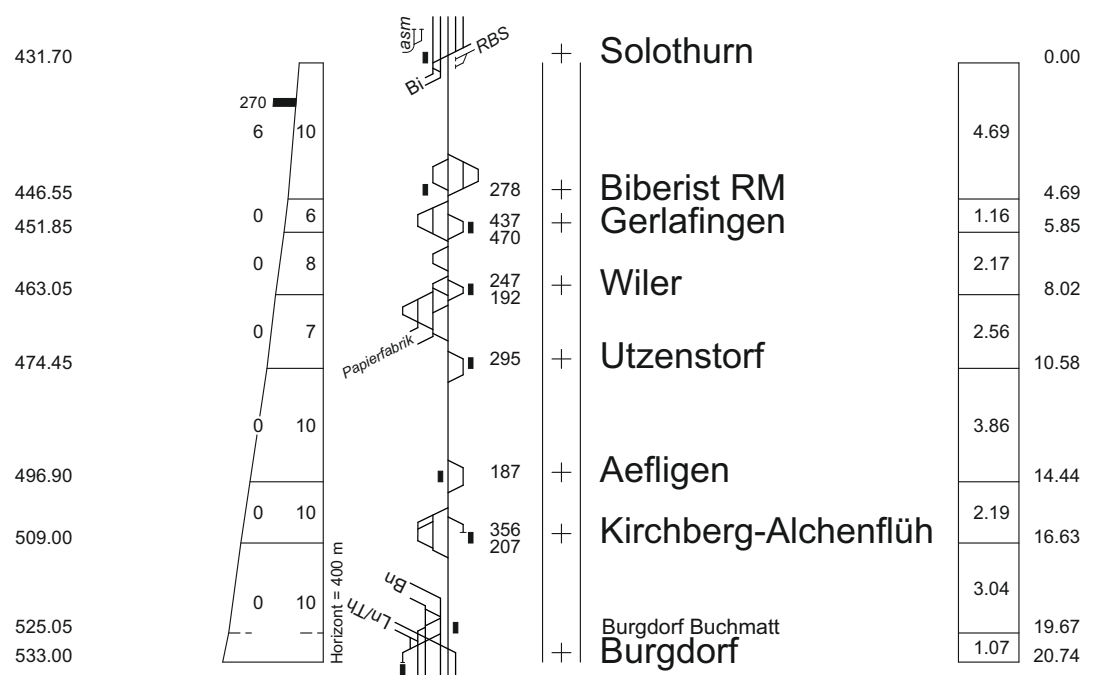

v.u.n. Olten

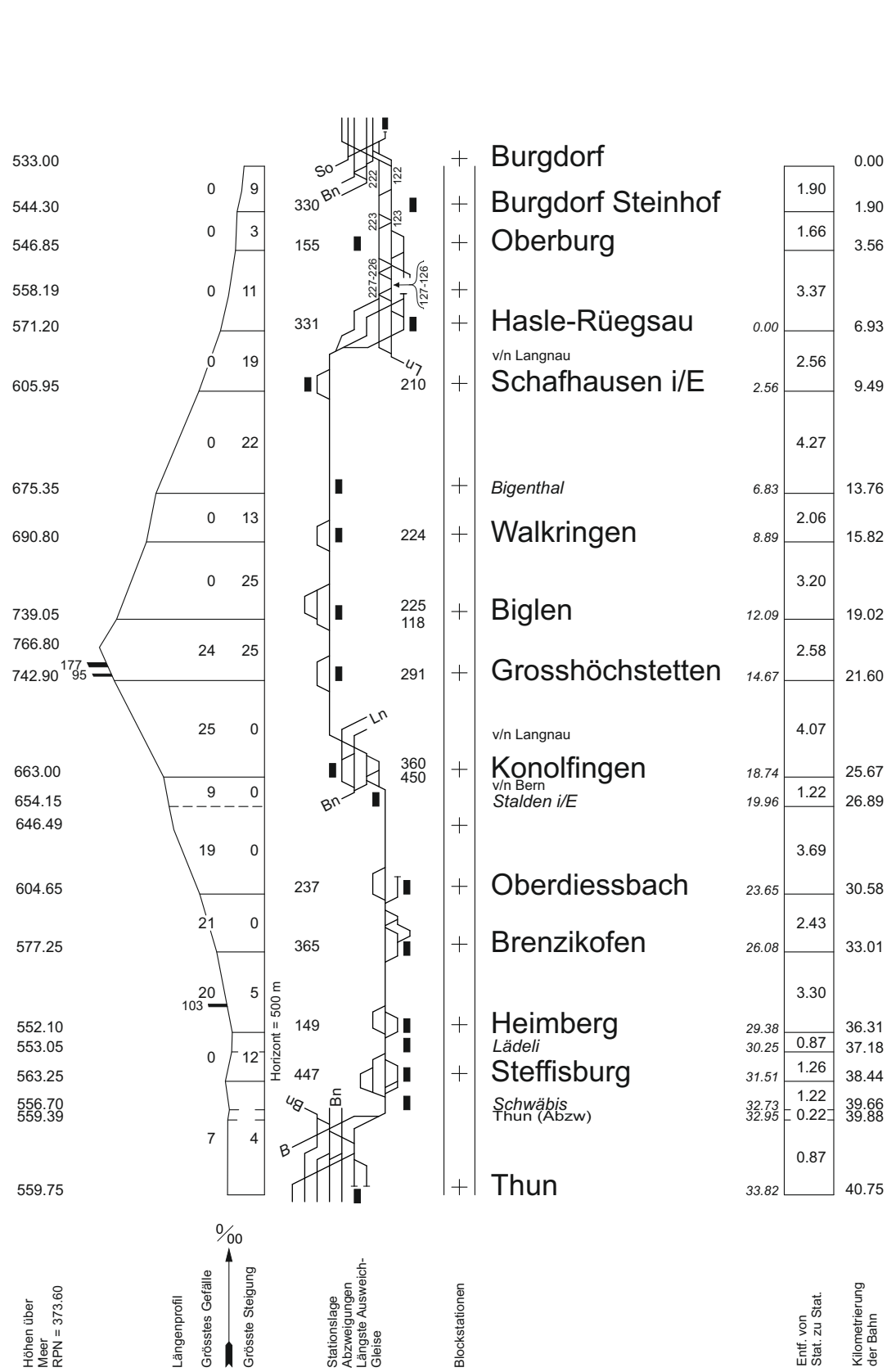
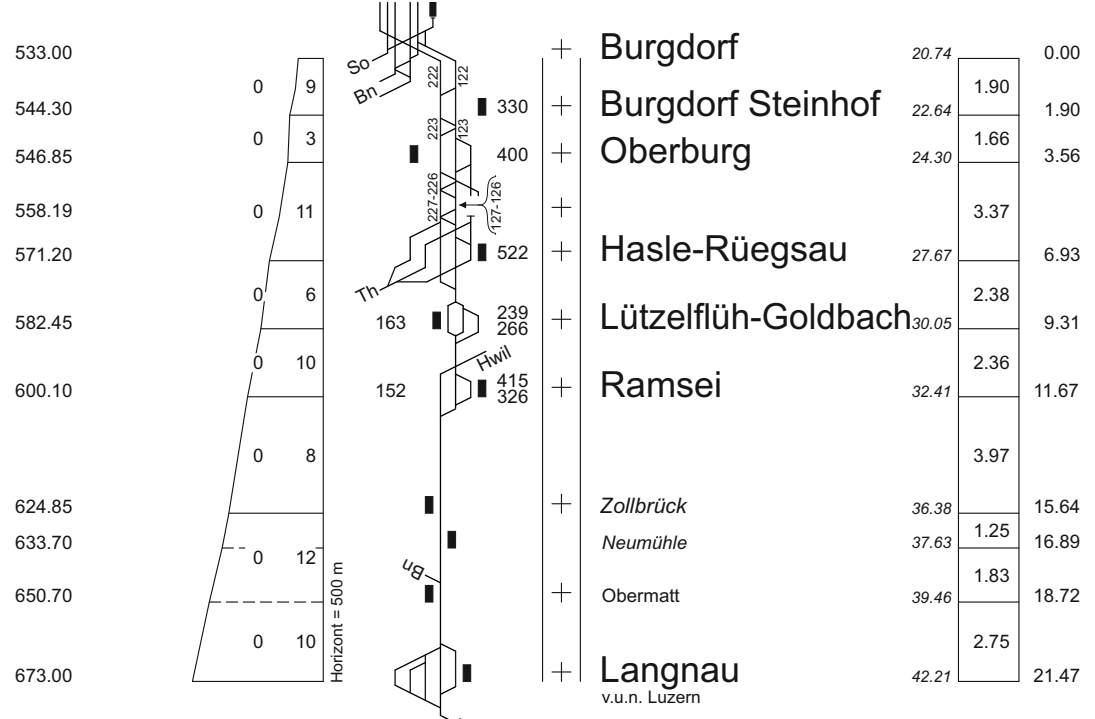

Höhen über Meer
RPN = 373.60

Längenprofil
Grösstes Gefälle
Grösste Steigung

Stationslage
Abzweigungen
Längste Ausweiche
Gleise

Blockstationen

Entf. von Stat. zu Stat.
Kilometrierung der Bahn

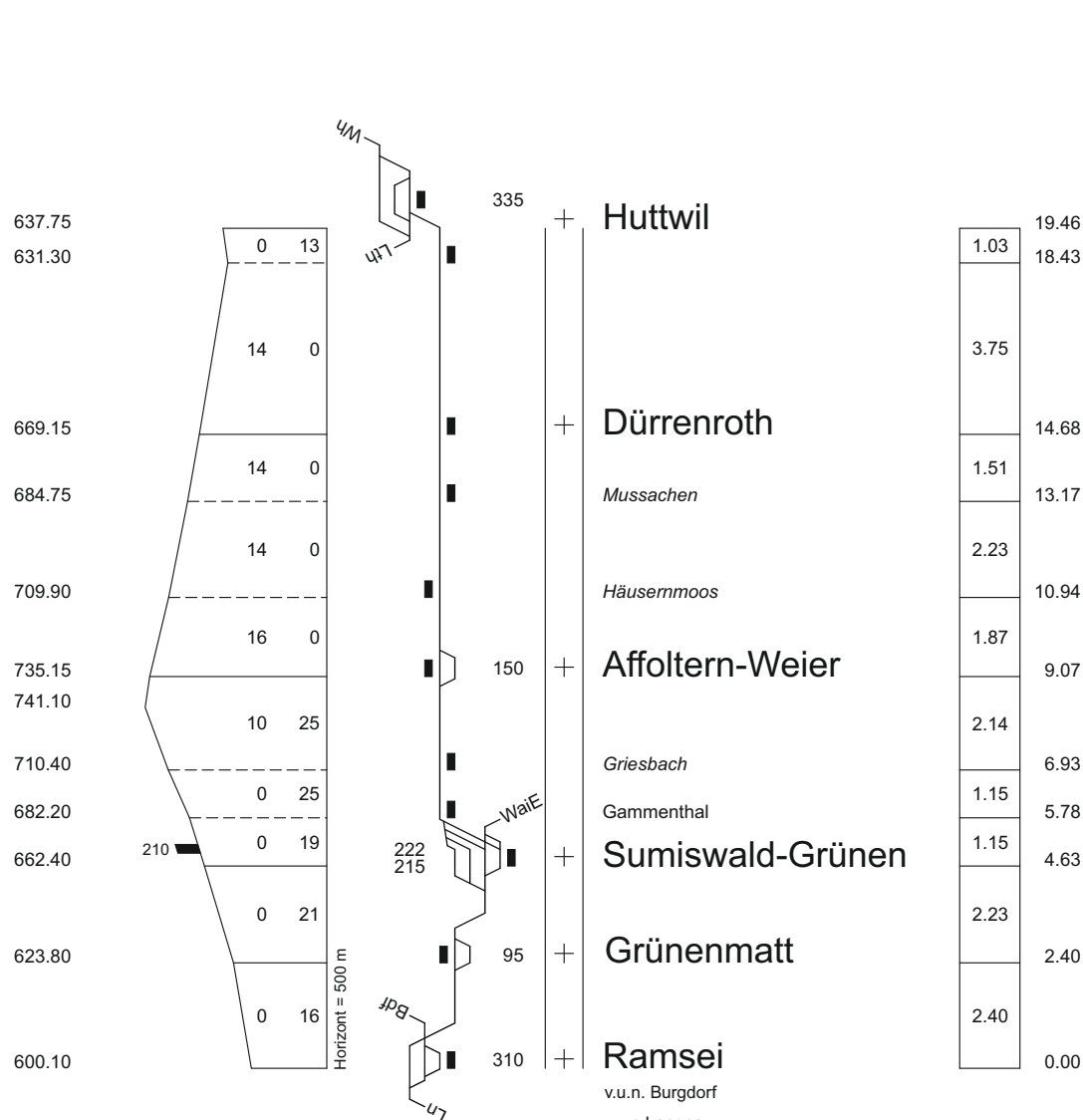
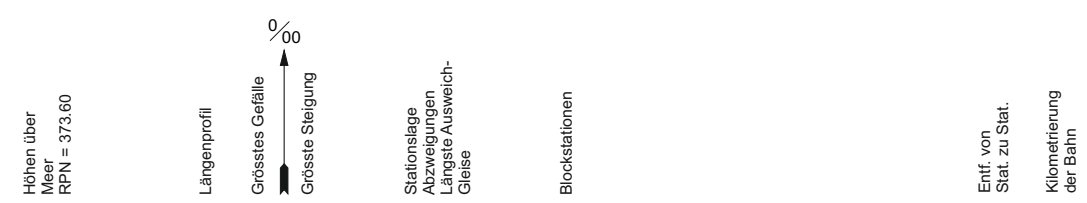
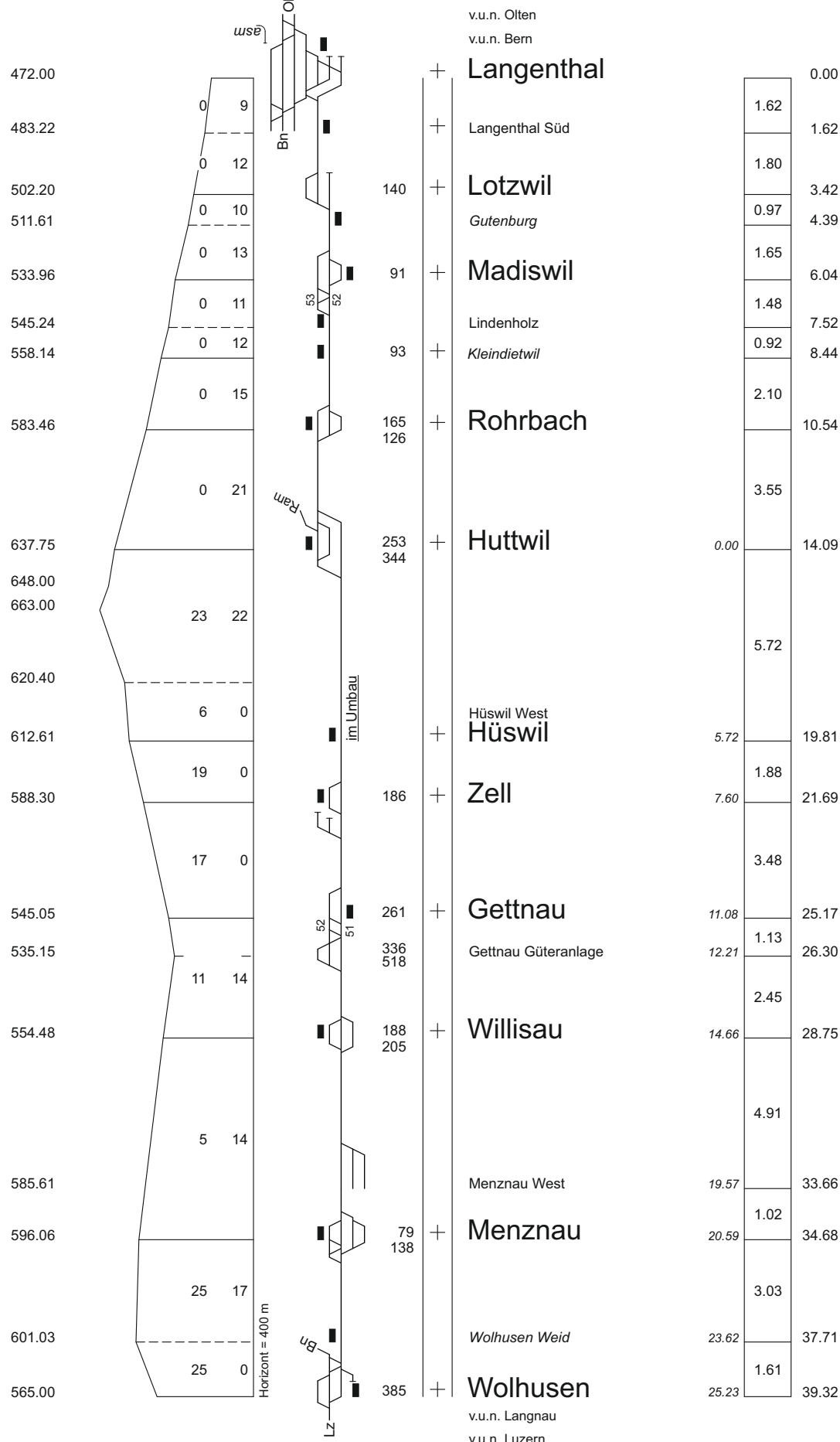

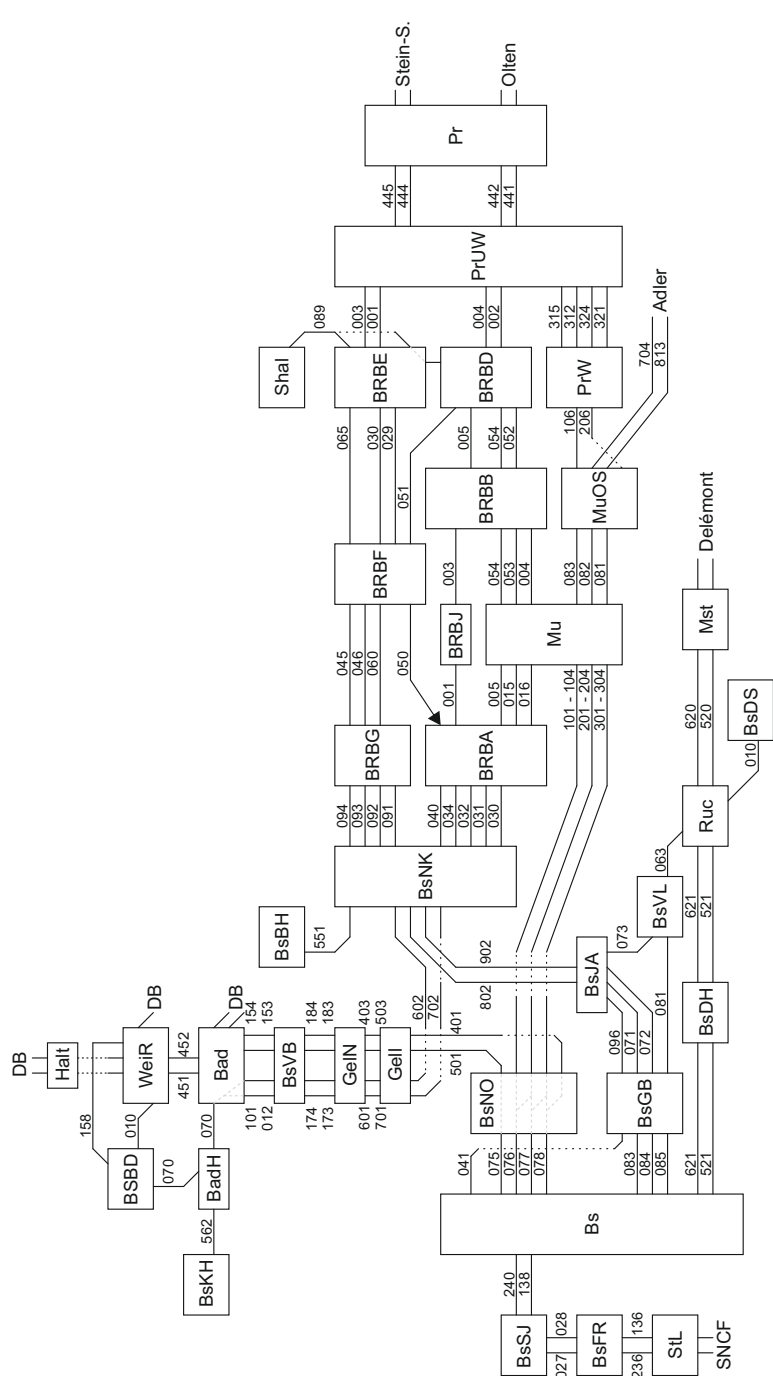

v. u. n. Olten

+ Pratteln

v. u. n. Schweizerhalle

+ Basel RB Gr E

+ Basel RB Gr F
v. u. n Gr A

+ Basel RB Gr G

Nordkopf

+ Gellert

Gellert Nord (Abzw)

+ Basel Bad. Bf.

+ Weil (Rhein)

+ Basel Bad. Rbf.

+ Basel Bad. Bf.

+ Basel Bad Rbf Kleinh. Abzw.

+ Basel Bad. Rbf.

+ Basel Bad. Bf.

+ Basel Bad Rbf Kleinh. Abzw.

+ Basel Kleinh. Hafen

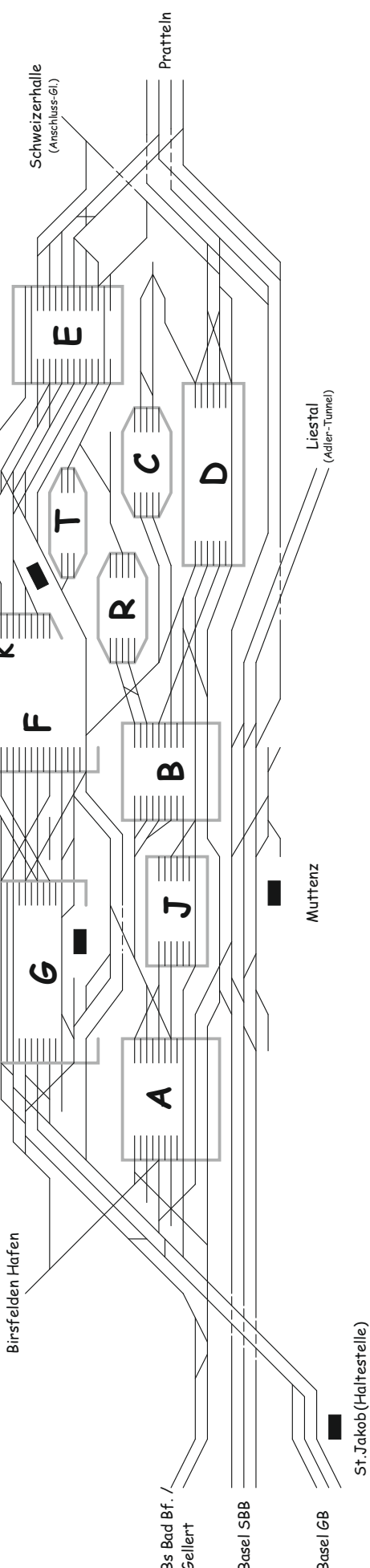

v. u. n. Stein-S.

+ Pratteln

+ Basel RB Gr D

Basel RB Gr B

+ Muttenz

+ Basel RB Gr A

Nordkopf

Basel St. Jakob

+ Basel SBB GB
v. u. n. Basel SBB (GI 041)

+ Basel SBB PB

+ Basel St. Johann

+ Saint-Louis

+ Basel RB Gr A

v. u. n. Gr G

Nordkopf

+ Birsfelden Hafen

Ausgabe von 11.12.2016

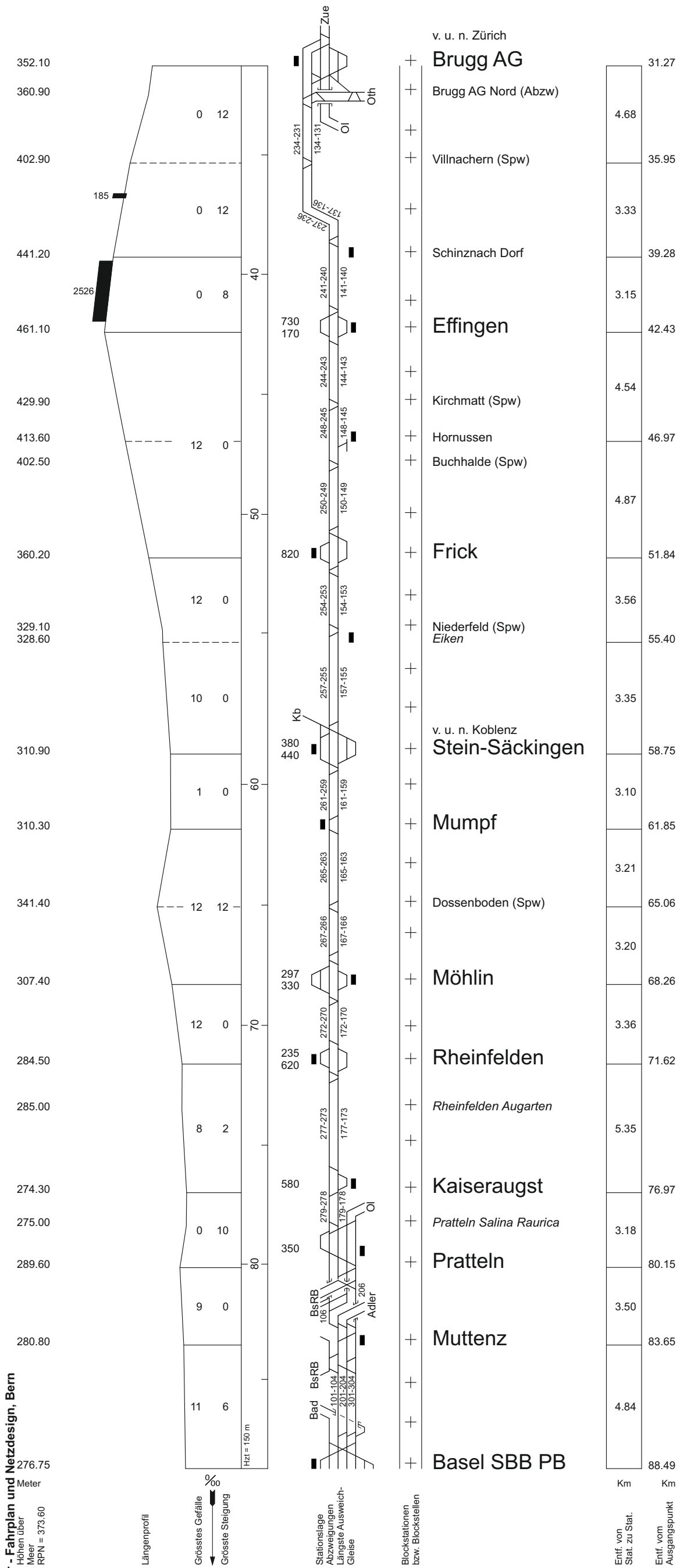

© Infrastruktur - Fahrplan und Netzdesign, Bern
 Höhen über Meer
 RPN = 373.60

Längenprofil
 Grösstes Gefälle
 Grösste Steigung

Stationslage
 Abzweigungen
 Längste Ausweiche-
 Gleise

Blockstationen
 bzw. Blockstellen

Entf. von Stat. zu Stat. Km
 Entf. vom Ausgangspunkt Km

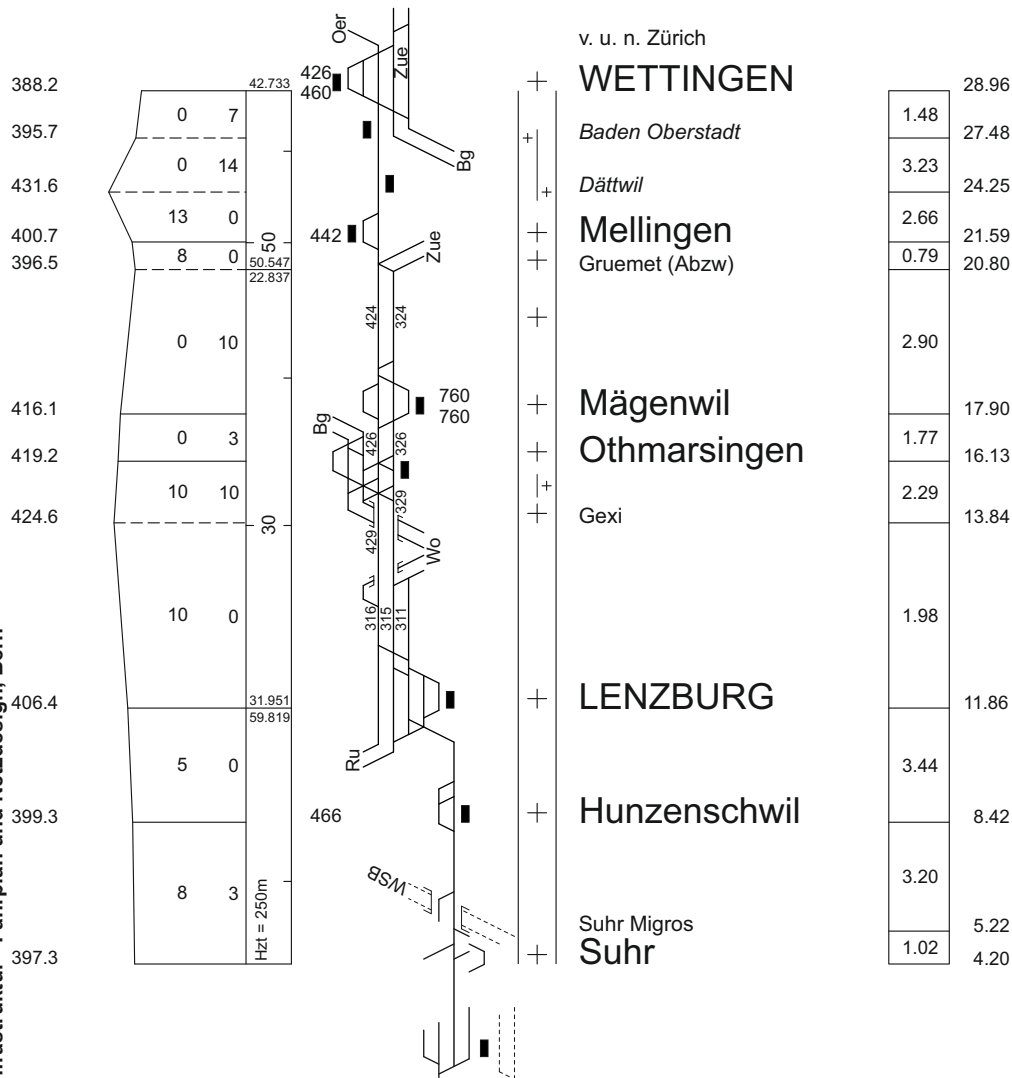
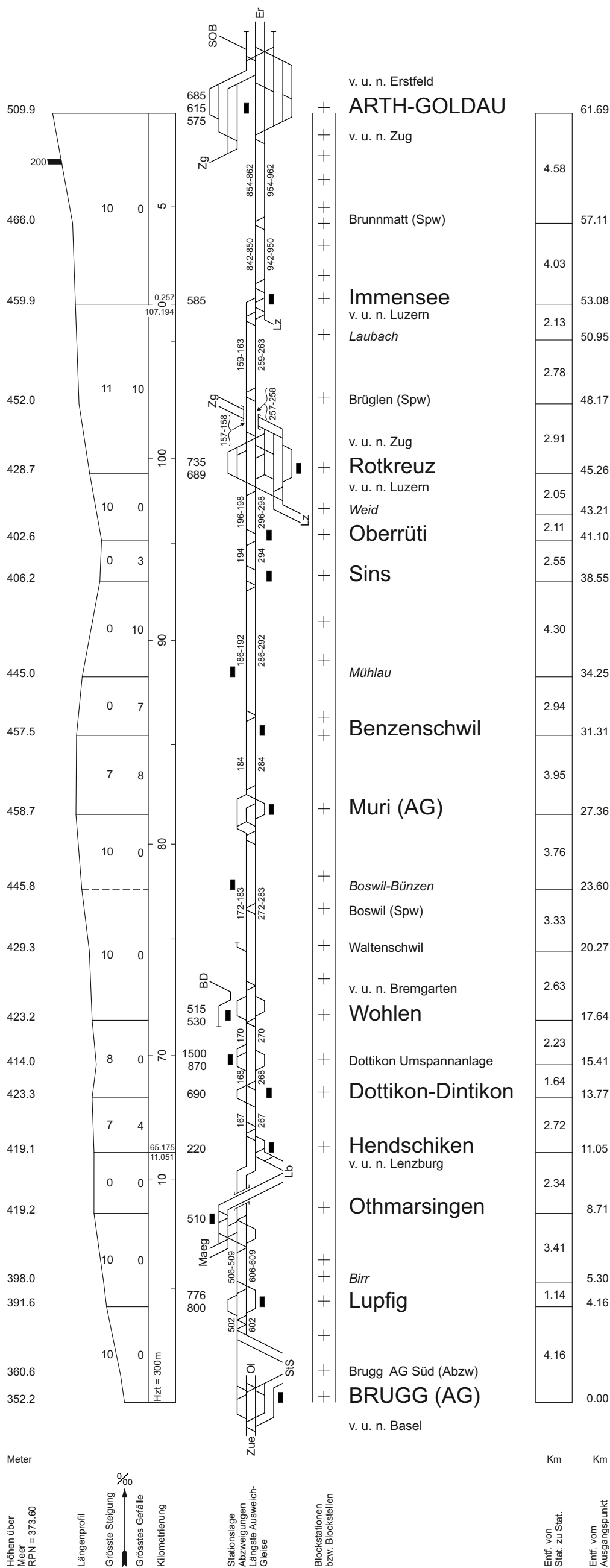

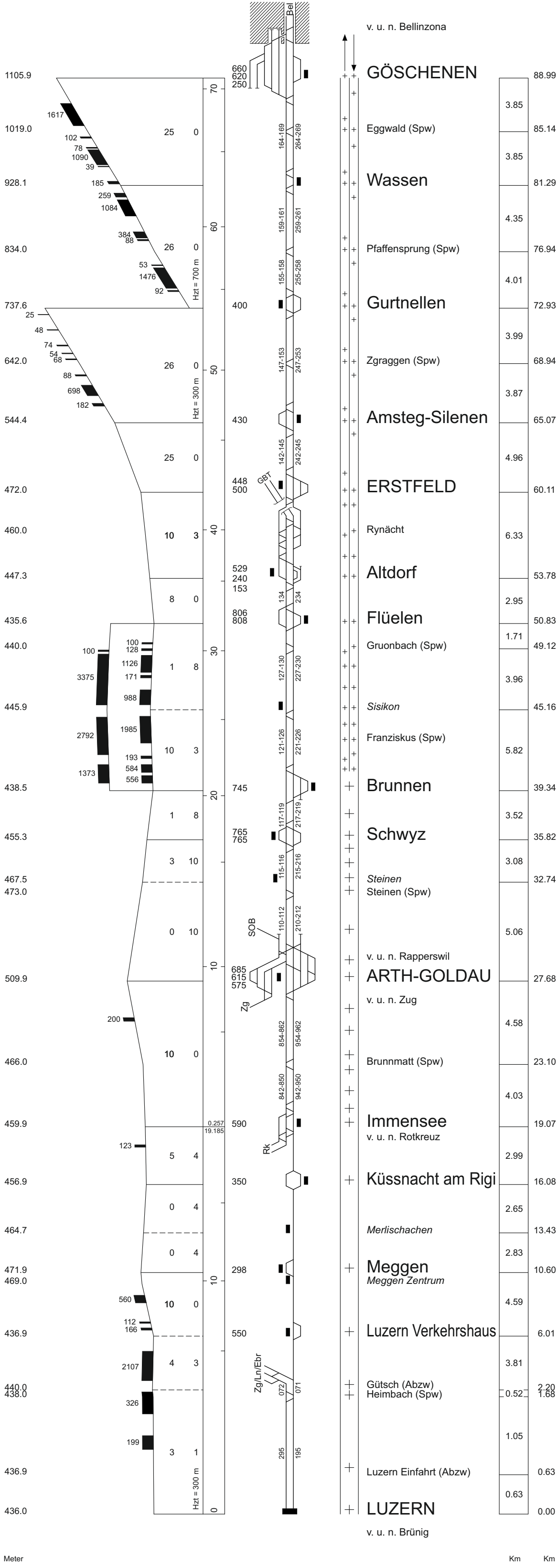

© Infrastruktur - Fahrplan und Netzdesign, Bern
 Höhen über Meer
 RPN = 373.60

Längenprofil
 Grösstes Gefälle
 Grösste Steigung
 Kilometrierung

Stationenlage
 Abzweigungen
 Längste Ausweichgleise

Blockstationen bzw. Blockstellen

Entf. von Stat. zu Stat.
 Entf. vom Ausgangspunkt

Meter

Km Km

‰

v. u. n. Bellinzona

v. u. n. Brünig

GÖSCHENEN	88.99
Eggwald (Spw)	3.85
85.14	
3.85	
Wassen	81.29
4.35	
Pfaffensprung (Spw)	76.94
4.01	
Gurtellen	72.93
3.99	
Zraggen (Spw)	68.94
3.87	
Amsteg-Silenen	65.07
4.96	
ERSTFELD	60.11
Rynächt	6.33
Altdorf	53.78
2.95	
Flüelen	50.83
Gruonbach (Spw)	1.71
49.12	
3.96	
Sisikon	45.16
Franziskus (Spw)	5.82
Brunnen	39.34
3.52	
Schwyz	35.82
3.08	
Steinen	32.74
Steinen (Spw)	5.06
ARTH-GOLDAU	27.68
v. u. n. Zug	4.58
Brunnmatt (Spw)	23.10
4.03	
Immensee	19.07
v. u. n. Rotkreuz	2.99
Küssnacht am Rigi	16.08
2.65	
Merlischachen	13.43
2.83	
Meggen	10.60
Meggen Zentrum	4.59
Luzern Verkehrshaus	6.01
3.81	
Gütsch (Abzw)	2.20
Heimbach (Spw)	1.68
1.05	
Luzern Einfahrt (Abzw)	0.63
LUZERN	0.00

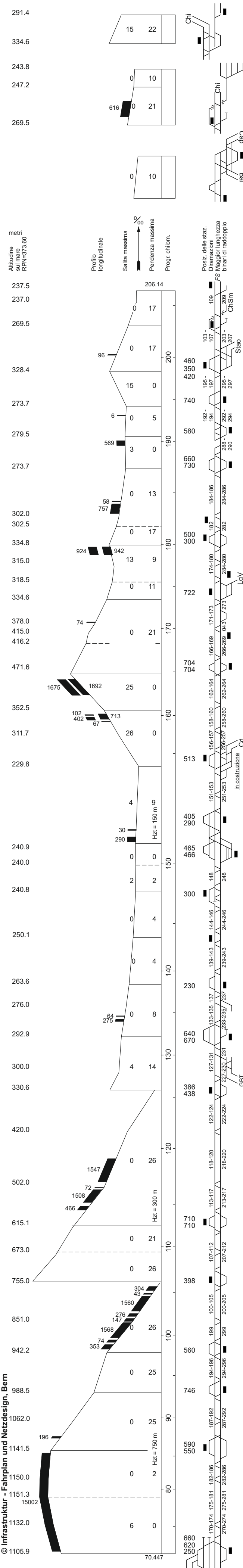

Stazione	Dist. fra le stazioni (Km)	Dist. dal punto di origine (Km)
Lugano Vedeggio	107.34	
Taverne-Torricella	3.79	103.55
Chiasso SM	1.05	135.61
Balerna	1.50	134.56
Mendrisio	3.6	133.06
Stabio	3.6	0.0
Chiasso	2.61	135.67
Balerna	4.82	133.06
Mendrisio	4.10	128.24
Mendrisio S. Martino	4.10	124.14
Capolago-R.S.V.	3.58	120.56
Maroggia-Melano	3.81	116.75
Bissone	4.01	112.74
Melide	2.39	109.98
Lugano Paradiso (c bin) Lugano Paradiso	0.37	107.40
Lugano	2.58	105.63
Lamone (c bin)	1.77	103.55
Lamone-Cadempino da e per Lugano Vedeggio	2.08	100.85
Taverne-Torricella	2.70	99.55
Sigirino	1.30	98.38
Mezzovico (c bin) Mezzovico	1.17	94.74
Rivera-Bironico	3.64	90.92
Al Motto (c bin)	3.82	87.57
Vigana (c bin) da e per Luino/Locarno	3.35	80.42
Giubiasco	4.00	79.29
Bellinzona Sud	3.15	76.79
Bellinzona	1.13	73.00
Bellinzona Collegamento	2.50	67.49
S. Paolo	3.79	61.32
Bellinzona Nord (bif)	5.51	55.03
Castione-Arbedo	6.17	50.66
Claro	6.29	46.96
Osogna-Cresciano	4.37	42.12
Giustizia (dira)	3.70	38.93
Biasca	4.84	35.57
Pollegio Nord	4.10	31.47
Bodio	4.10	27.37
Giornico (c bin)	4.79	22.58
Pianotondo (c bin)	3.37	19.21
Lavorgo	3.47	15.74
Chiggiona (c bin)	4.89	10.85
Faido	5.95	4.90
Pardorea (c bin)	4.90	0.00
Rodi-Fiesso		
Ambri-Piotta		
Sordo (c bin)		
Airolo		
Gottardo Sud (c bin)		
Gotthard Nord (Spw)		
Göschenen		

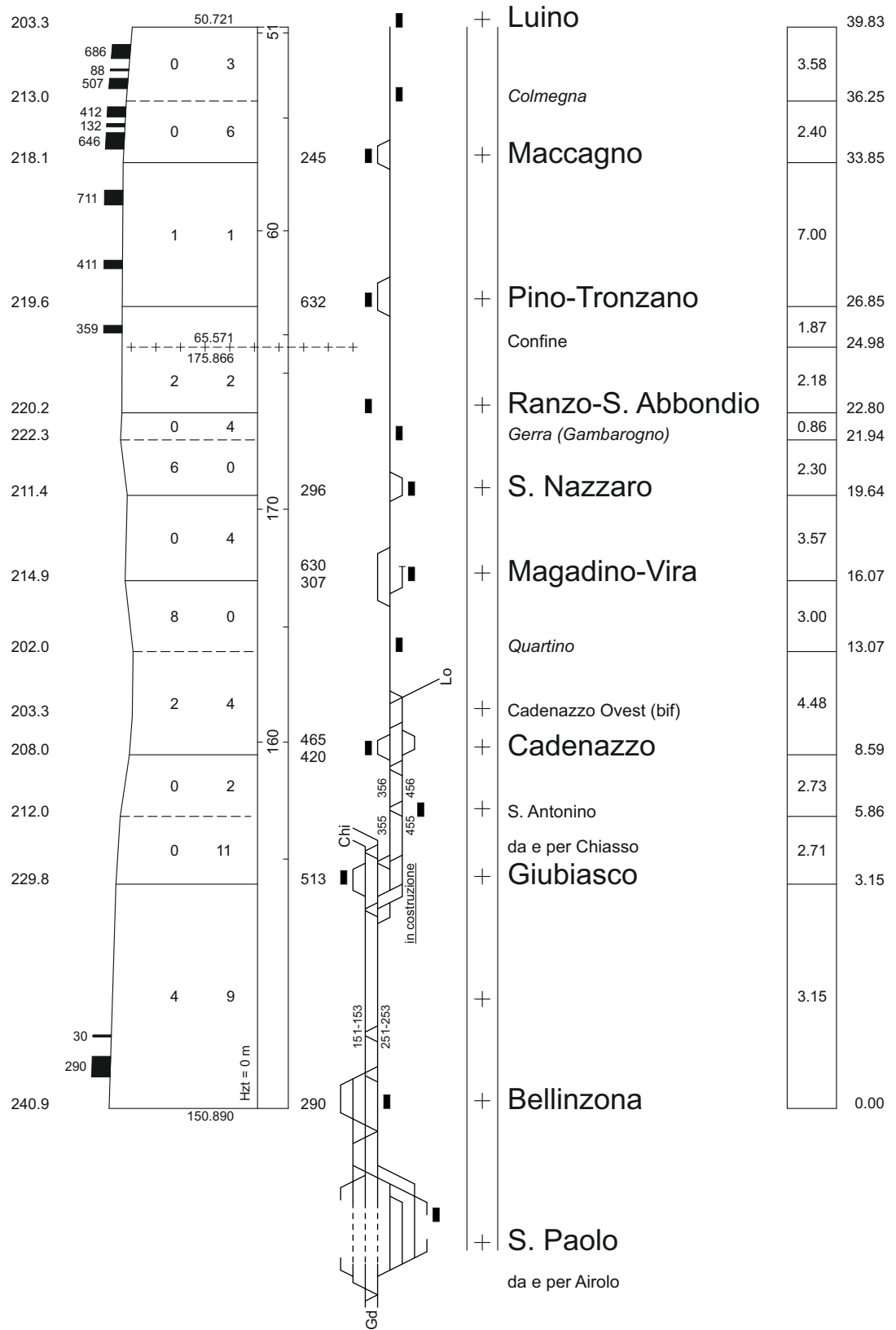
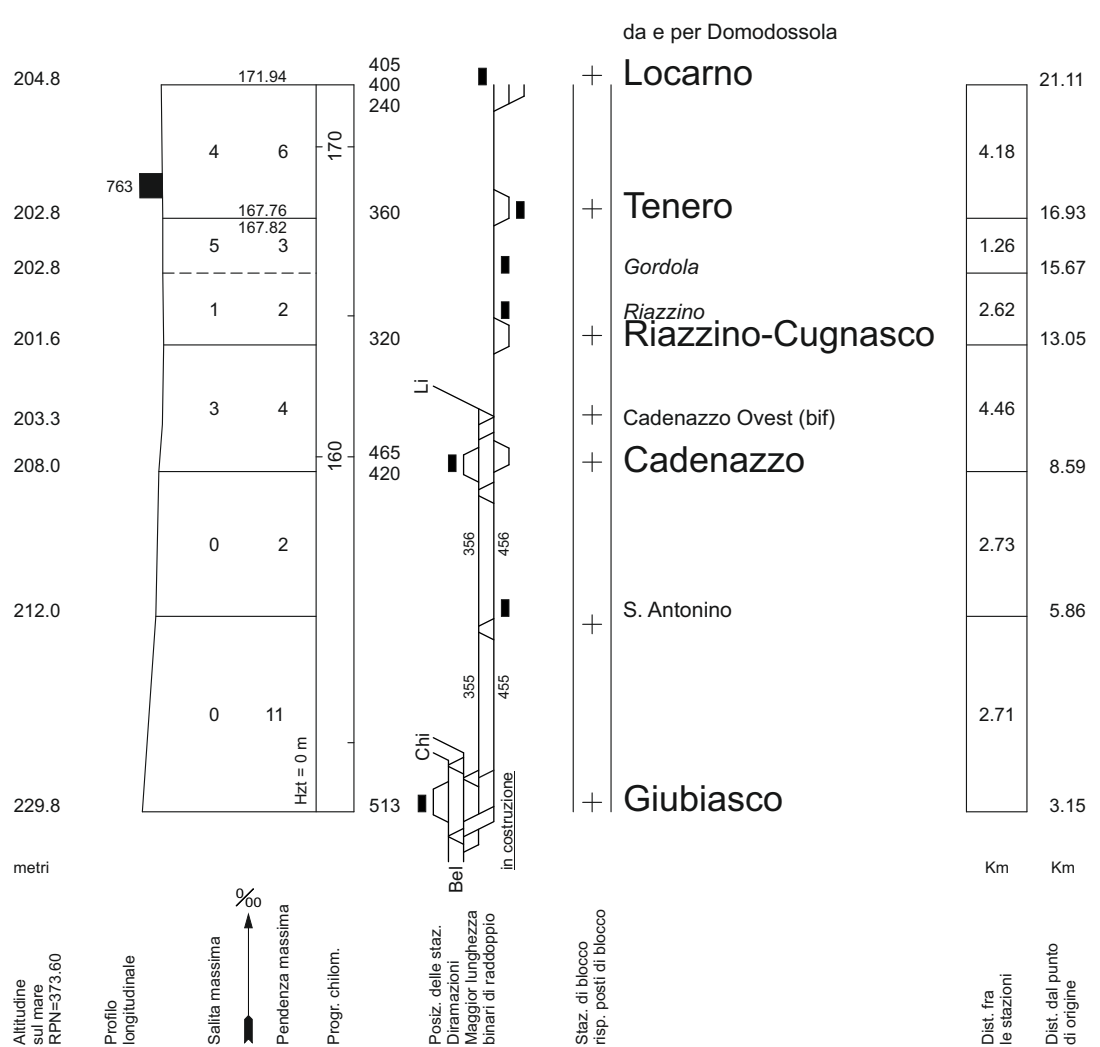



SBB 61

I-FN-FPA-ROT

Ausgabe von 11.12.2016

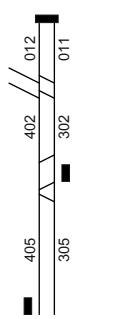
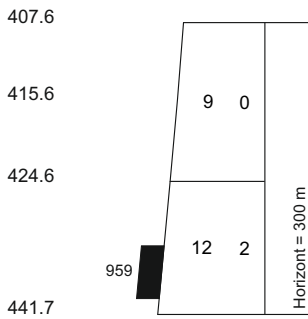

+	Zürich PB A 3-18	0.00
+	Z Viadukt (Abzw)	1.40
+	Z Wipkingen	1.49
+	Z Birchsteg (Abzw)	1.80
+	Z Oerlikon	0.62
		4.69
		5.31

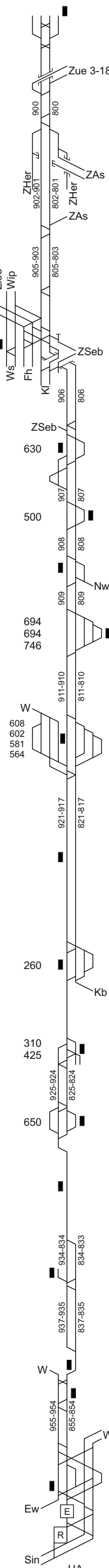
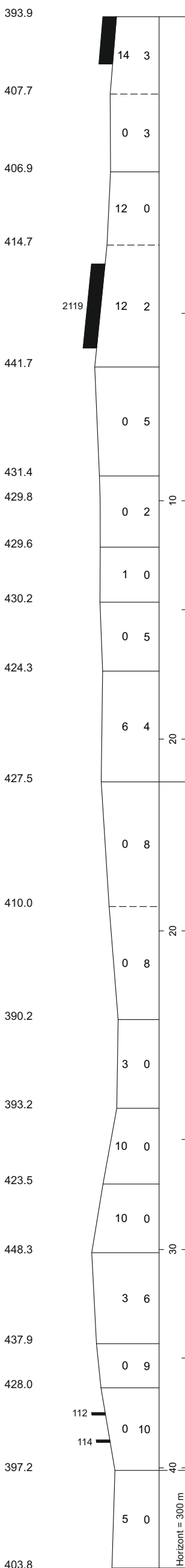

+	Zürich PB S21-24	0.00
+	Z Langstrasse	1.92
+	Z Hardbrücke v/n Altstetten	1.35
+	v/n Altstetten Hard Käferberg (Abzw)	3.27
+		3.08
+	Z Birchsteg (Abzw) Z Oerlikon	6.35
+	v/n Seebach	2.49
+	Glattbrugg Tankanlage Rümliang	8.84
+		3.34
+	Rümliang	12.18
+		2.59
+	Oberglatt v/n Niederweningen	14.77
+		2.12
+	Niederglatt	16.89
+		5.06
+	v/n Winterthur	21.95
+	Bülach	3.14
+		25.09
+	Glattfelden	2.85
+		27.94
+	Eglisau v/n Koblenz	1.35
+		29.29
+	Hüntwangen-Wil	3.44
+		32.73
+	Rafz	3.12
+		35.85
+	Lottstetten	2.34
+		38.19
+	Jestetten Süd (Verzw)	1.83
+	Jestetten	40.02
+		3.57
+	Fischerhölzli (Verzw)	43.59
+	Neuhausen Rheinfall v/n Winterthur	1.08
+	Neuhausen	44.67
+		1.14
+		45.81
+		2.23
+	Schaffhausen	48.04
+	Schaffhausen GB	

Höhe über Meer RPN=373.60
 Längenprofil
 Grösstes Gefälle
 Grösste Steigung
 Kilometrierung

Stationsanlage
 Abzweigungen
 Längste Ausweichgleise

Blockstationen
 Entfernung von Stat. zu Stat.
 Entfernung vom Ausgangspunkt

© Infrastruktur - Fahrplan und Netzdesign, Bern

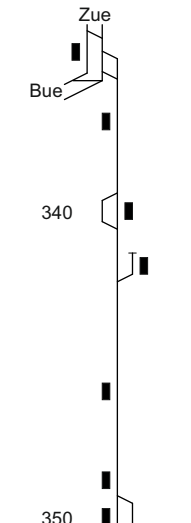
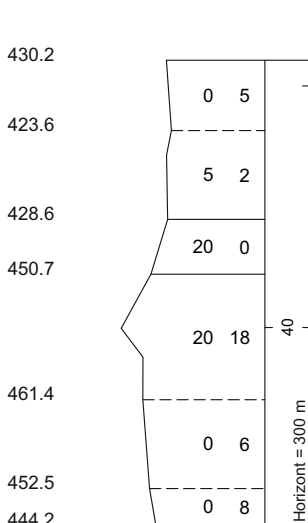

+	Oberglatt	0.00
+	Niederhasli	1.92
+		2.40
+	Dielsdorf	4.32
+	Steinmaur	1.33
+		5.65
+		2.86
+	Schöffliisdorf-Oberweningen	8.51
+		2.47
+	N'weningen Dorf	10.98
+	Niederweningen	1.06
		12.04



SBB

63 A

I-FN-FPA-ROT

Ausgabe von 11.12.2016

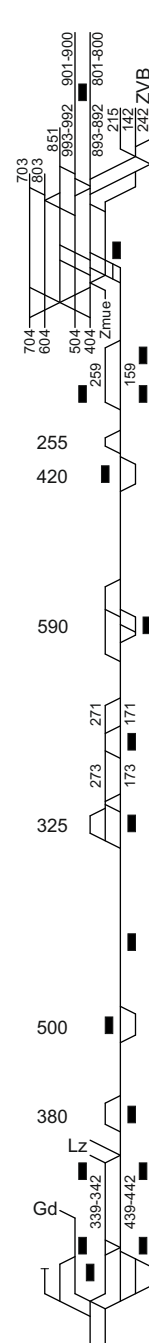
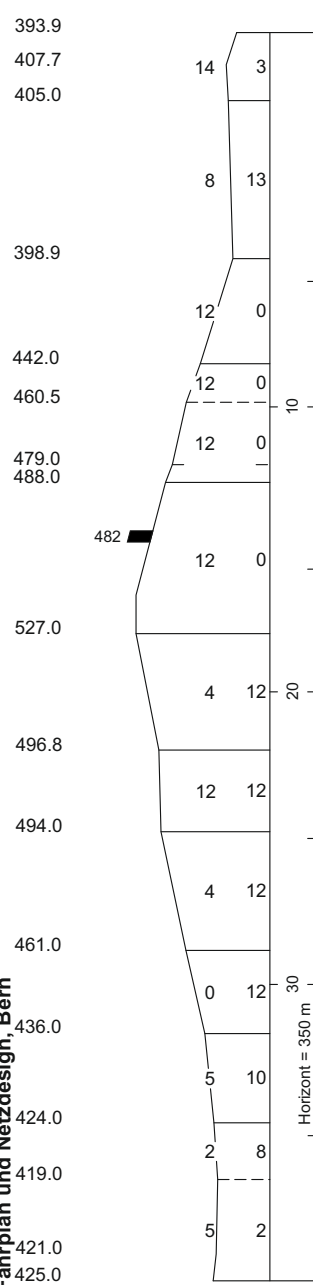

+	Zürich PB S21-24	0.00
+	Z Langstrasse	1.90
+	Z Hardbrücke	1.90
+		2.20
+	Z Altstetten	4.10
+	Urdorf	8.51
+	Urdorf Weihermatt	1.33
+	Mören (Verzw)	2.17
+	Birmensdorf Industrie	0.64
+	Birmensdorf ZH	12.01
+		12.65
+		4.64
+	Bonstetten Nord (Verzw)	17.29
+	Bonstetten-W.	0.70
+	Bonstetten Süd (Verzw)	0.96
+		17.99
+		18.95
+		1.86
+	Hedingen Nord (Verzw)	20.81
+	Hedingen	1.23
+		22.04
+		2.73
+	Affoltern am Albis	24.77
+		4.07
+	Mettmenstetten	28.84
+		2.82
+	Knonau	31.66
+		3.00
+	Steinhausen	34.66
+	v/n Luzern	1.63
+	Kollermühle (Abzw)	0.23
+	Zug Chollermüli	36.29
+		36.52
+		1.72
+	v/n Goldau	38.24
+	Zug Schutzengel	0.65
+	Zug	38.89

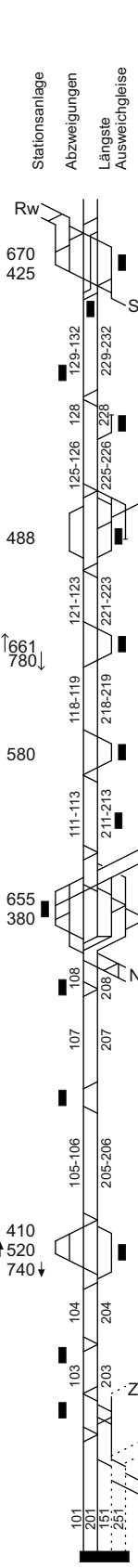
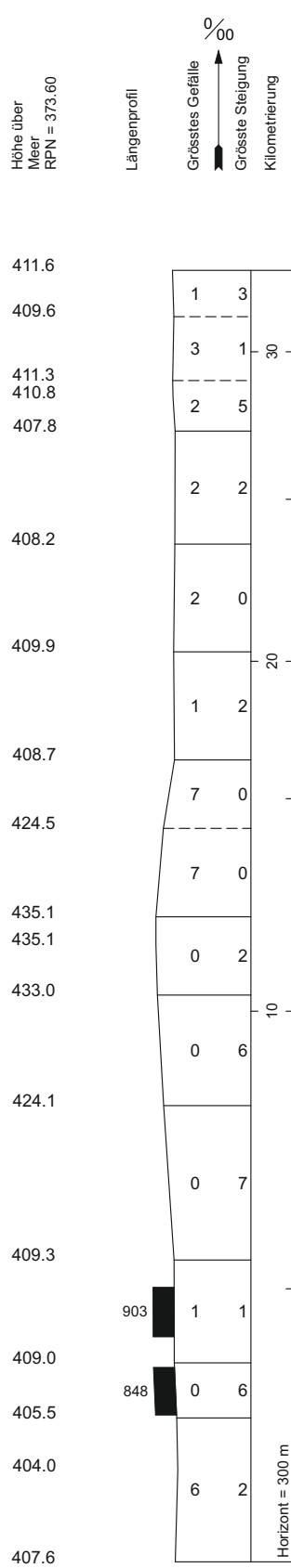

+	Altendorf	
+	v/n Ziegelbrücke	
+	Pfäffikon SZ	33.08
+	Freienbach SBB	1.73
+		31.35
+		2.34
+	Bäch	0.64
+	Hafen Bäch (Spw)	29.01
+	Richterswil	1.27
+		28.37
+		27.10
+		3.48
+	v/n Samstagern	
+	Wädenswil	23.62
+		3.26
+	Au ZH	20.36
+		3.93
+	Horgen	16.43
+		2.54
+	Oberrieden	13.89
+	v/n Zug	
+	Thalwil	2.14
+	Thalwil Nord (Abzw)	11.75
+		1.45
+	Rüschlikon	10.30
+		2.00
+	Kilchberg	8.30
+		2.83
+	Z Wollishofen	5.47
+		1.87
+	Z Enge	3.60
+	Z Wiedikon	1.00
+		2.60
+		0.91
+	Z Aussersihl (Abzw)	1.69
+	v/n Zürich VB	
+	Zürich PB	0.00

Gl. 101/201

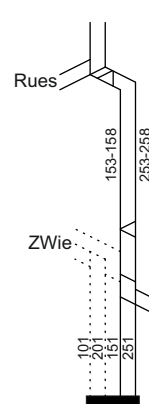

+	Thalwil Nord (Abzw)	11.67
+	Nidelbad (Abzw)	2.27
+		9.40
+		6.26
+	Z Kollerwiese	3.14
+	Z Aussersihl (Abzw)	1.45
+	v/n Zürich VB	1.69
+	Zürich PB	0.00

Gl. 151/251

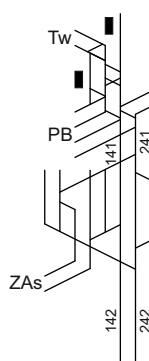

+	Z Giesshübel	1.03
+	Z Wiedikon	4.18
+	Z Aussersihl (Abzw)	2.10
+	Zürich VB	2.08
+		2.08
+	Z Altstetten	0.00



SBB 64

I-FN-FPA-ROT

Ausgabe von 11.12.2016

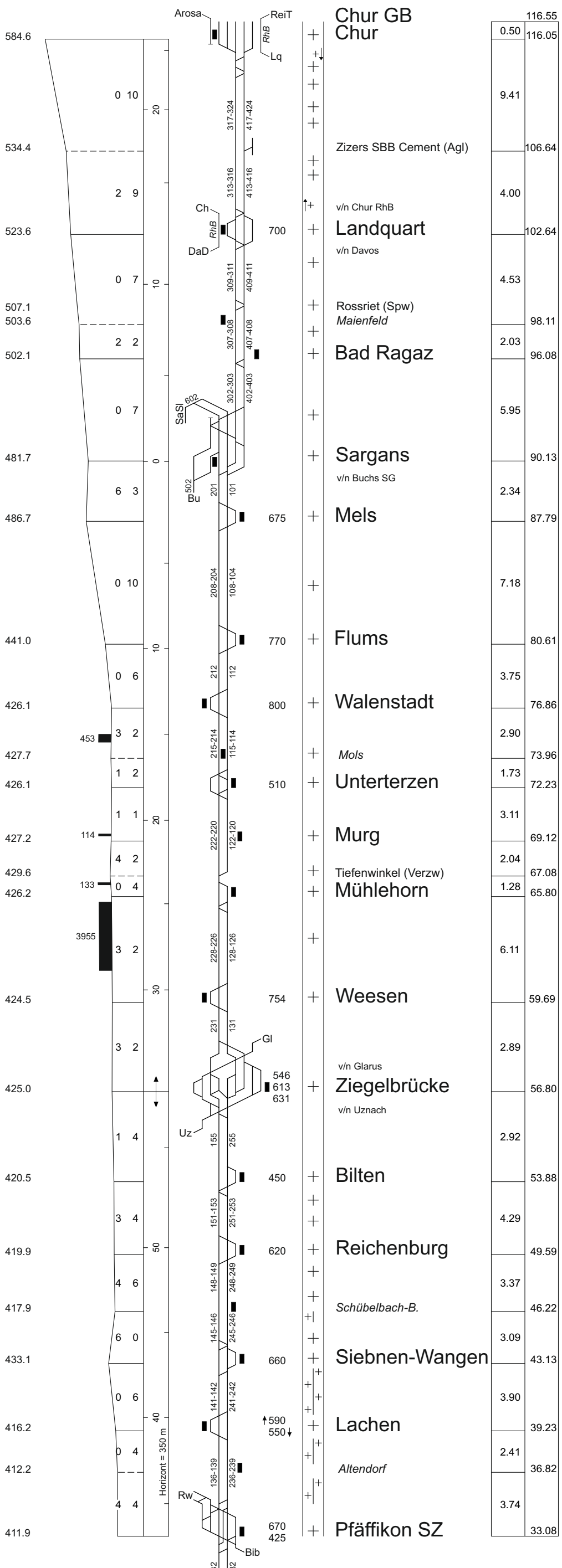
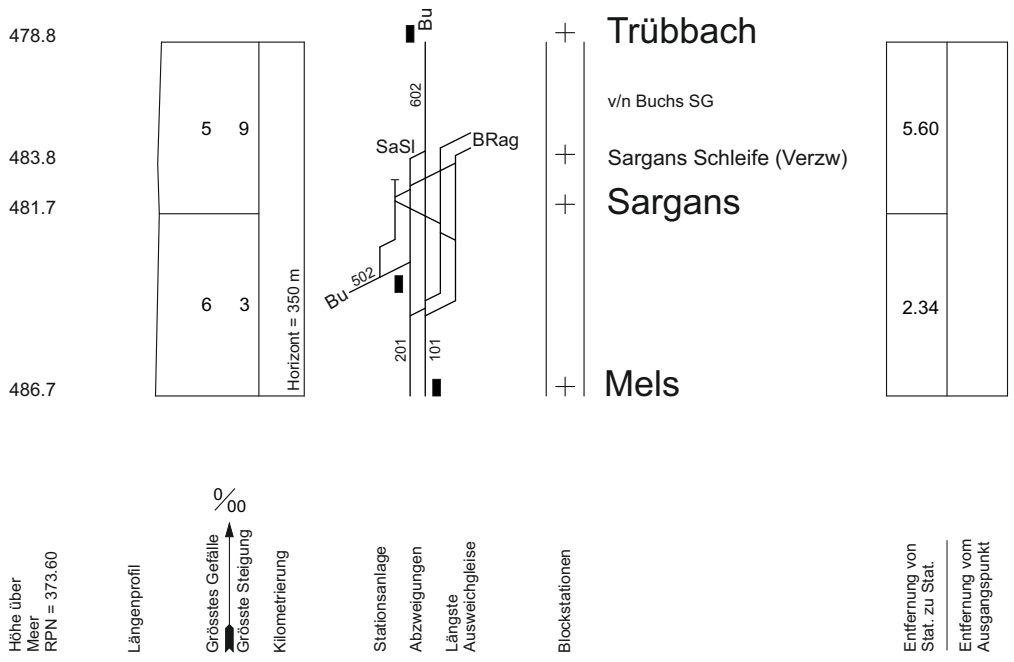



SBB 65

I-FN-FPA-ROT

Ausgabe von 11.12.2016

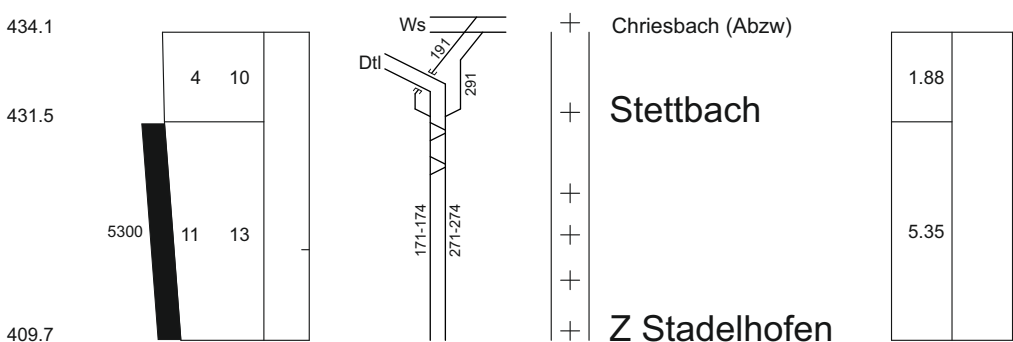
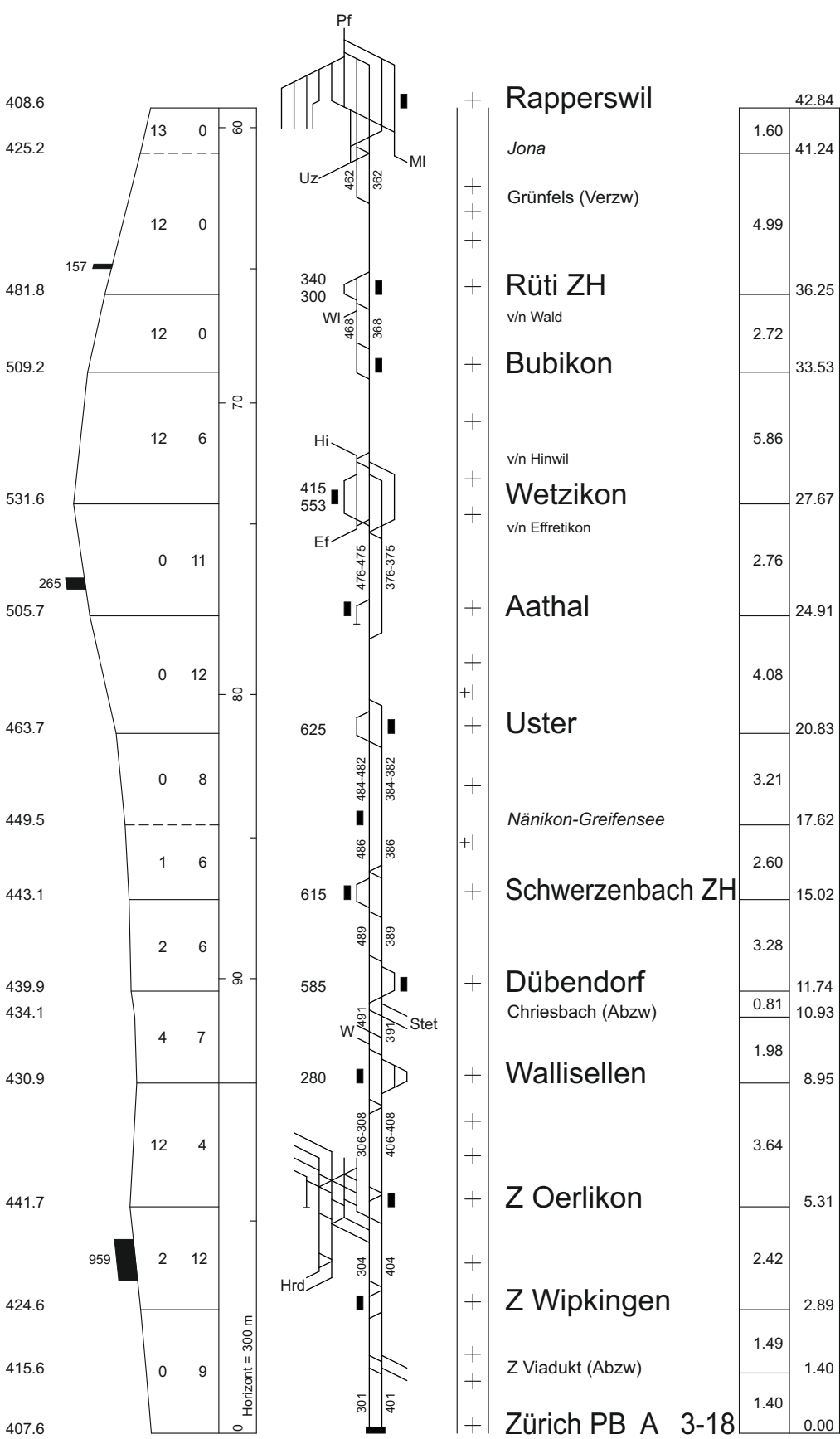

Höhe über Meer
RPN = 373.60

Langenprofil
Grösstes Gefälle
Grösste Steigung
Kilometrierung

Stationsanlage
Abzweigungen
Längste Ausweicheleise

Blockstationen

Entfernung von Stat. zu Stat.
Entfernung vom Ausgangspunkt

© Infrastruktur - Fahrplan und Netzdesign, Bern

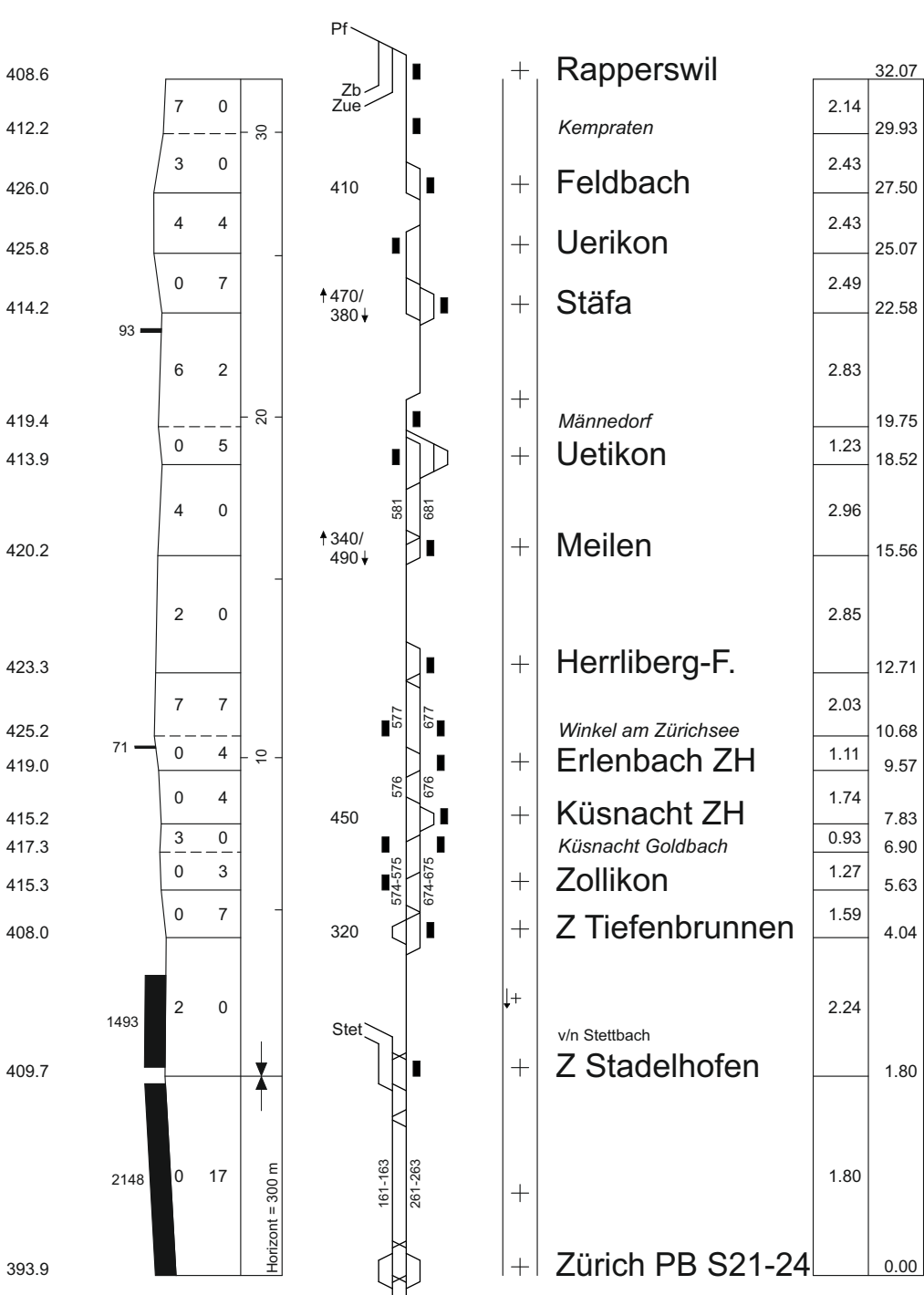



I-FN-FPA-ROT

Ausgabe von 11.12.2016

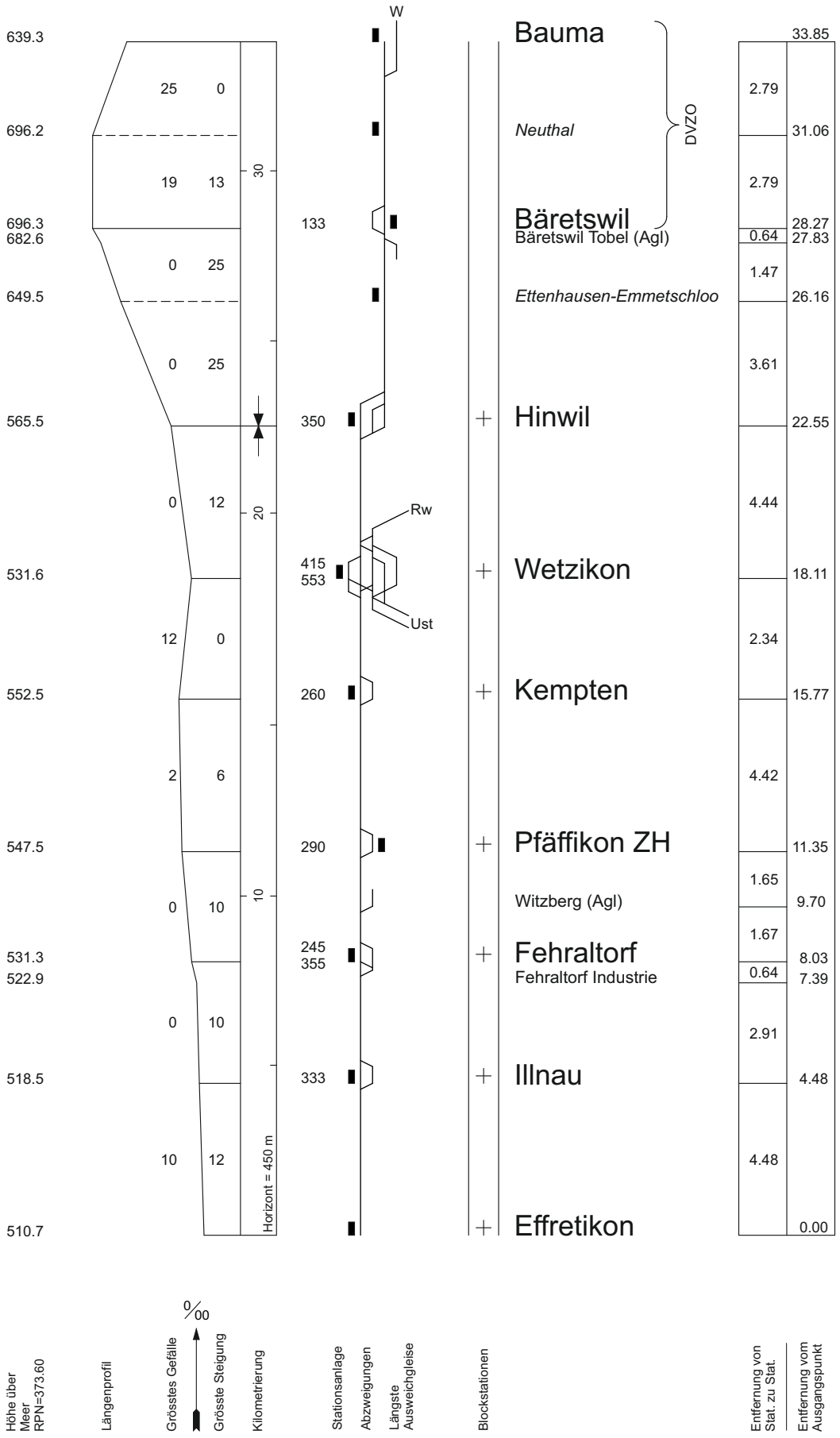

© Infrastruktur - Fahrplan und Netzdesign, Bern

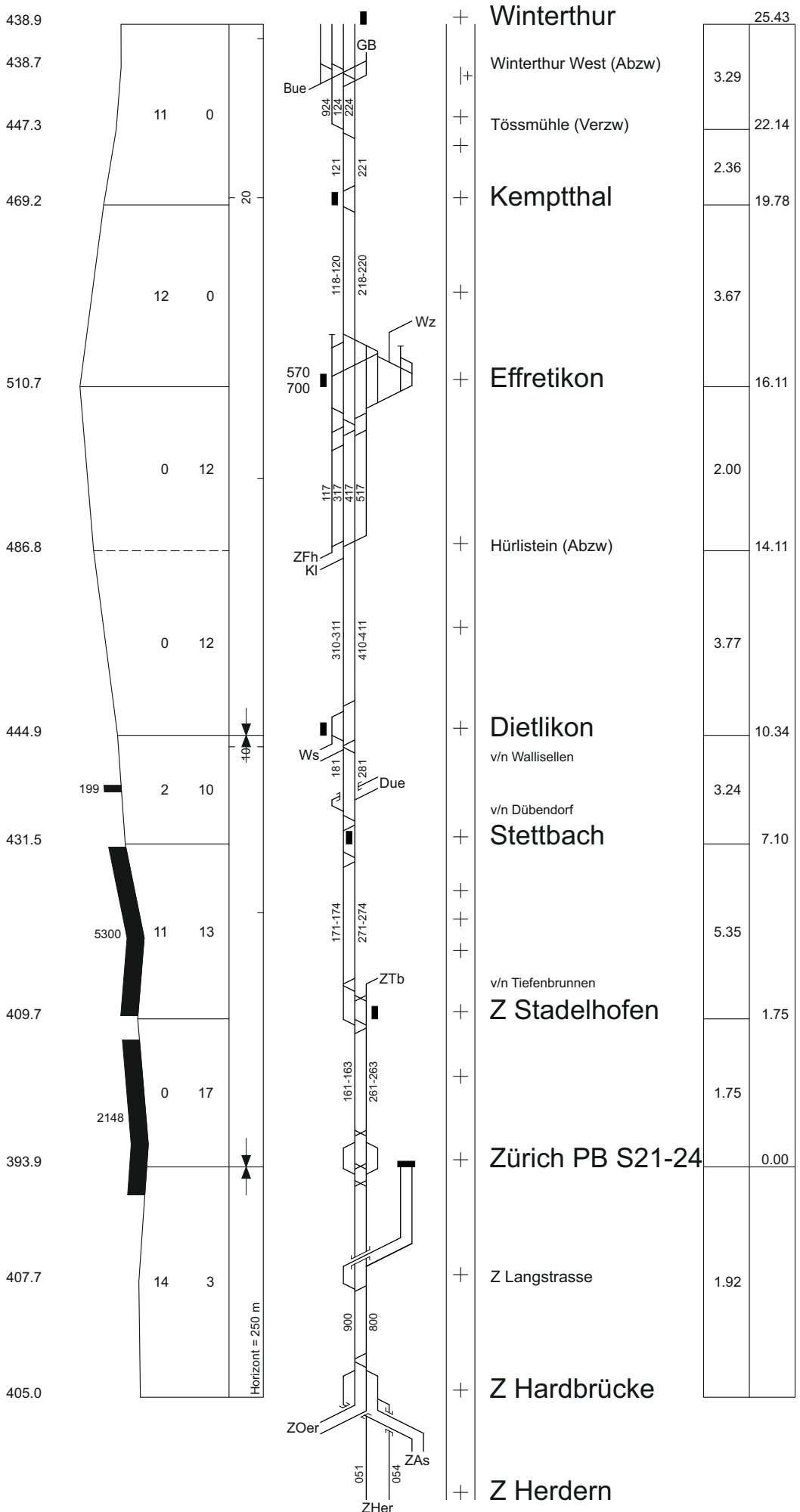



SBB 70 A

I-FN-FPA-ROT

Ausgabe von 11.12.2016

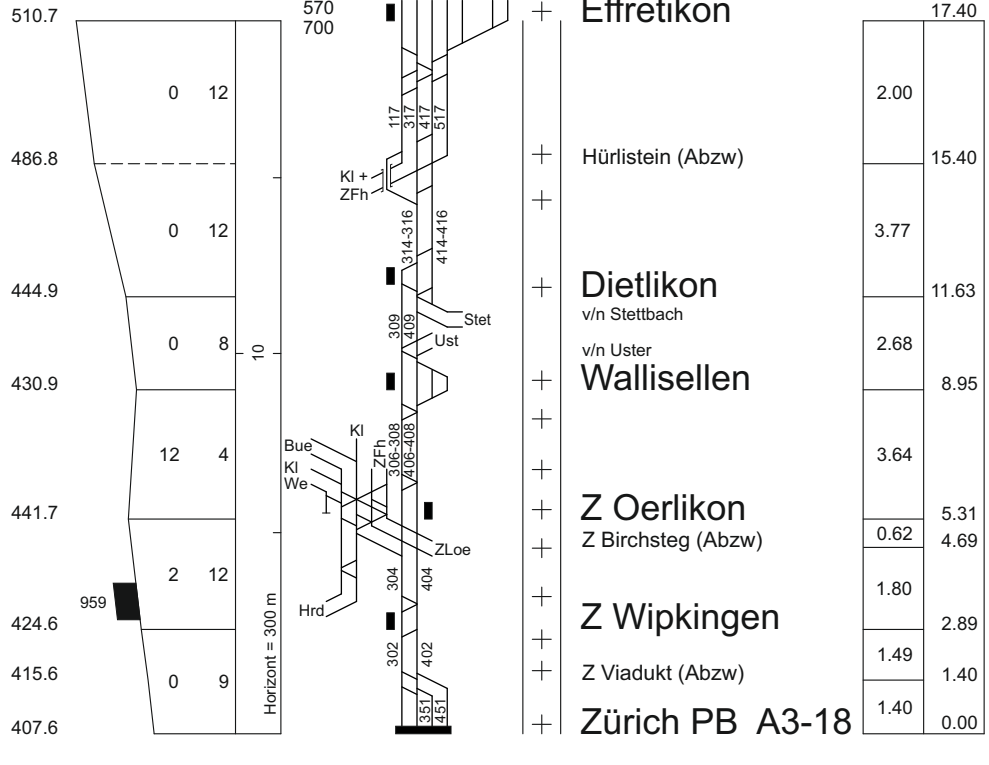
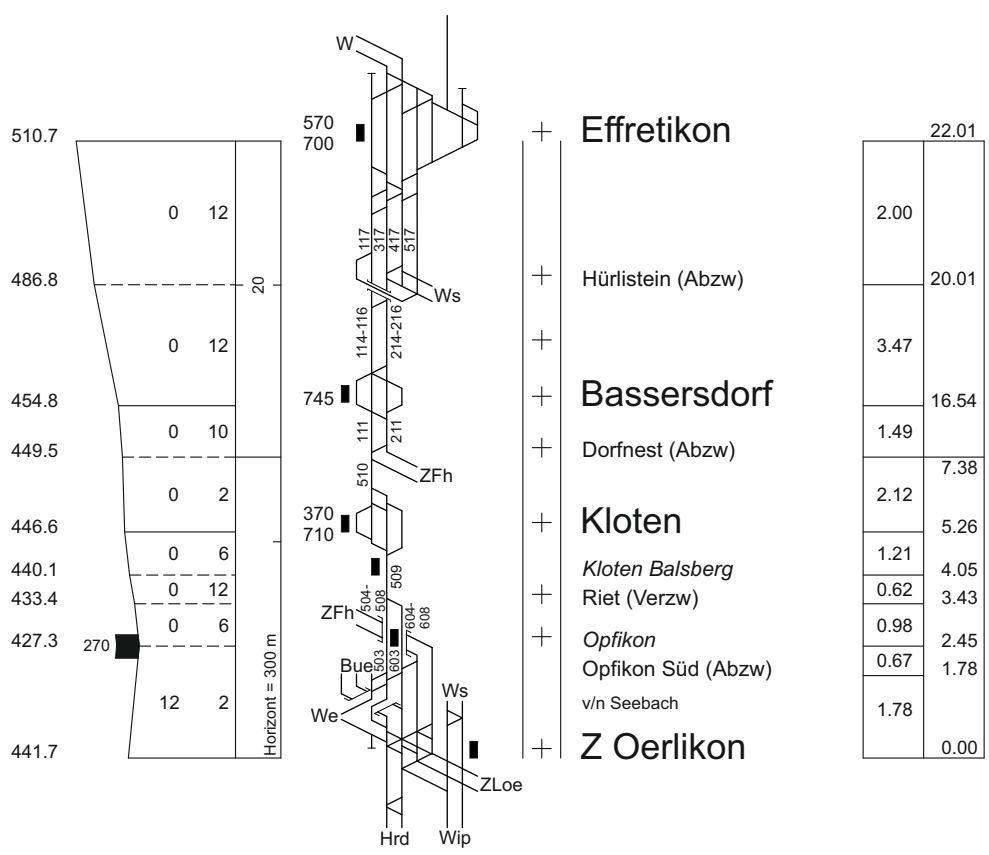
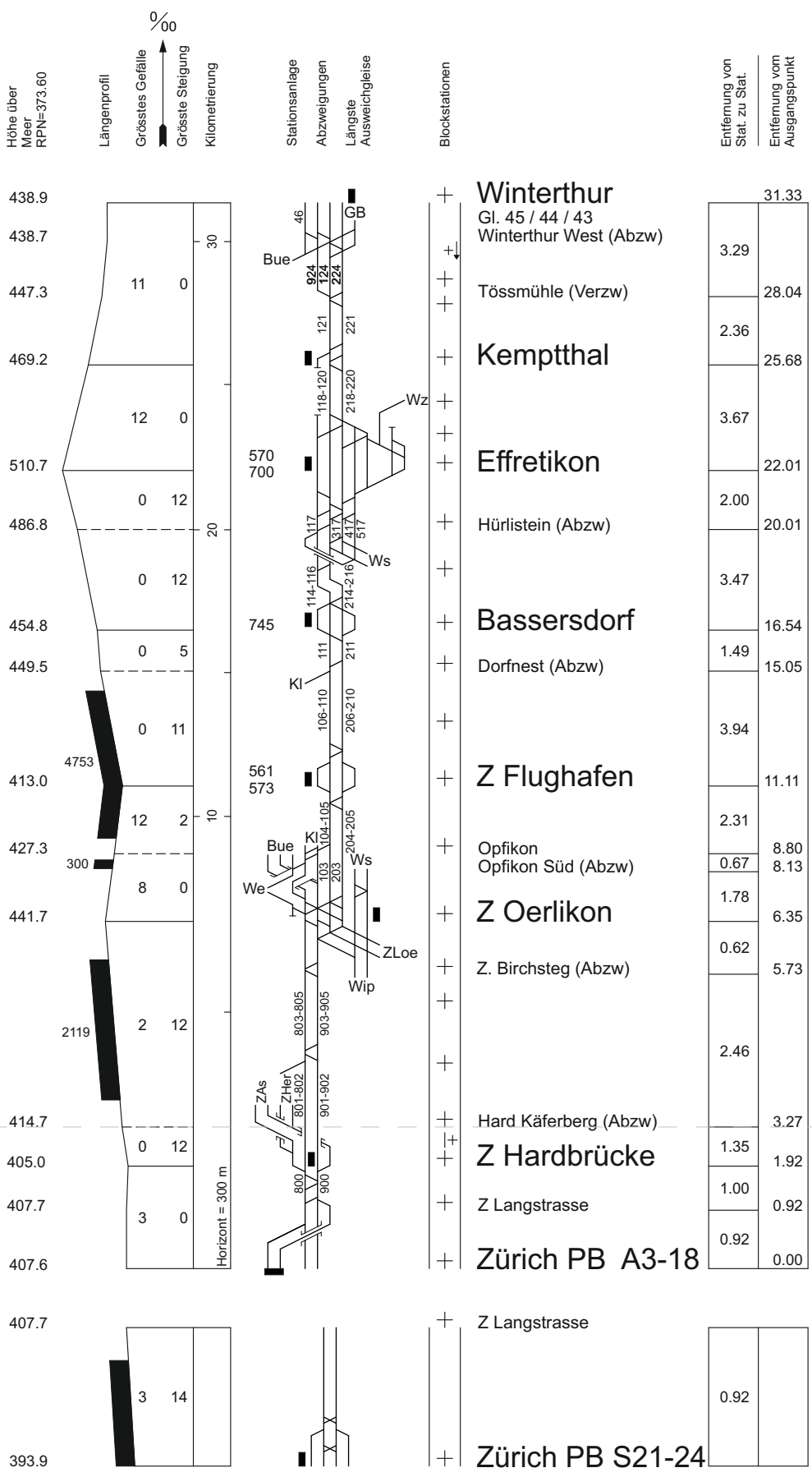



SBB 71

I-FN-FPA-ROT

Ausgabe von 11.12.2016

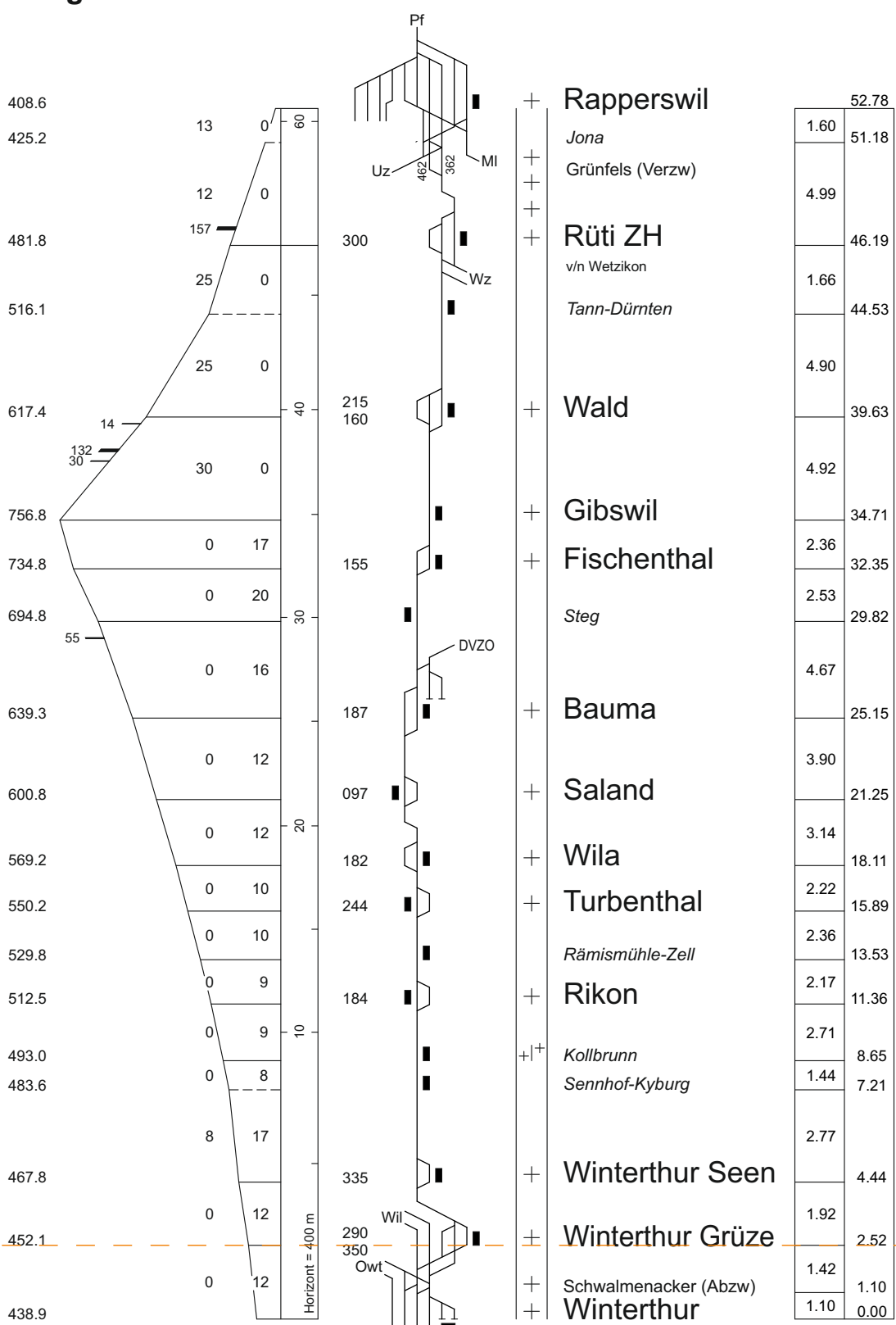

Höhe über Meer RPN=373.60
 Längenprofil
 Grösstes Gefälle
 Grösste Steigung
 Kilometrierung
 Stationsanlage
 Abzweigungen
 Längste Ausweichgleise
 Blockstationen
 Entfernung von Stat. zu Stat.
 Entfernung vom Ausgangspunkt

© Infrastruktur - Fahrplan und Netzdesign, Bern

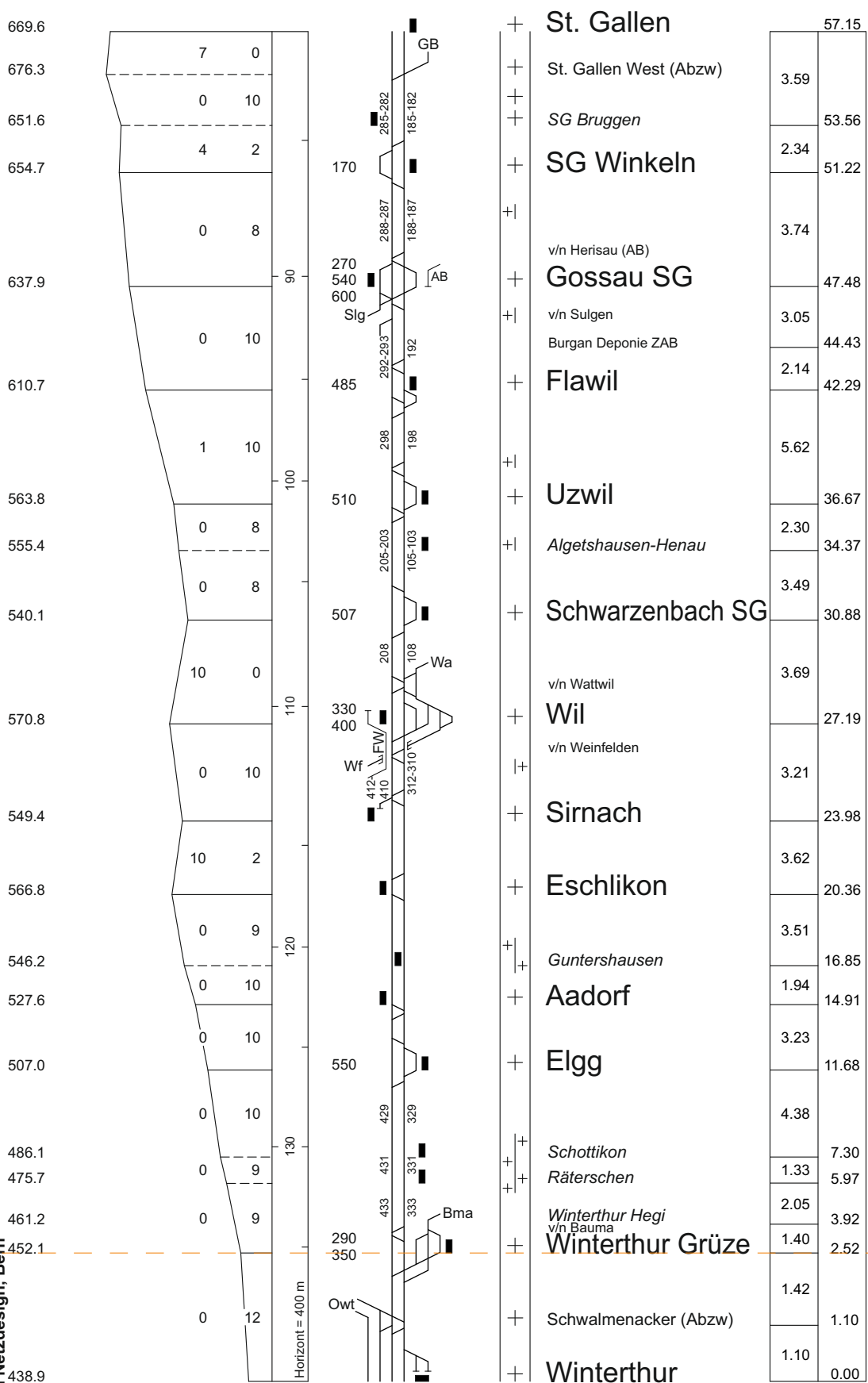



I-FN-FPA-ROT

Ausgabe von 11.12.2016

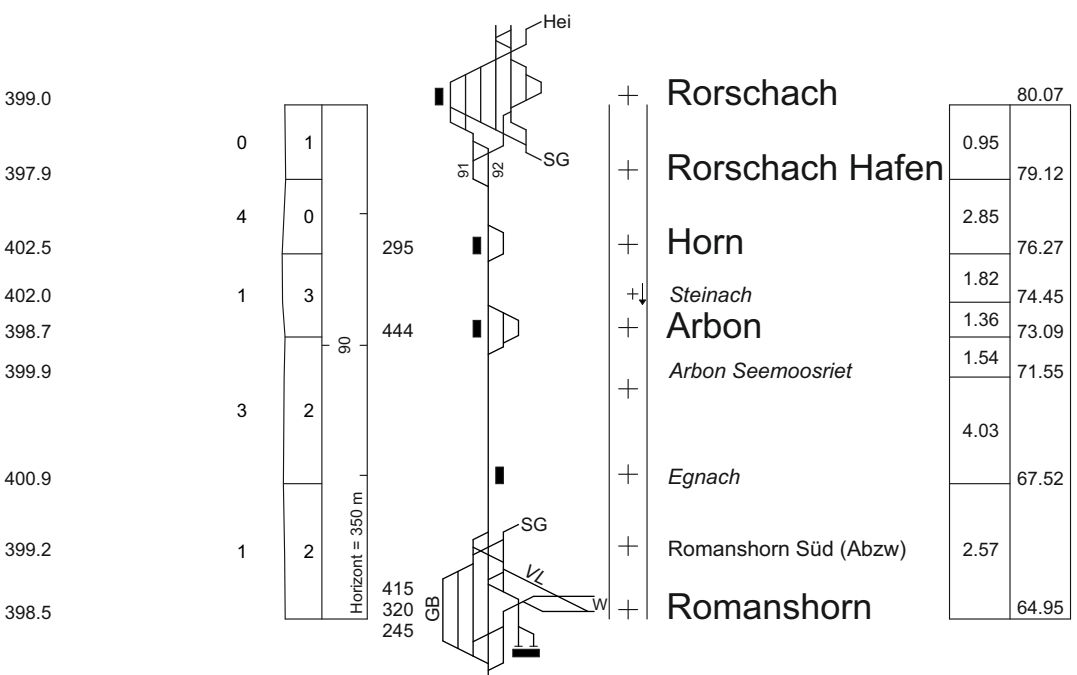
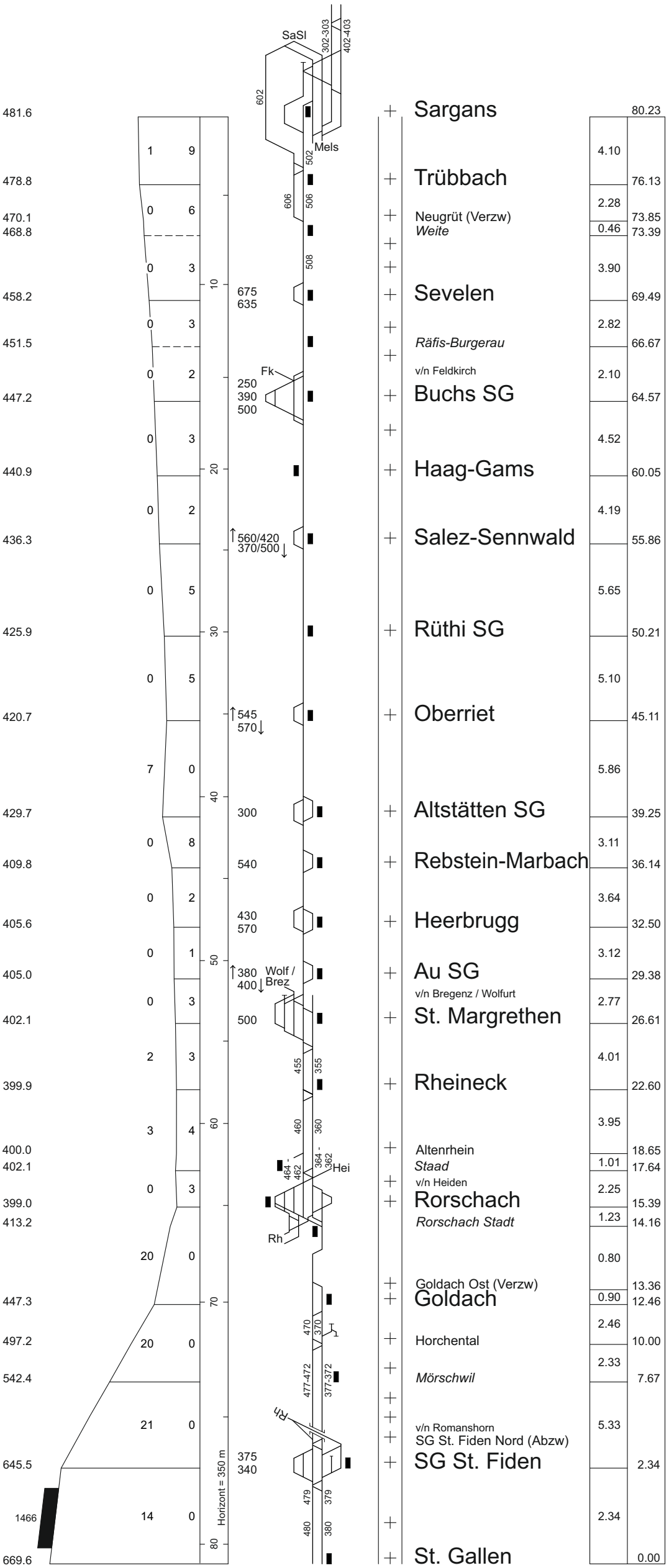
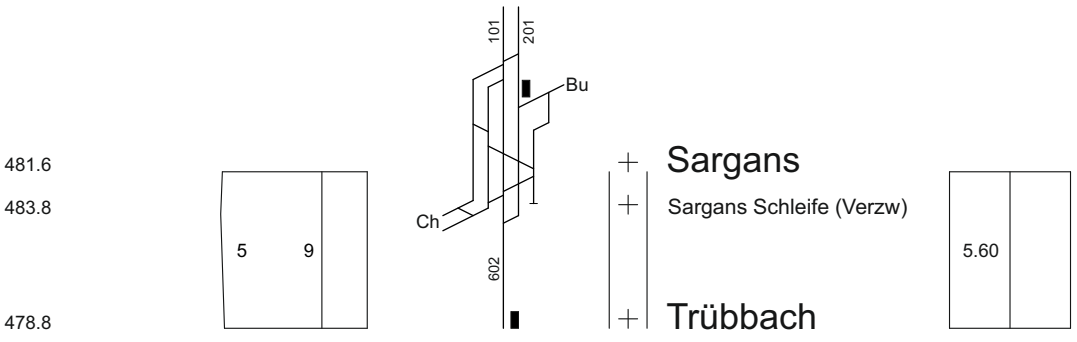



SBB 73

I-FN-FPA-ROT

Ausgabe von 11.12.2016

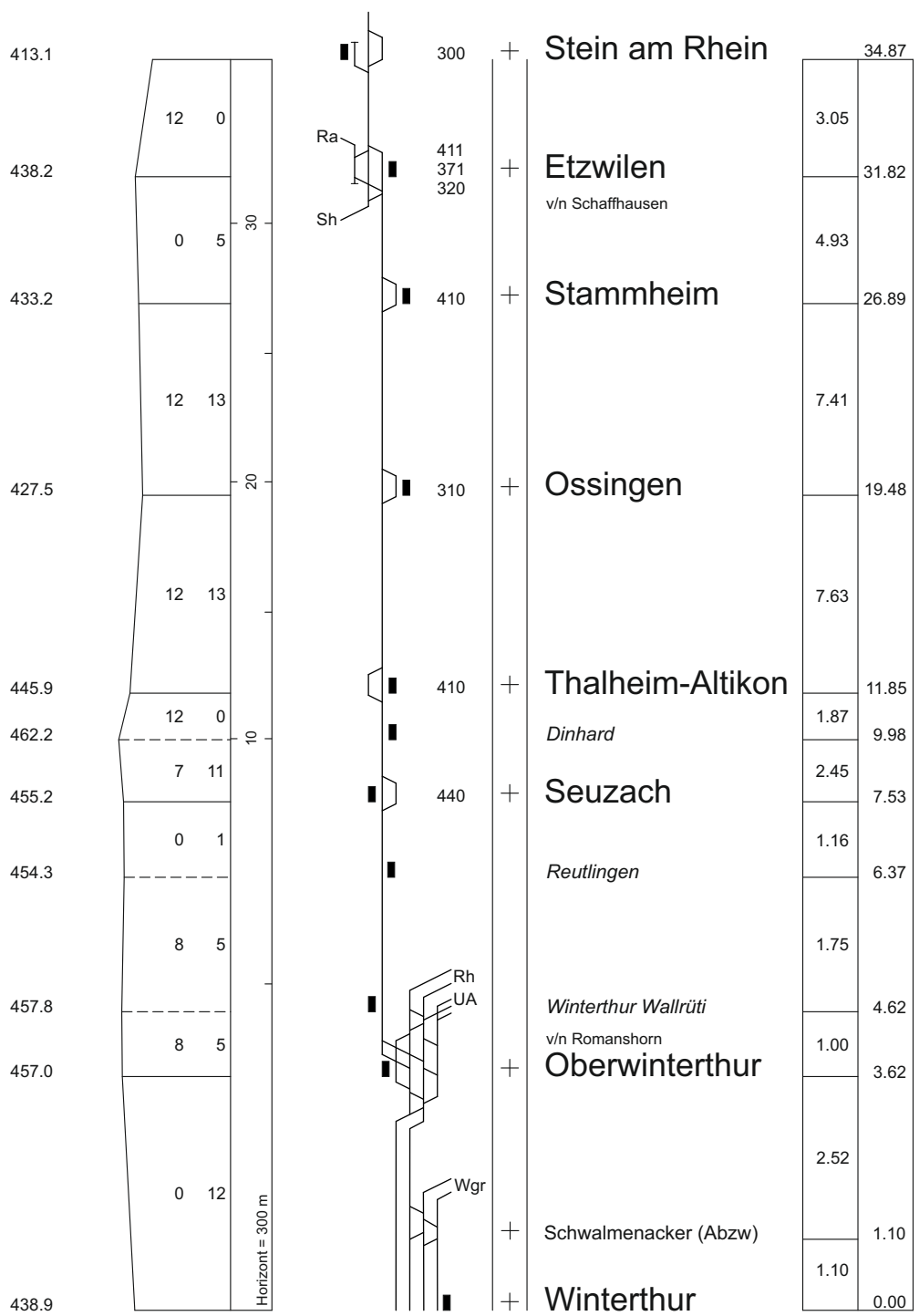

© Infrastruktur - Fahrplan und Netzdesign, Bern

Höhe über Meer
RPN=373.60

Längenprofil
Grösstes Gefälle
Grösste Steigung
Kilometrierung

Stationsanlage
Abzweigungen
Längste Ausweichleise

Blockstationen

Entfernung von Stat. zu Stat.
Entfernung vom Ausgangspunkt

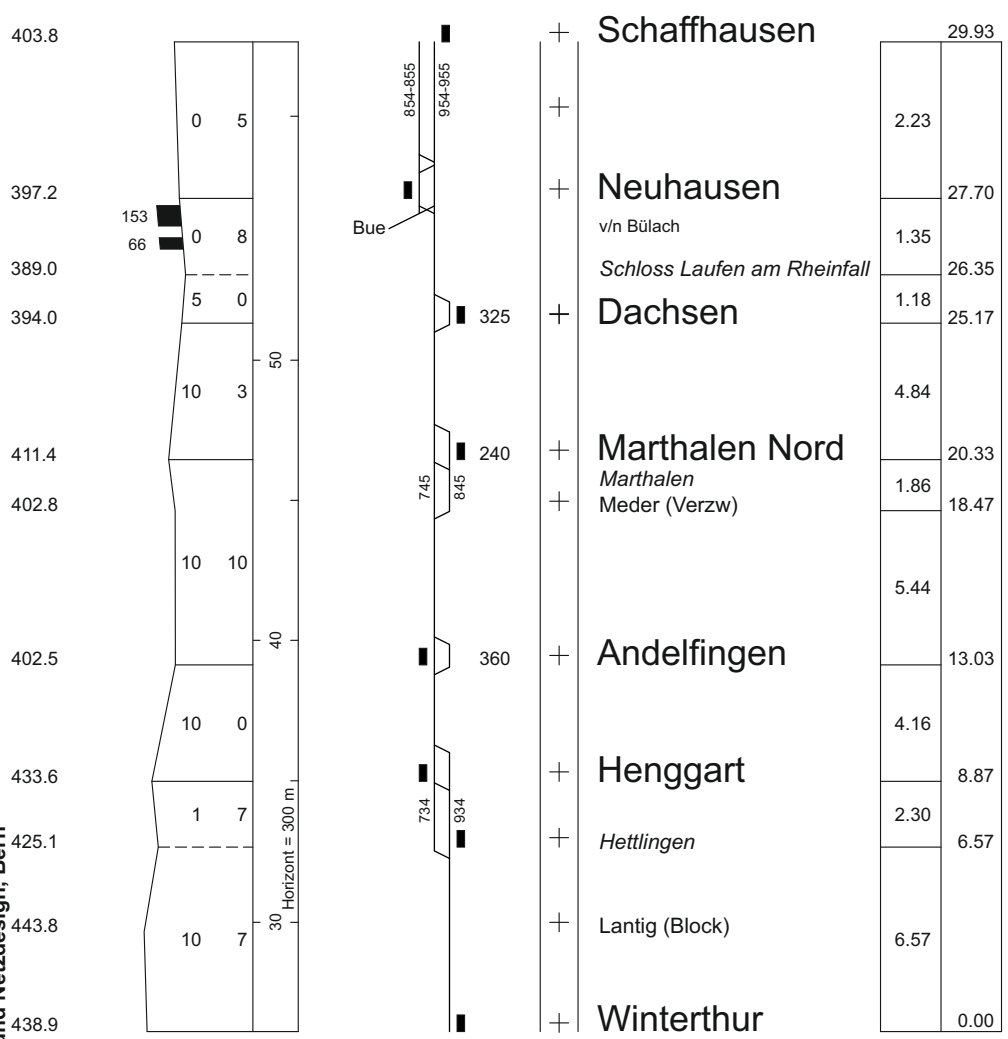



SBB 74

I-FN-FPA-ROT

Ausgabe von 11.12.2016

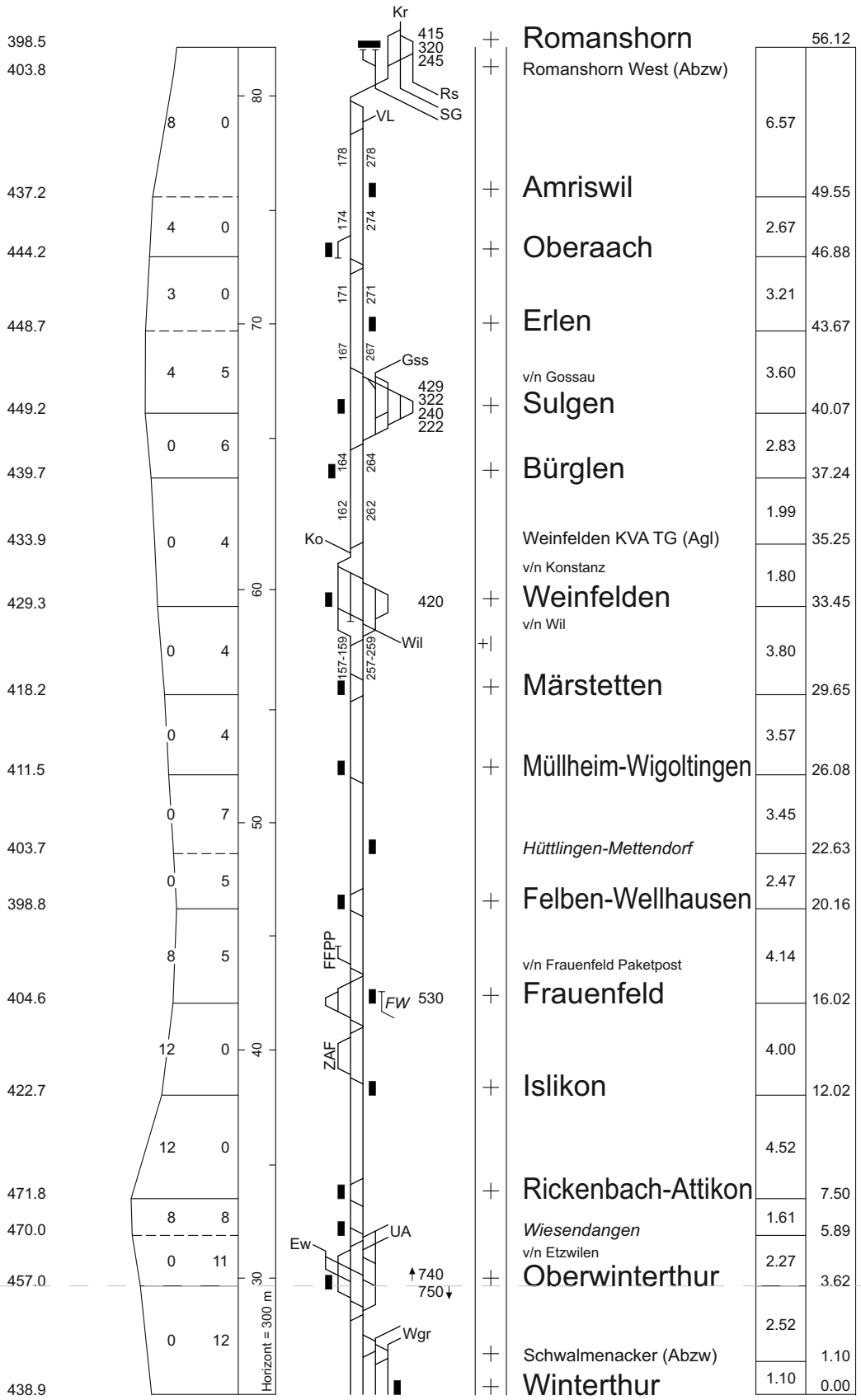
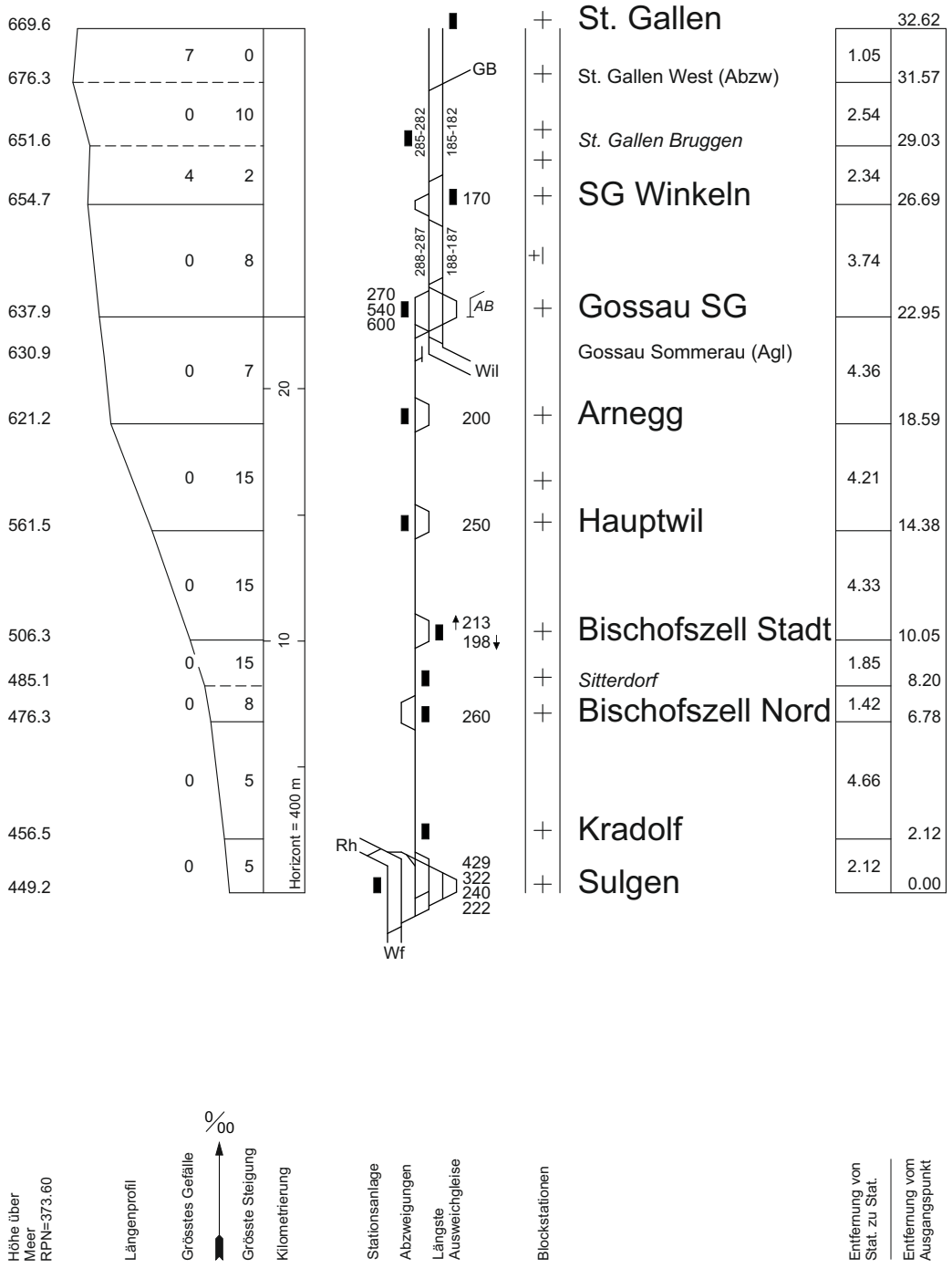

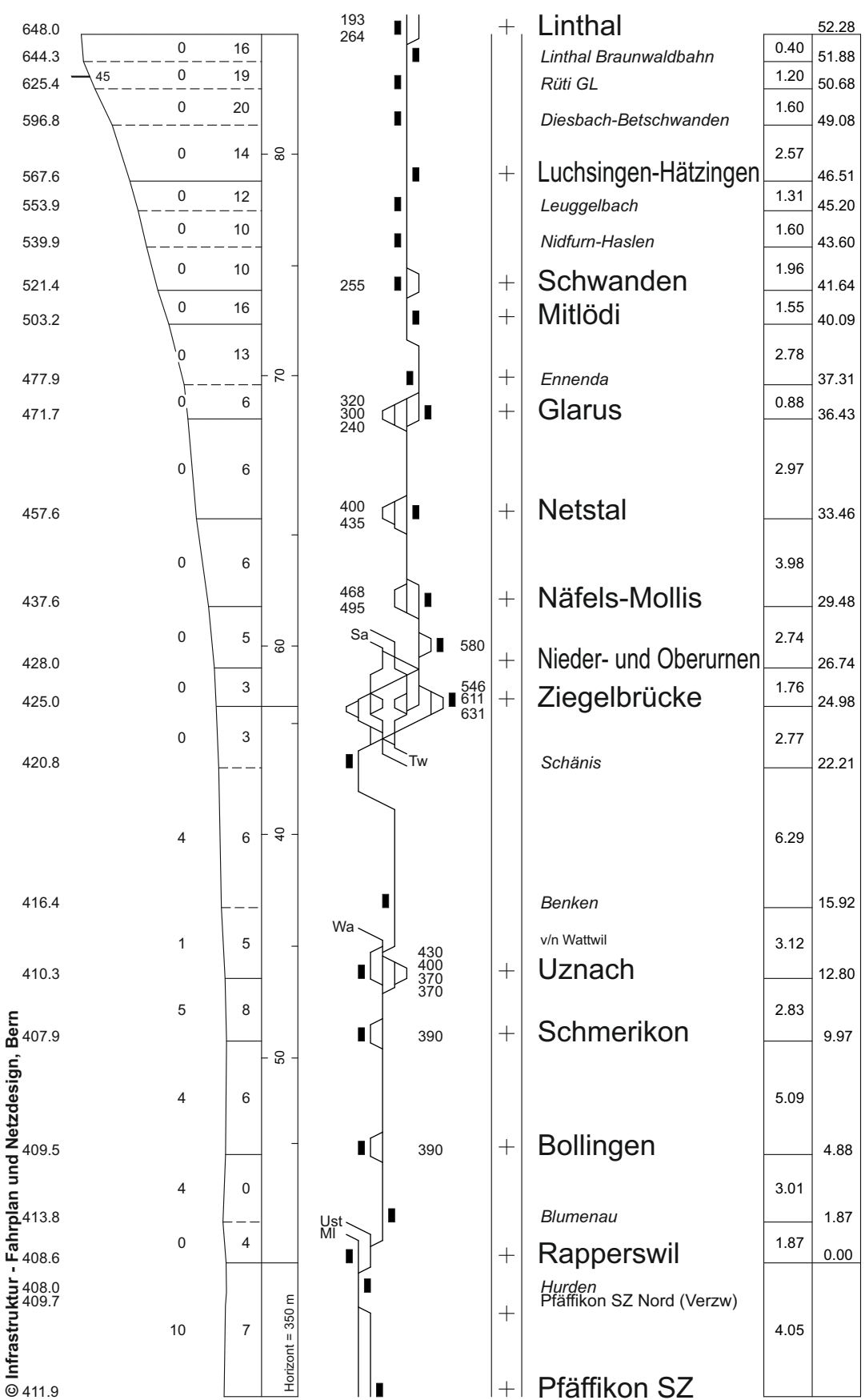
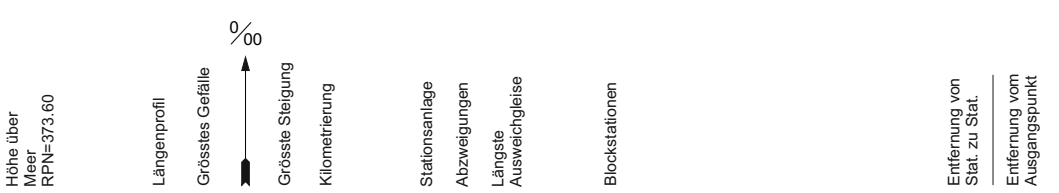
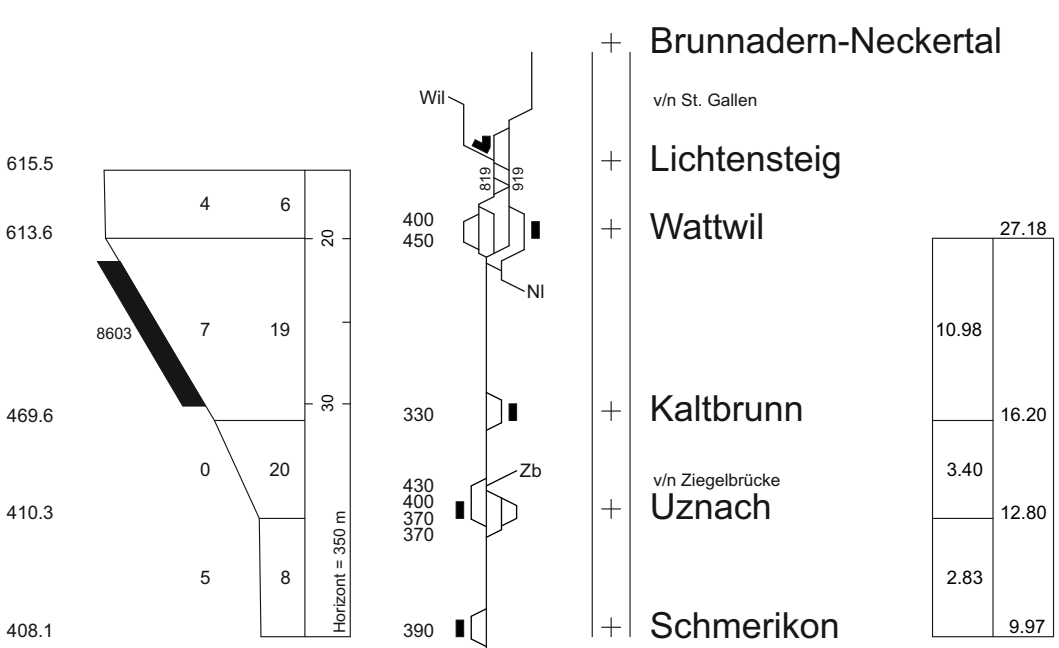
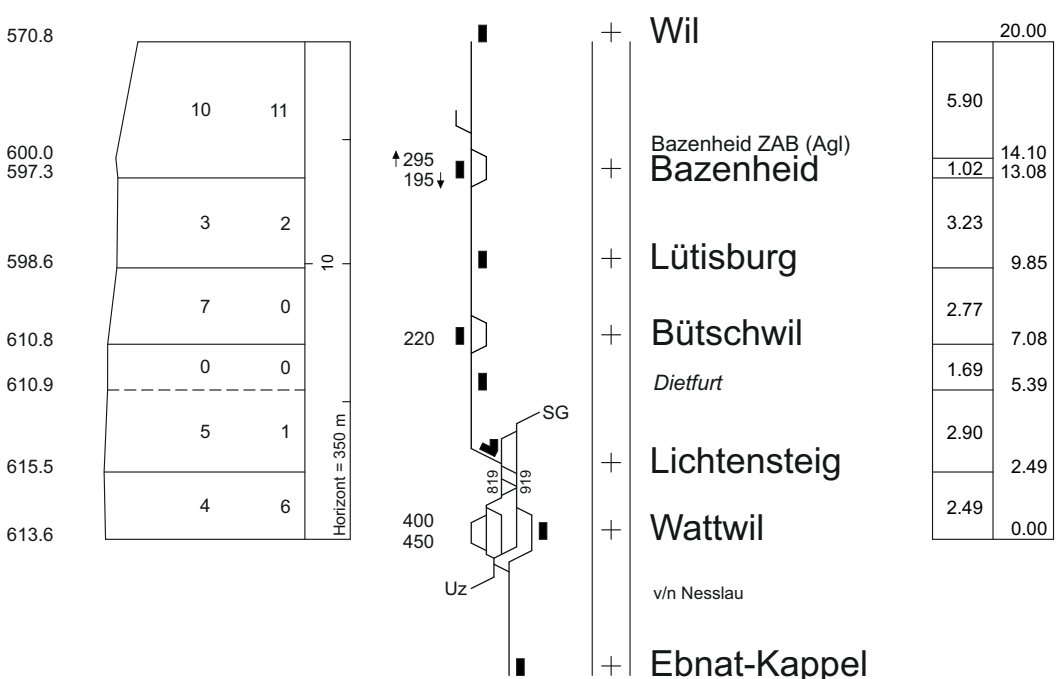



SBB 76

I-FN-FPA-ROT

Ausgabe von 11.12.2016

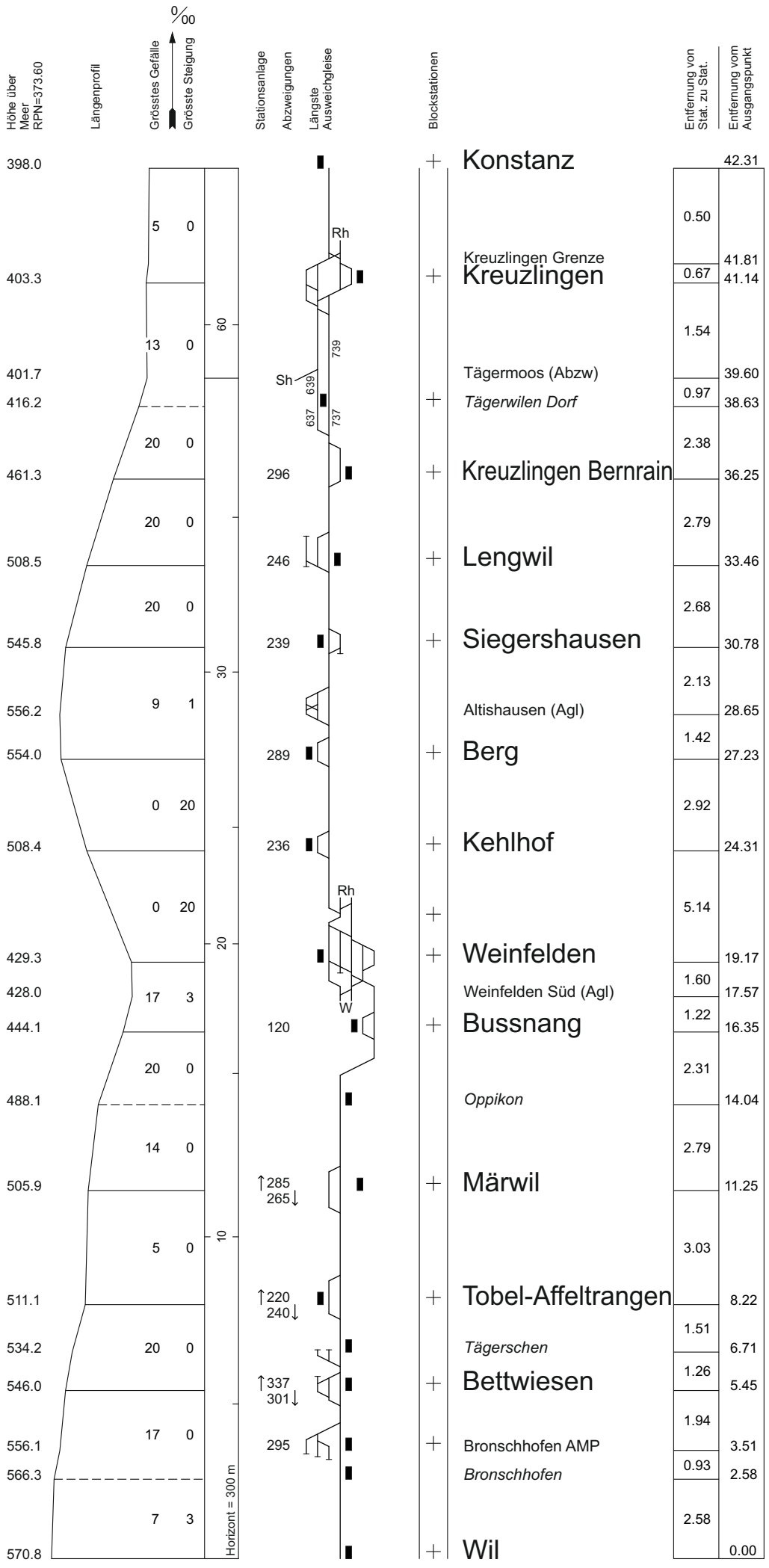



SBB 77

I-FN-FPA-ROT

Ausgabe von 11.12.2016

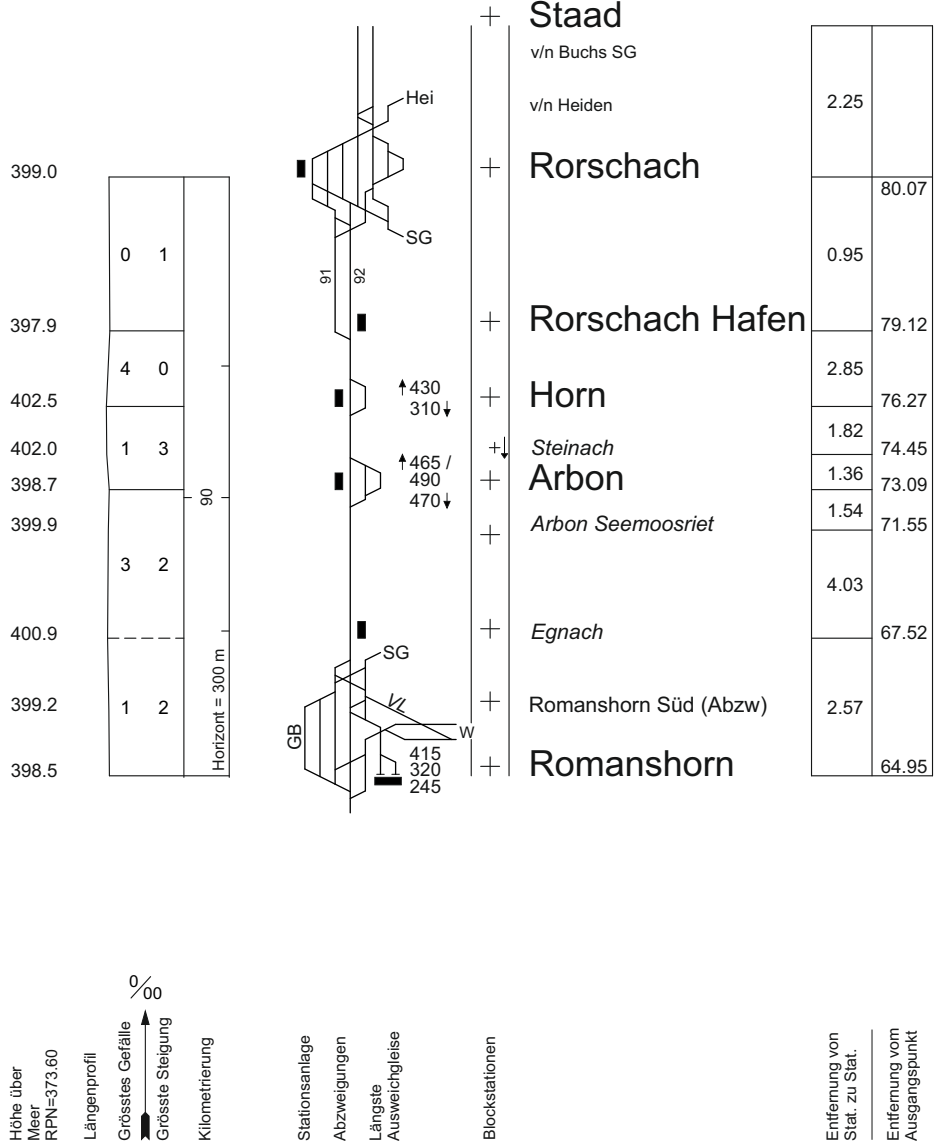

Höhe über Meer
RPN=373.60

Längenprofil

Grossstes Gefälle

Grosste Steigung

Kilometrierung

0/00

Stationsanlage

Abzweigungen

Längste Ausweichleise

Blockstationen

Entfernung von Stat. zu Stat.

Entfernung vom Ausgangspunkt

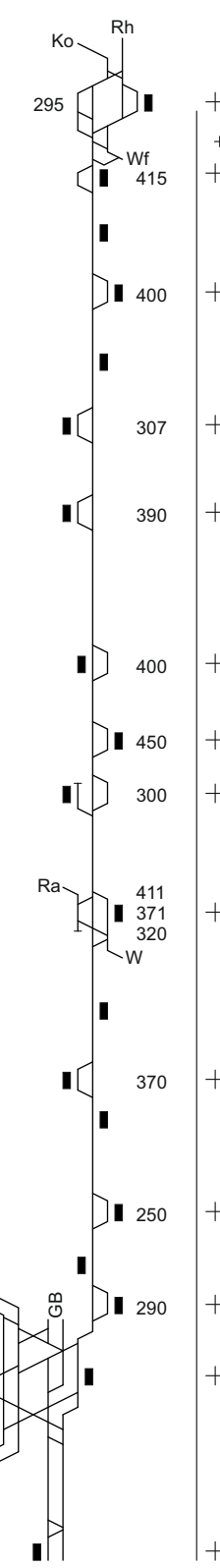
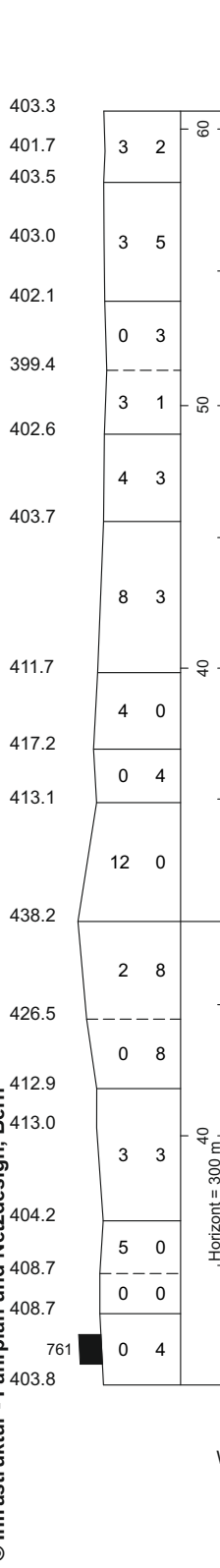
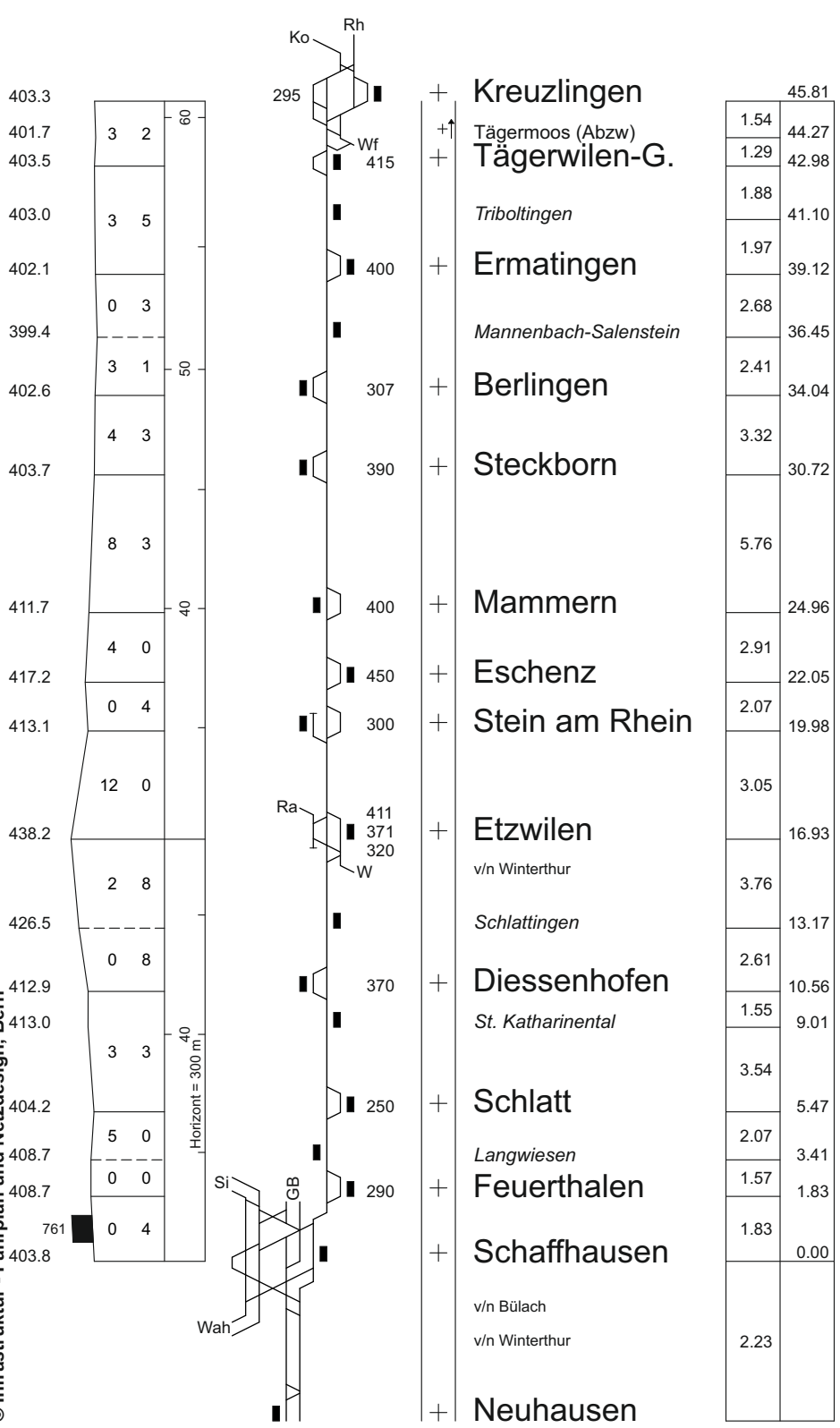
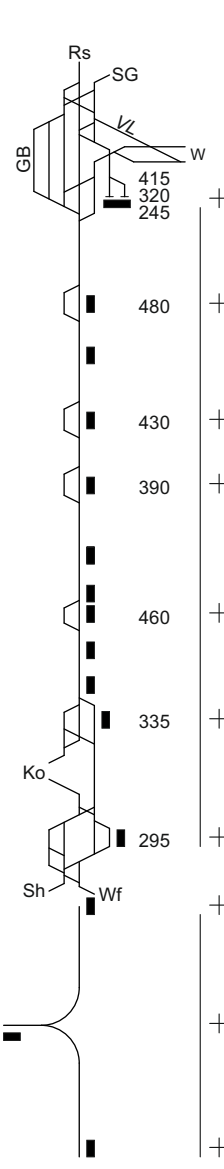
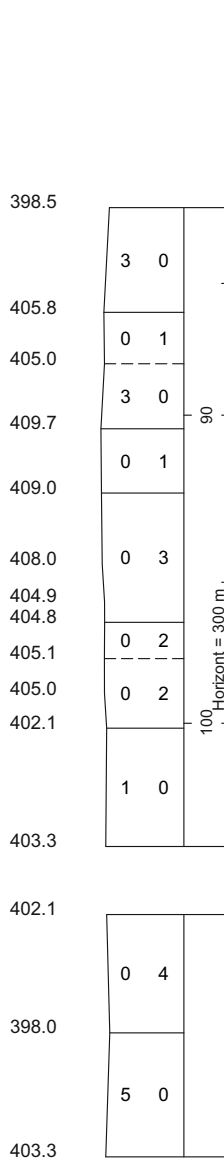
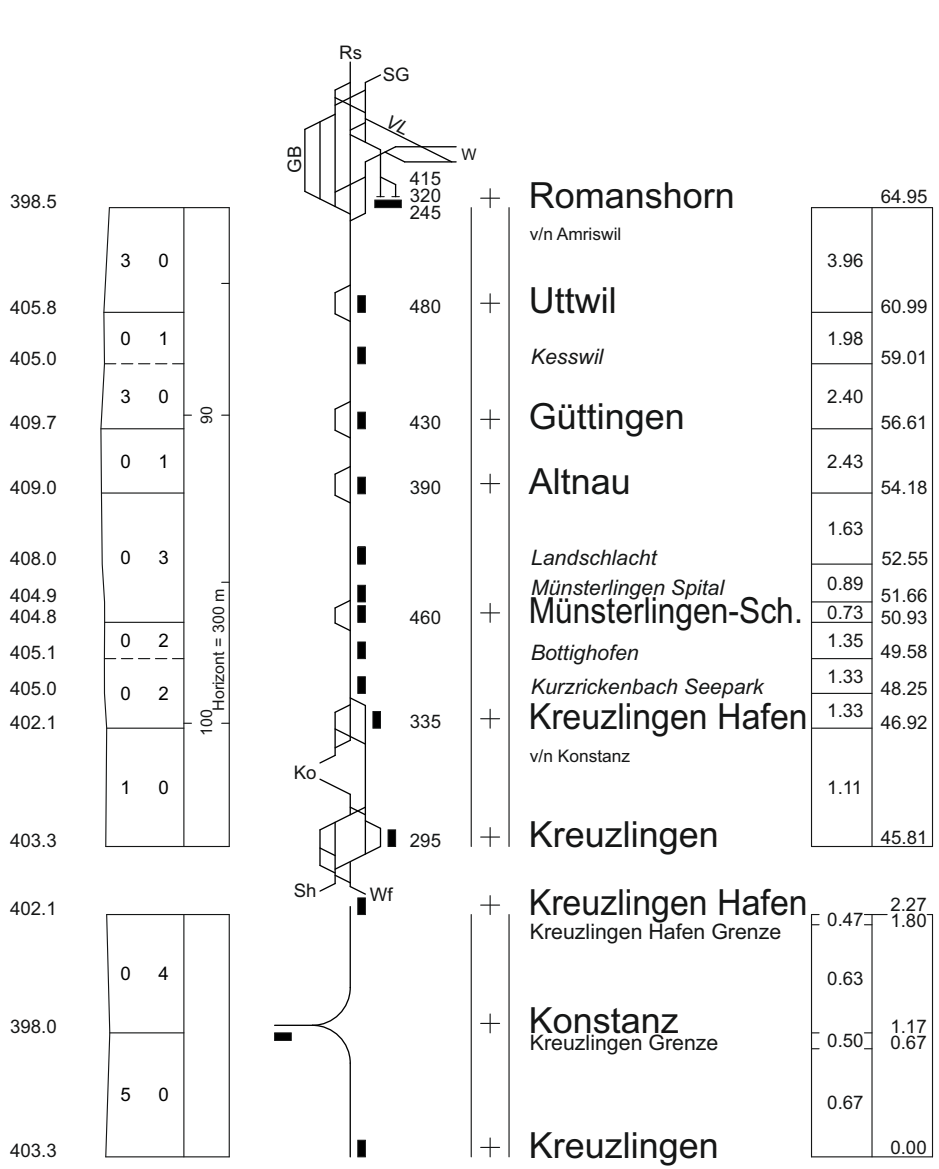

© Infrastruktur - Fahrplan und Netzdesign, Bern

SOB SÜDOSTBAHN

79

11. Dez. 2016 - 09. Dez. 2017

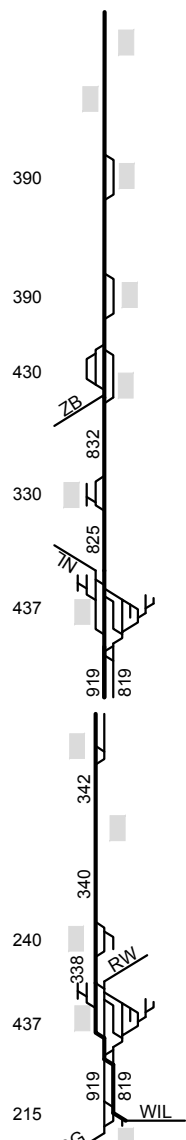
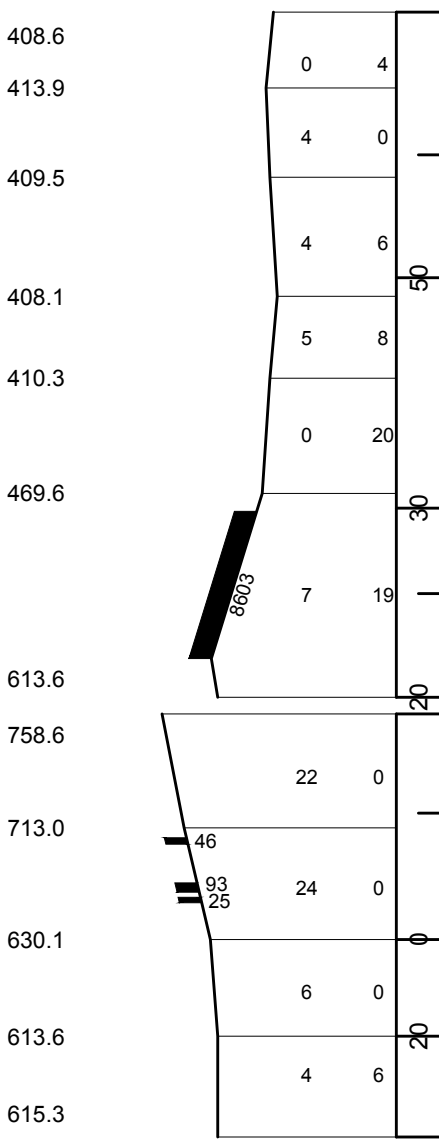

- + Rapperswil
Blumenau (H)
- + Bollingen
- + Schmerikon
- + Uznach
- + Kaltbrunn
- + Wattwil
- + Nesslau
- + Krummenau (H)
- + Ebnat-Kappel
- + Wattwil
Wattwil-Nord
- + Lichtensteig

1.87	0.00	RW
1.87	1.87	BLU
3.01	4.88	BOLI
5.09	9.97	SCME
2.83	12.80	UZ
3.40	16.20	KAB
10.98	27.18	WA
3.59	7.85	NL
4.26	4.26	KRU
4.26	0.00 24.86	EK
4.86	20.00 53.16	WA WAND
2.49	50.67	LSG

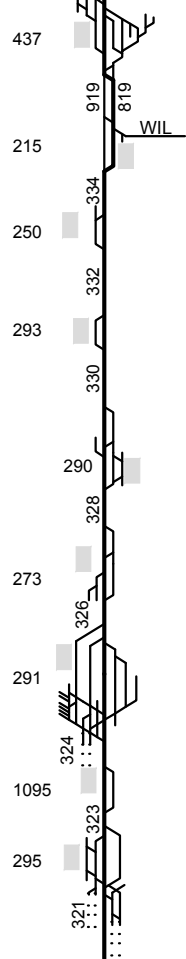
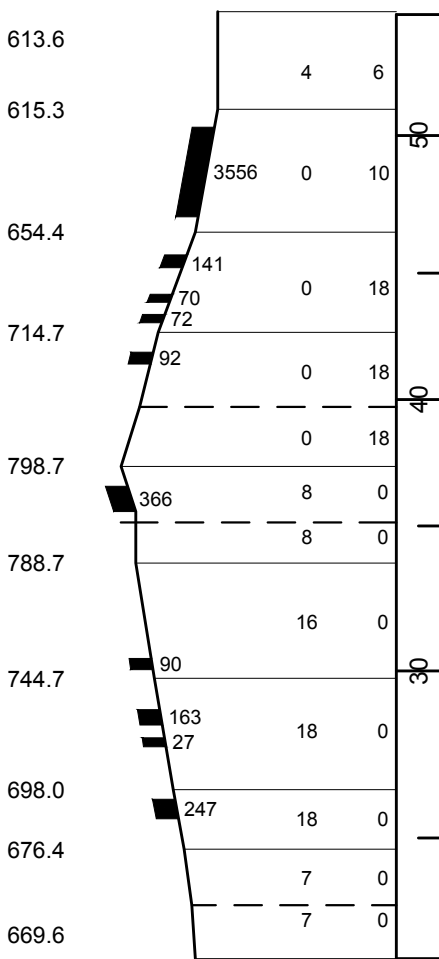

- + Wattwil
Wattwil-Nord
- + Lichtensteig
- + Brunnadern-Neckertal
- + Mogelsberg
- + Degersheim West
- + Degersheim
- + Schachen West
Schachen (Herisau)
- + Herisau
- + Günsensee
- + St.Gallen Haggen
- + St.Gallen West
- + St. Gallen

2.49	53.16	WA WAND
4.27	50.67	LSG
4.27	46.40	BRN
3.98	42.42	MOG
2.92	39.50	DGWE
2.40	37.10	DG
3.71	33.39	SCW SCH
3.66	29.73	HE
3.28	26.45	GUEB
2.04	24.41	SGHA
2.95	21.46	SGW SG

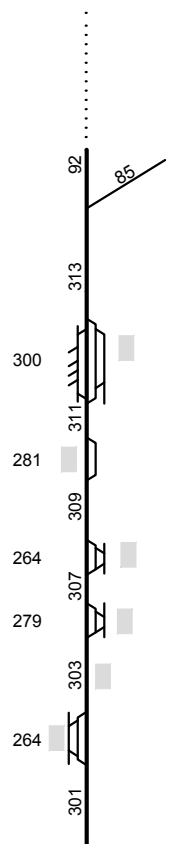
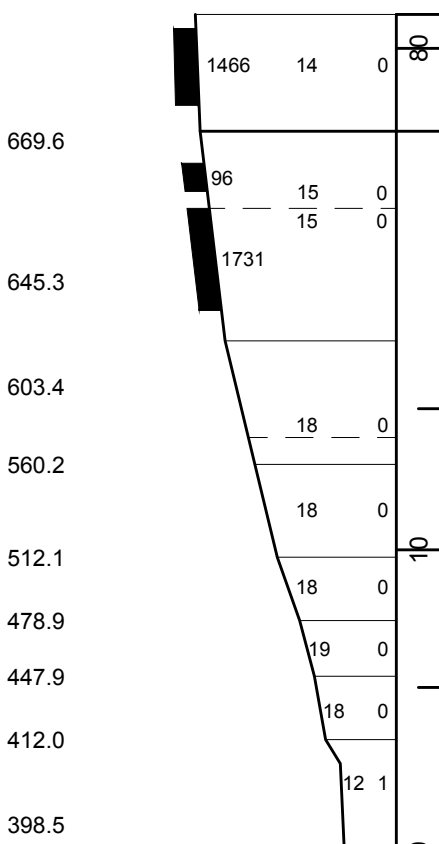

- + St. Gallen
- + St.Gallen St.Fiden
St.Gallen St.Fiden Nord
- + Bruggwald
- + Wittenbach
- + Roggwil-Berg Süd
Roggwil-Berg
- + Häggenschwil-Winden
- + Muolen
- + Steinebrunn (H)
- + Neukirch-Egnach
- + Romanshorn Süd
- + Romanshorn

2.33	21.46	SG
19.13	19.13	SGF SGFN
3.51	15.62	BRWA
2.78	12.84	WIT
3.27	9.57	ROBS ROBG
2.28	7.29	HAEW
1.98	5.31	MUO
2.28	3.03	STB
3.03	0.00	NK RHS RH

Höhen über Meer
RPN=373.60
Meter

Längenprofil

Grösstes Gefälle
‰

Grösste Steigung
Kilometrierung

Stationslage,
Abzweigungen,
Längste Aus-
weichelse

Blockstationen

Entfernung zwischen
den Betriebspunkten
km

Entfernung vom
Ausgangspunkt

SOB SÜDOSTBAHN

79

11. Dez. 2016 - 09. Dez. 2017

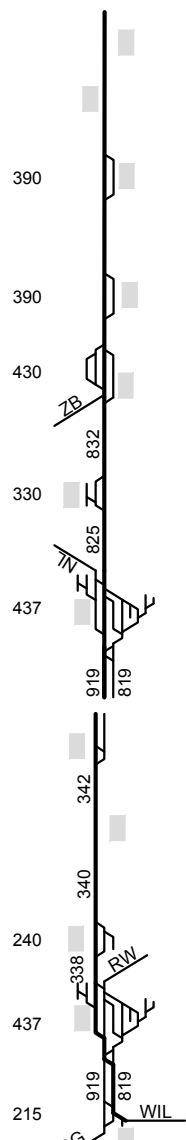
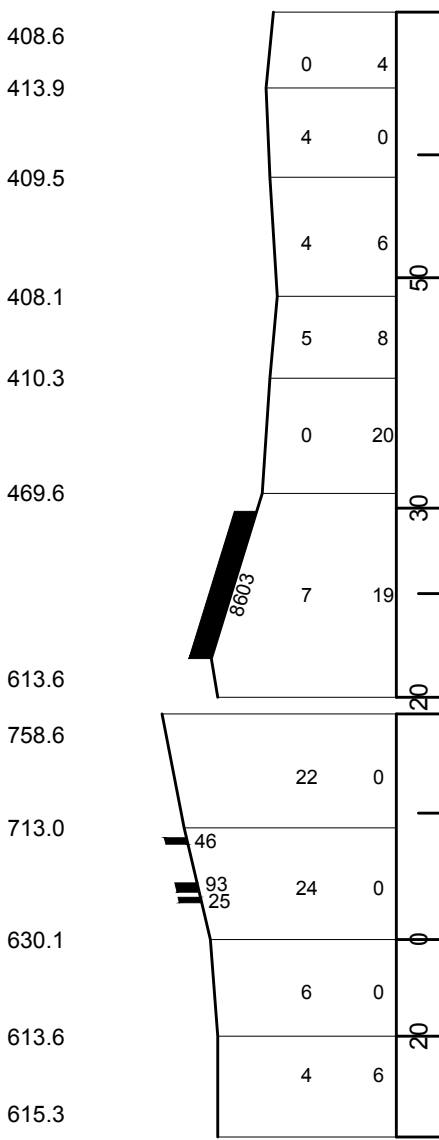

- + Rapperswil
Blumenau (H)
- + Bollingen
- + Schmerikon
- + Uznach
- + Kaltbrunn
- + Wattwil
- + Nesslau
- + Krummenau (H)
- + Ebnat-Kappel
- + Wattwil
Wattwil-Nord
- + Lichtensteig

1.87	0.00	RW
1.87	1.87	BLU
3.01	4.88	BOLI
5.09	9.97	SCME
2.83	12.80	UZ
3.40	16.20	KAB
10.98	27.18	WA
3.59	7.85	NL
4.26	4.26	KRU
4.26	0.00 24.86	EK
4.86	20.00 53.16	WA WAND
2.49	50.67	LSG

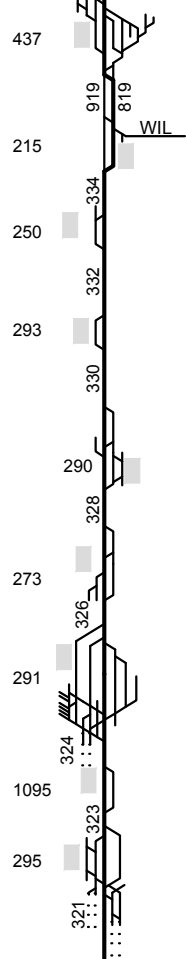
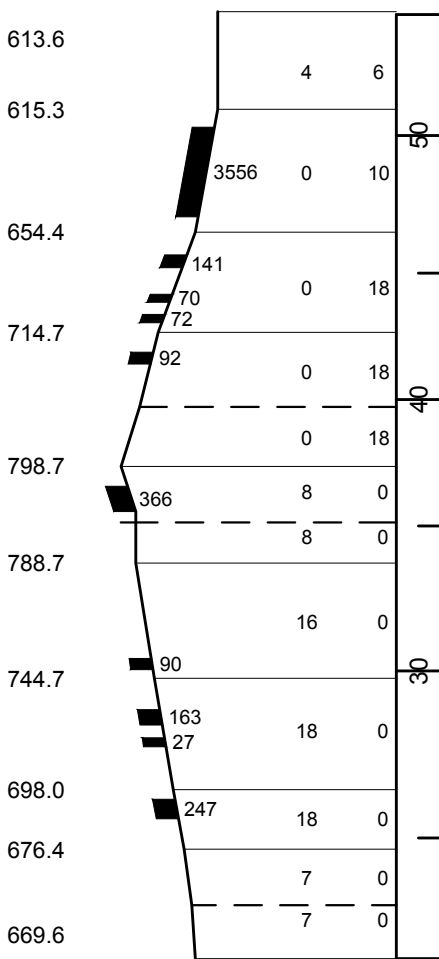

- + Wattwil
Wattwil-Nord
- + Lichtensteig
- + Brunnadern-Neckertal
- + Mogelsberg
- + Degersheim West
- + Degersheim
- + Schachen West
Schachen (Herisau)
- + Herisau
- + Günsensee
- + St.Gallen Haggen
- + St.Gallen West
- + St. Gallen

2.49	53.16	WA WAND
4.27	50.67	LSG
4.27	46.40	BRN
3.98	42.42	MOG
2.92	39.50	DGWE
2.40	37.10	DG
3.71	33.39	SCW SCH
3.66	29.73	HE
3.28	26.45	GUEB
2.04	24.41	SGHA
2.95	21.46	SGW SG

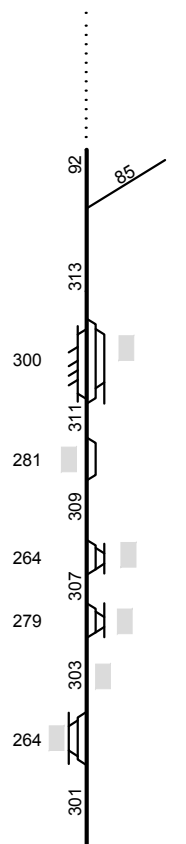
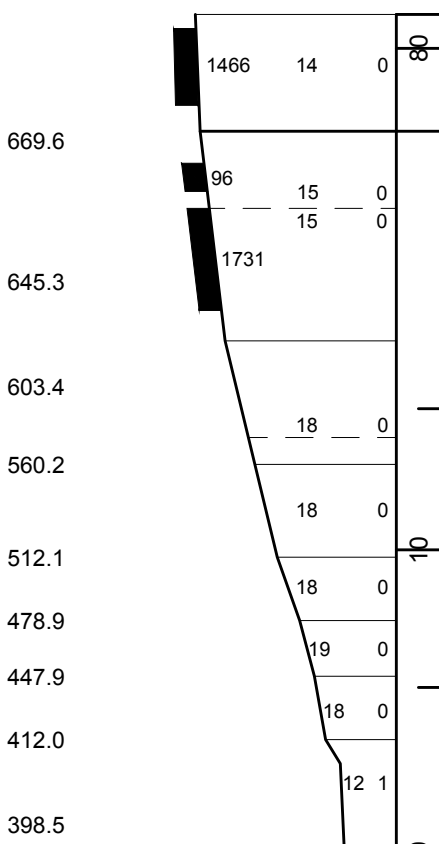

- + St. Gallen
- + St.Gallen St.Fiden
- + St.Gallen St.Fiden Nord
- + Bruggwald
- + Wittenbach
- + Roggwil-Berg Süd
- + Roggwil-Berg
- + Häggenschwil-Winden
- + Muolen
- + Steinebrunn (H)
- + Neukirch-Egnach
- + Romanshorn Süd
- + Romanshorn

2.33	21.46	SG
3.51	19.13	SGF SGFN
3.51	15.62	BRWA
2.78	12.84	WIT
3.27	9.57	ROBS ROBG
2.28	7.29	HAEW
1.98	5.31	MUO
2.28	3.03	STB
3.03	0.00	NK RHS RH

Höhen über Meer
RPN=373.60
Meter

Längenprofil

Grösstes Gefälle
‰

Grösste Steigung
Kilometrierung

Stationslage,
Abzweigungen,
Längste Aus-
weichelse

Blockstationen

Entfernung zwischen
den Betriebspunkten
km

Entfernung vom
Ausgangspunkt