

Fahrpläne Basel Ost ab 05.02.2018

Stunden: 0 - 12

Niederlassung Südwest

Jahresfahrplan 2018 vom: 10. Dezember 2017 bis: 08. Dezember 2018
Gültig vom: 05. Februar 2018 bis: 08. April 2018 / täglich

Fahrpläne Basel Ost ab 05.02.2018

Stunden: 0 - 12

Basel Bad Bf - Riehen	
P2B	
Hauptbahn	
120	
4000	
2.6	0.8
2.2	3.0
1.3	4.3

Basel Bad Bf - Grenzach	
GNT und P2B	
Hauptbahn	
130 >160 <	
4000	
2.5	2.4
273.2	
275.6	

Basel Bad Bf - Riehen	
P2B	
Hauptbahn	
120	
4000	
2.6	0.8
2.2	3.0
1.3	4.3

Basel Bad Bf - Grenzach	
GNT und P2B	
Hauptbahn	
130 >160 <	
4000	
2.5	2.4
273.2	
275.6	

Basel Bad Bf - Riehen	
P2B	
Hauptbahn	
120	
4000	
2.6	0.8
2.2	3.0
1.3	4.3

Basel Bad Bf - Grenzach	
GNT und P2B	
Hauptbahn	
130 >160 <	
4000	
2.5	2.4
273.2	
275.6	

BAV 525
Riehen Niederholz Hp
Riehen
Riehen LGR

BAV 521 / 2
Basel Bad Bf LGR
Sbk 9093 / Sbk 9092
Grenzach

BAV 525
Riehen Niederholz Hp
Riehen
Riehen LGR

BAV 521 / 2
Basel Bad Bf LGR
Sbk 9093 / Sbk 9092
Grenzach

BAV 525
Riehen Niederholz Hp
Riehen
Riehen LGR

BAV 521 / 2
Basel Bad Bf LGR
Sbk 9093 / Sbk 9092
Grenzach

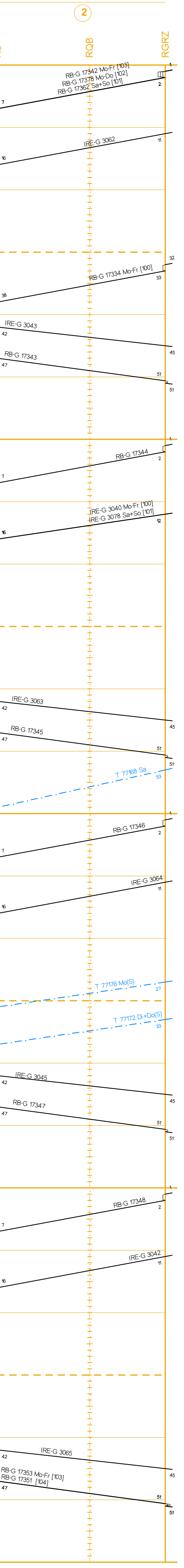
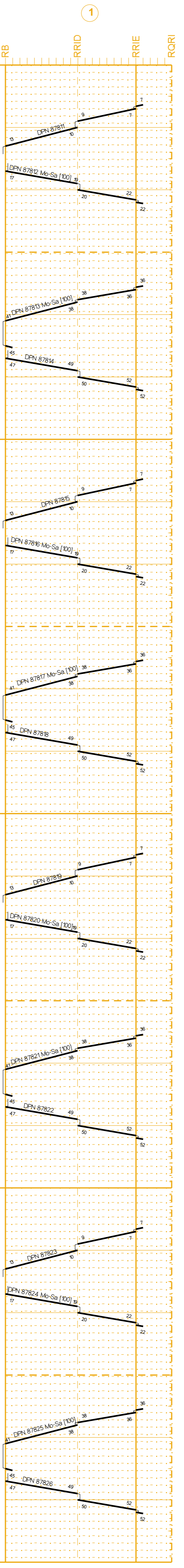
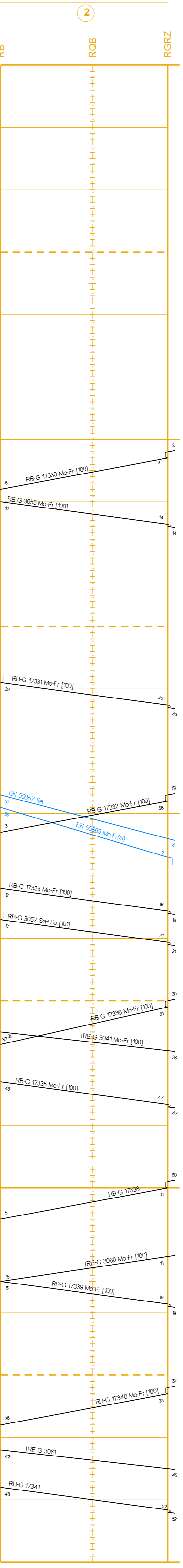
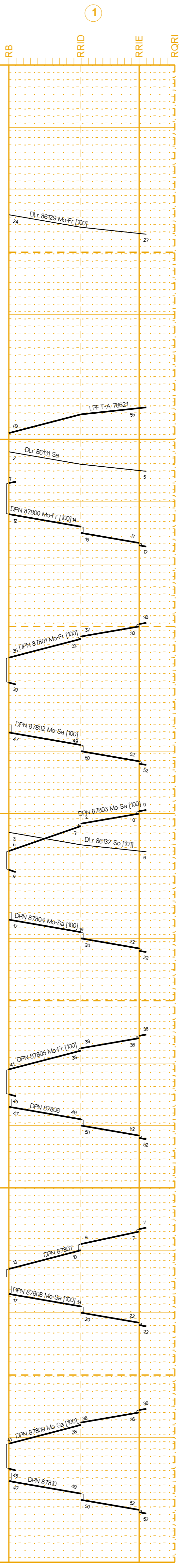
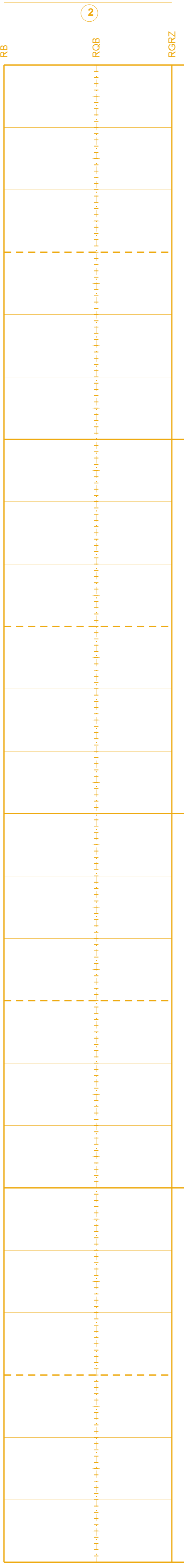
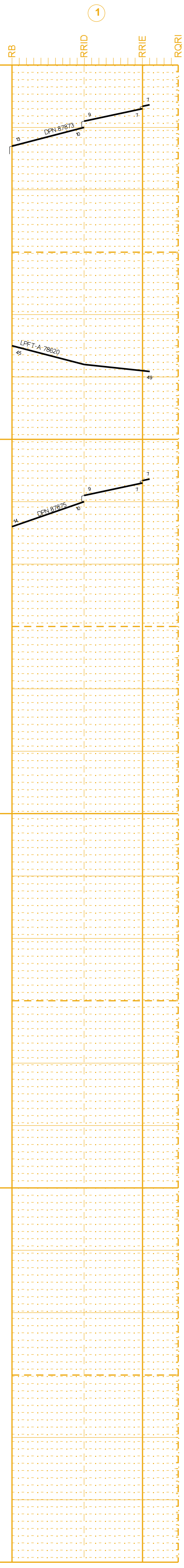

[100] nicht: 30.3.18, 2.4.18
auch: 30.3.18, 2.4.18
[101] 26.3.18 - 6.4.18 Mo-Do
nicht: 2.4.18
auch: 6.4.18
[102] 5.2.18 - 23.3.18 Mo-Fr
5.2.18 - 25.3.18 Sa+So
26.3.18 - 8.4.18
[103] nicht: 2.4.18
auch: 6.4.18
[104] 5.2.18 - 23.3.18 Mo-Fr
5.2.18 - 25.3.18 Sa+So
26.3.18 - 8.4.18

